

BEARINGS FOR INDUSTRIAL MACHINERY
NSKHPS – HIGH PERFORMANCE STANDARD



As one of the world's leading manufacturers of rolling bearings, linear technology components and steering systems, we can be found on almost every continent – with production facilities, sales offices and technology centres – because our customers appreciate short decision-making channels, prompt deliveries and local service.



The NSK company

NSK commenced operations as the first Japanese manufacturer of rolling bearings back in 1916. Ever since, we have been continuously expanding and improving not only our product portfolio but also our range of services for various industrial sectors. In this context, we develop technologies in the fields of rolling bearings, linear systems, components for the automotive industry and mechatronic systems. Our research and production facilities in Europe, Americas and Asia are linked together in a global technology

network. Here we concentrate not only on the development of new technologies, but also on the continuous optimisation of quality – at every process stage.

Among other things, our research activities include product design, simulation applications using a variety of analytical systems and the development of different steels and lubricants for rolling bearings.

Partnership based on trust – and trust based on quality

Total Quality by NSK: The synergies of our global network of NSK Technology Centres. Just one example of how we meet our requirements for high quality.

NSK is one of the leading companies with a long tradition in patent applications for machine parts. In our worldwide research centres, we not only concentrate on the development of new technologies, but also on the continual improvement of quality based on the integrated technology

platform of tribology, material technology, analysis and mechatronics.

More about NSK at www.nsk europe.com or call us on + 44 (0) 1636 605 123



Content

Angular Contact Ball Bearings	6
Angular Contact Ball Bearings – High Precision	8
Ball Screw Support Angular Contact Thrust Ball Bearings	14
Cylindrical Roller Bearings	16
Deep Groove Ball Bearings	18
Spherical Roller Bearings	20

NSKHPS – Redefining the standard

Continually developing products with greater strength and higher accuracy, NSK's new NSKHPS fully incorporate the advantages of NSK's worldclass design, materials, and manufacturing technology, setting a new standard for bearings.

**Long
Life**

**High
Accuracy**

**Higher
Limiting
Speed**

**Universal
Matching**

**Wide
Range
Lineup**

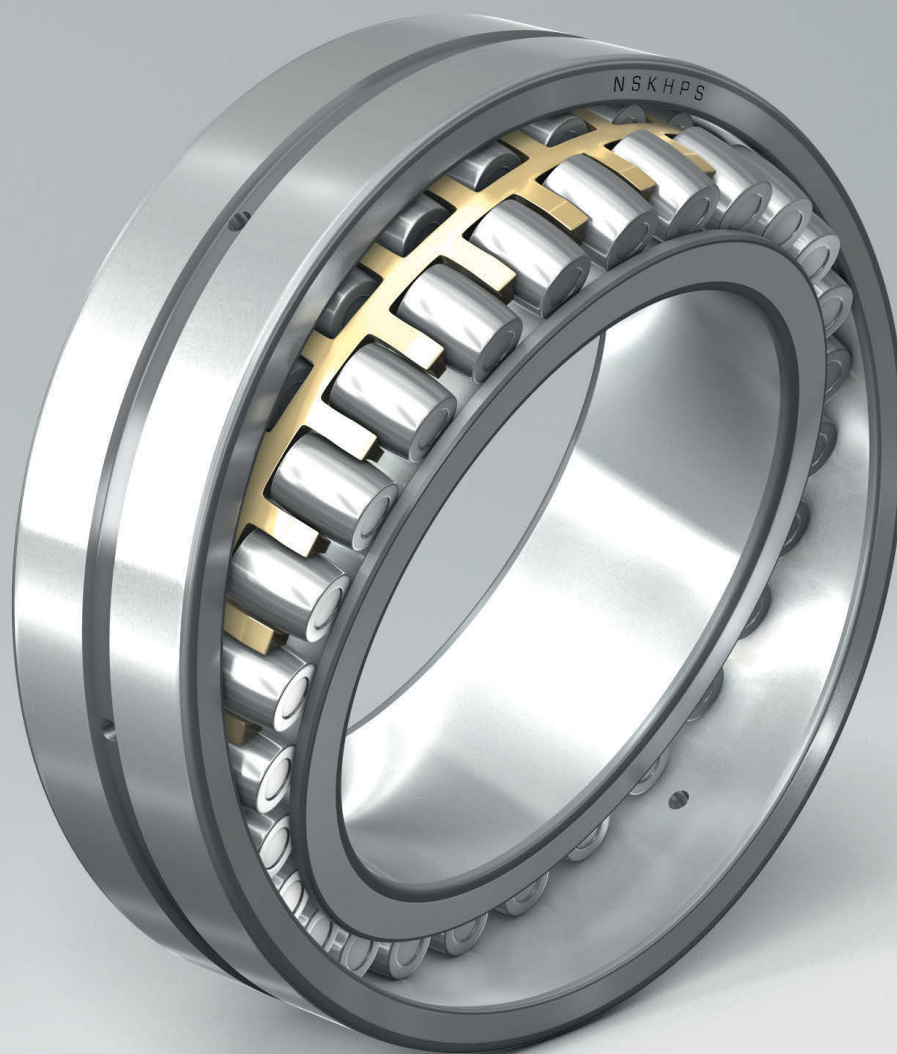

Angular Contact Ball Bearings

Features compared with conventional bearings

- › Bearing life 90% higher (maximum)
- › Limiting Speed 20% higher (maximum)
- › High Accuracy/Running Accuracy ISO class 5/
Dimensional Accuracy ISO class 6
- › Universal Matching/Wide range combination
is possible



Nomenclature

Example:

72 08 B EA MR SU CNB

Bearing Series

72, 73: Single-Row Angular Contact
Ball Bearings

Bore

Bore number indicates bore diameter.
01:12mm; 02:15mm; 03:17mm
04 or Larger: Bore Number × 5 (mm)

Contact Angle

B: Standard Contact Angle of 40°

Internal Design

EA: High Load Capacity

Preload

CNB, GA

Arrangement

SU: Universal Matching

Cage

MR: Machined Brass Cage
T85: Polyamide 46 Resin Cage
T7: L-PPS Resin Cage

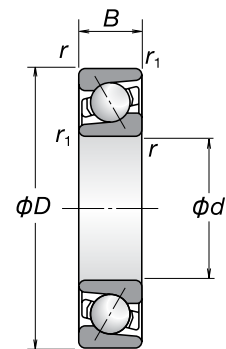

Matched Measured Axial Clearance

Bore Diameter		CNB		GA	
Over	Incl.	Min.	Max.	Min.	Max.
mm		µm		µm	
12	18	17	25	-2	6
18	30	20	28	-2	6
30	50	24	32	-2	6
50	80	29	41	-3	9

Boundary Dimensions (mm)					Basic Load Ratings (N)		Limiting Speed (rpm)		Bearing Numbers
d	D	B	r (min.)	r ₁ (min.)	C _r	C _{0r}	Grease	Oil	
12	32	10	0.6	0.3	8,150	3,750	20,000	30,000	7201BEA
	37	12	1.0	0.6	11,100	4,950	18,000	26,000	7301BEA
15	35	11	0.6	0.3	9,800	4,800	18,000	26,000	7202BEA
	42	13	1.0	0.6	14,300	6,900	16,000	22,000	7302BEA
17	40	12	0.6	0.3	11,600	6,100	16,000	22,000	7203BEA
	47	14	1.0	0.6	16,800	8,300	14,000	20,000	7303BEA
20	47	14	1.0	0.6	15,600	8,150	13,000	19,000	7204BEA
	52	15	1.1	0.6	19,800	10,500	13,000	18,000	7304BEA
25	52	15	1.0	0.6	17,600	10,200	12,000	17,000	7205BEA
	62	17	1.1	0.6	27,200	14,900	10,000	15,000	7305BEA
30	62	16	1.0	0.6	23,700	14,300	10,000	14,000	7206BEA
	72	19	1.1	0.6	36,500	20,600	9,000	13,000	7306BEA
35	72	17	1.1	0.6	32,500	19,600	8,500	12,000	7207BEA
	80	21	1.5	1.0	40,500	24,400	8,000	11,000	7307BEA
40	80	18	1.1	0.6	38,500	24,500	7,500	11,000	7208BEA
	90	23	1.5	1.0	53,000	33,000	7,100	10,000	7308BEA
45	85	19	1.1	0.6	40,500	27,100	7,100	10,000	7209BEA
	100	25	1.5	1.0	62,500	39,500	6,300	9,000	7309BEA
50	90	20	1.1	0.6	42,000	29,700	6,300	9,500	7210BEA
	110	27	2.0	1.0	78,000	50,500	5,600	8,000	7310BEA
55	100	21	1.5	1.0	51,500	37,000	6,000	8,500	7211BEA
	120	29	2.0	1.0	89,000	58,500	5,000	7,500	7311BEA
60	110	22	1.5	1.0	61,500	45,000	5,300	7,500	7212BEA
	130	31	2.1	1.1	102,000	68,500	4,800	6,700	7312BEA
65	120	23	1.5	1.0	70,000	53,500	4,800	7,100	7213BEA
	140	33	2.1	1.1	114,000	77,000	4,300	6,300	7313BEA
70	125	24	1.5	1.0	75,500	58,500	4,500	6,700	7214BEA
	150	35	2.1	1.1	124,000	87,500	4,000	6,000	7314BEA
75	130	25	1.5	1.0	78,500	63,500	4,300	6,300	7215BEA
	160	37	2.1	1.1	134,000	98,500	3,800	5,600	7315BEA
80	140	26	2.0	1.0	87,500	70,000	4,000	6,000	7216BEA
	170	39	2.1	1.1	144,000	110,000	3,600	5,300	7316BEA

Angular Contact Ball Bearings – High Precision

Features compared with conventional bearings

- › Bearing life 15% higher
- › Universal Matching/Wide range combination is possible



Nomenclature

Example:

70 13 C TYN SU L P4

Bearing Series

79, 70, 72: Single-Row Angular Contact Ball Bearings

Bore

Bore number indicates bore diameter.
 00: 10mm; 01: 12mm; 02: 15mm;
 03: 17mm
 04 or Larger: Bore Number × 5 (mm)

Contact Angle

C: 15°; A5: 25°; A: 30°

Cage

TYN: Ball Guided Polyamide Resin Cage.
 Permissible $d_m n^*$ Value; 1,400,000.
 Continuous Operating Temperature Limit; 120 °C
 TR: Outer-Ring-Guided Phenolic Resin Cage.
 Continuous Operating Temperature Limit; 120 °C

Accuracy

P2: ISO Class 2 / P4: ISO Class 4
 P5: ISO Class 5 / P3: Special Class
 (Dimensional Accuracy: ISO Class 4/
 Running Accuracy: ISO Class 2)/
 P4Y: Special Class
 (Tolerances of Inner Ring Bore
 Diameter and Outer Ring Outside
 Diameter are controlled by NSK.
 Other Tolerances are ISO Class 4.)

Preload

EL: Extra Light Preload / L: Light Preload
 M: Medium Preload / H: Heavy Preload

Arrangement

SU: Universal Matching for Single Row
 DU: Universal Matching for Two Rows
 DB: Back-to-Back Matching
 DF: Face-to-Face Matching
 DT: Tandem Matching
 DBD, DFD, DTD: Three-Row Combination
 DBB, DFF, DBT, DFT, DTT: Four-Row Combination

Seals

None: Open Type / V1V: Noncontact Rubber Seal

* $d_m n = (\text{Bore diameter} + \text{Outside Diameter}) / 2 \times \text{Rotating Speed}$

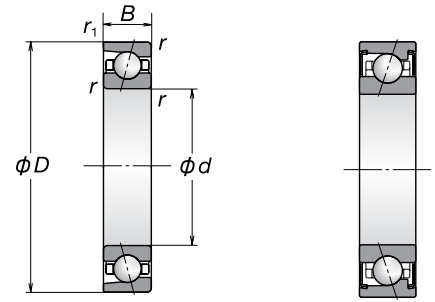

Open Type

Sealed Type

Boundary Dimensions (mm)					Basic Load Ratings (kN)		Limiting Speed (rpm)		Preload (DB,DF Arrangement) (N)				Bearing Numbers
d	D	B	r (min.)	r ₁ (min.)	C _r	C _{0r}	Grease	Oil	EL	L	M	H	
10	22	6	0.3	0.15	3.15	1.52	71,900	109,000	7	16	29	58	7900C
	22	6	0.3	0.15	3.00	1.45	62,500	93,800	10	17	55	94	7900A5
	26	8	0.3	0.15	5.60	2.49	63,900	97,300	13	25	49	96	7000C
	26	8	0.3	0.15	5.40	2.41	55,600	83,400	17	43	78	153	7000A5
	26	8	0.3	0.15	5.25	2.34	41,700	55,600	26	97	201	332	7000A
	30	9	0.6	0.3	5.65	2.61	57,500	87,500	13	29	68	150	7200C
	30	9	0.6	0.3	5.45	2.51	50,000	75,000	17	43	106	188	7200A5
12	30	9	0.6	0.3	5.30	2.44	37,500	50,000	26	97	201	-	7200A
	24	6	0.3	0.15	3.55	1.86	63,900	97,300	9	16	41	77	7901C
	24	6	0.3	0.15	3.35	1.77	55,600	83,400	16	25	59	120	7901A5
	28	8	0.3	0.15	6.10	2.90	57,500	87,500	13	25	57	120	7001C
	28	8	0.3	0.15	5.85	2.79	50,000	75,000	16	45	97	203	7001A5
	28	8	0.3	0.15	5.70	2.71	37,500	50,000	26	104	218	362	7001A
	32	10	0.6	0.3	8.30	3.85	52,300	79,600	20	40	100	195	7201C
15	32	10	0.6	0.3	8.05	3.70	45,500	68,200	34	56	145	287	7201A5
	32	10	0.6	0.3	7.85	3.65	34,100	45,500	26	104	218	361	7201A
	28	7	0.3	0.15	5.00	2.64	53,500	81,400	12	25	47	104	7902C
	28	7	0.3	0.15	4.75	2.53	46,600	69,800	16	35	74	141	7902A5
	32	9	0.3	0.15	6.55	3.40	49,000	74,500	12	29	66	147	7002C
	32	9	0.3	0.15	6.25	3.25	42,600	63,900	16	35	103	196	7002A5
	32	9	0.3	0.15	6.05	3.15	32,000	42,600	26	110	234	392	7002A
17	35	11	0.6	0.3	9.10	4.55	46,000	70,000	20	40	97	199	7202C
	35	11	0.6	0.3	8.75	4.35	40,000	60,000	35	73	196	392	7202A5
	35	11	0.6	0.3	8.50	4.25	30,000	40,000	26	111	236	394	7202A
	30	7	0.3	0.15	5.25	2.94	49,000	74,500	11	25	56	119	7903C
	30	7	0.3	0.15	5.00	2.80	42,600	63,900	15	35	77	149	7903A5
	35	10	0.3	0.15	6.95	3.80	44,300	67,400	15	30	69	156	7003C
	35	10	0.3	0.15	6.60	3.65	38,500	57,700	26	48	126	257	7003A5
20	35	10	0.3	0.15	6.40	3.50	28,900	38,500	26	116	251	422	7003A
	40	12	0.6	0.3	11.40	5.85	40,400	61,500	25	46	146	296	7203C
	40	12	0.6	0.3	11.00	5.60	35,100	52,700	35	75	204	407	7203A5
	40	12	0.6	0.3	10.70	5.45	26,400	35,100	26	115	246	412	7203A
	37	9	0.3	0.15	7.30	4.25	40,400	61,500	20	40	80	150	7904C
	37	9	0.3	0.15	6.95	4.05	35,100	52,700	25	65	115	245	7904A5
	42	12	0.6	0.3	11.7	6.55	37,100	56,500	25	50	120	245	7004C
25	42	12	0.6	0.3	11.2	6.25	32,300	48,400	35	80	205	405	7004A5
	42	12	0.6	0.3	10.8	6.10	24,200	32,300	25	130	280	475	7004A
	47	14	1.0	0.6	15.3	8.05	34,400	52,300	35	70	195	385	7204C
	47	14	1.0	0.6	14.7	7.75	29,900	44,800	65	110	290	595	7204A5
	47	14	1.0	0.6	14.3	7.55	22,400	29,900	25	260	440	650	7204A
	42	9	0.3	0.15	8.25	5.40	34,400	52,300	20	35	100	205	7905C
	42	9	0.3	0.15	7.80	5.15	29,900	44,800	40	70	155	290	7905A5
30	47	12	0.6	0.3	12.3	7.40	32,000	48,700	30	60	150	290	7005C
	47	12	0.6	0.3	11.7	7.10	27,800	41,700	50	105	195	395	7005A5
	47	12	0.6	0.3	11.3	6.85	20,900	27,800	25	135	300	505	7005A
	52	15	1.0	0.6	17.4	10.2	29,900	45,500	40	80	190	400	7205C
	52	15	1.0	0.6	16.7	9.80	26,000	39,000	80	140	330	690	7205A5
	52	15	1.0	0.6	16.1	9.45	19,500	26,000	50	360	580	840	7205A
	47	9	0.3	0.15	8.70	6.25	29,900	45,500	25	45	95	205	*7906C
30	47	9	0.3	0.15	8.25	5.95	26,000	39,000	40	75	140	285	*7906A5
	55	13	1.0	0.6	15.9	10.3	27,100	41,200	40	80	190	390	*7006C
	55	13	1.0	0.6	15.1	9.80	23,600	35,300	70	130	290	590	*7006A5
	55	13	1.0	0.6	14.6	9.45	17,700	23,600	50	190	390	640	*7006A
	62	16	1.0	0.6	24.2	14.7	25,000	38,100	60	110	290	590	7206C
	62	16	1.0	0.6	23.2	14.1	21,800	32,700	110	200	460	880	7206A5
62	16	1.0	0.6	22.4	13.6	16,400	21,800	50	380	620	910	7206A	

* Non-contact sealed design correspondence.
The limiting speeds listed table are guideline values. They are based on a single bearing that is lightly preloaded by means of a spring.

Angular Contact Ball Bearings – High Precision

Boundary Dimensions (mm)					Basic Load Ratings (kN)		Limiting Speed (rpm)		Preload (DB,DF Arrangement) (N)				Bearing Numbers
d	D	B	r (min.)	r ₁ (min.)	C _r	C _{or}	Grease	Oil	EL	L	M	H	
35	55	10	0.6	0.3	12.7	9.15	25,600	38,900	30	70	150	300	*7907C
	55	10	0.6	0.3	12.0	8.70	22,300	33,400	50	110	250	510	*7907A5
	62	14	1.0	0.6	20.1	13.7	23,800	36,100	60	120	250	490	*7007C
	62	14	1.0	0.6	19.1	13.0	20,700	31,000	70	160	390	780	*7007A5
	62	14	1.0	0.6	18.4	12.6	15,500	20,700	50	200	420	690	*7007A
	72	17	1.1	0.6	32.0	19.9	21,500	32,800	70	150	380	790	7207C
	72	17	1.1	0.6	30.5	19.1	18,700	28,100	130	240	600	1,180	7207A5
40	72	17	1.1	0.6	29.6	18.5	14,100	18,700	50	400	660	1,270	7207A
	62	12	0.6	0.3	15.9	11.7	22,600	34,400	40	80	200	380	*7908C
	62	12	0.6	0.3	15.0	11.2	19,700	29,500	70	110	290	570	*7908A5
	68	15	1.0	0.6	21.6	15.9	21,300	32,500	60	110	290	590	*7008C
	68	15	1.0	0.6	20.5	15.1	18,600	27,800	90	200	420	860	*7008A5
	68	15	1.0	0.6	19.7	14.6	13,900	18,600	50	220	460	770	*7008A
	80	18	1.1	0.6	38.0	25.2	19,200	29,200	100	200	500	980	7208C
45	80	18	1.1	0.6	36.5	24.1	16,700	25,000	140	290	750	1,490	7208A5
	80	18	1.1	0.6	35.5	23.4	12,500	16,700	50	440	720	1,430	7208A
	68	12	0.6	0.3	16.8	13.4	20,400	31,000	50	100	190	390	*7909C
	68	12	0.6	0.3	15.9	12.7	17,700	26,600	70	150	350	680	*7909A5
	75	16	1.0	0.6	25.6	19.3	19,200	29,200	80	140	340	690	*7009C
	75	16	1.0	0.6	24.3	18.3	16,700	25,000	90	210	480	960	*7009A5
	75	16	1.0	0.6	23.4	17.7	12,500	16,700	50	230	480	1,180	*7009A
50	85	19	1.1	0.6	43.0	28.8	17,700	27,000	120	250	530	1,070	7209C
	85	19	1.1	0.6	41.0	27.6	15,400	23,100	170	330	870	1,740	7209A5
	85	19	1.1	0.6	39.5	26.7	11,600	15,400	50	450	1,080	1,900	7209A
	72	12	0.6	0.3	17.7	15.0	18,900	28,700	50	90	240	500	*7910C
	72	12	0.6	0.3	16.7	14.2	16,400	24,600	70	150	380	790	*7910A5
	80	16	1.0	0.6	27.3	21.9	17,700	27,000	70	150	390	790	*7010C
	80	16	1.0	0.6	25.8	20.8	15,400	23,100	130	260	580	1,190	*7010A5
55	80	16	1.0	0.6	24.8	20.1	11,600	15,400	50	240	530	1,300	*7010A
	90	20	1.1	0.6	45.0	31.5	16,500	25,000	130	250	590	1,170	7210C
	90	20	1.1	0.6	43.0	30.5	14,300	21,500	210	390	990	1,930	7210A5
	90	20	1.1	0.6	41.5	29.3	10,800	14,300	50	480	1,160	2,040	7210A
	80	13	1.0	0.6	20.1	17.7	17,100	26,000	60	110	300	590	*7911C
	80	13	1.0	0.6	19.0	16.8	14,900	22,300	100	200	450	920	*7911A5
	90	18	1.1	0.6	36.0	28.6	15,900	24,200	90	200	480	970	*7011C
60	90	18	1.1	0.6	34.0	27.2	13,800	20,700	160	340	800	1,550	*7011A5
	90	18	1.1	0.6	32.5	26.3	10,400	13,800	50	250	890	1,310	*7011A
	100	21	1.5	1.0	55.5	40.0	14,900	22,600	140	290	790	1,550	7211C
	100	21	1.5	1.0	53.0	38.0	13,000	19,400	250	490	1,210	2,390	7211A5
	100	21	1.5	1.0	51.0	37.0	9,700	13,000	50	490	1,720	2,630	7211A
	85	13	1.0	0.6	20.4	18.7	15,900	24,200	60	110	300	590	*7912C
	85	13	1.0	0.6	19.2	17.7	13,800	20,700	100	200	420	880	*7912A5
65	95	18	1.1	0.6	37.0	30.5	14,900	22,600	100	190	530	1,090	*7012C
	95	18	1.1	0.6	35.0	29.1	13,000	19,400	160	360	780	1,550	*7012A5
	95	18	1.1	0.6	33.5	28.1	9,700	13,000	50	250	930	1,370	*7012A
	110	22	1.5	1.0	67.5	49.0	13,600	20,600	190	400	930	1,880	7212C
	110	22	1.5	1.0	64.0	47.0	11,800	17,700	290	610	1,460	2,930	7212A5
	110	22	1.5	1.0	62.0	45.5	8,900	11,800	50	510	1,700	2,740	7212A
	90	13	1.0	0.6	21.2	20.5	14,900	22,600	70	150	350	690	*7913C
70	90	13	1.0	0.6	20.0	19.4	13,000	19,400	100	210	500	950	*7913A5
	100	18	1.1	0.6	39.0	34.5	14,000	21,300	130	260	540	1,060	*7013C
	100	18	1.1	0.6	37.0	32.5	12,200	18,200	210	390	920	1,780	*7013A5
	100	18	1.1	0.6	35.5	31.5	9,100	12,200	50	270	1,010	1,500	*7013A
	120	23	1.5	1.0	77.0	58.5	12,500	19,000	220	450	1,070	2,170	7213C
	120	23	1.5	1.0	73.0	56.0	10,900	16,300	360	660	1,660	3,300	7213A5
	120	23	1.5	1.0	70.5	54.0	8,200	10,900	50	550	1,850	2,990	7213A

* Non-contact sealed design correspondence.
The limiting speeds listed table are guideline values. They are based on a single bearing that is lightly preloaded by means of a spring.

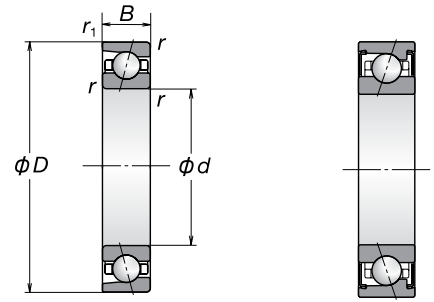

Open Type

Sealed Type

Boundary Dimensions (mm)					Basic Load Ratings (kN)		Limiting Speed (rpm)		Preload (DB,DF Arrangement) (N)				Bearing Numbers
d	D	B	r (min.)	r ₁ (min.)	C _r	C _{0r}	Grease	Oil	EL	L	M	H	
70	100	16	1.0	0.6	29.5	27.8	13,600	20,600	100	210	500	1,000	*7914C
	100	16	1.0	0.6	27.9	26.3	11,800	17,700	140	300	680	1,400	*7914A5
	110	20	1.1	0.6	49.0	43.0	12,800	19,500	150	280	730	1,460	*7014C
	110	20	1.1	0.6	46.5	41.0	11,200	16,700	250	500	1,080	2,200	*7014A5
	110	20	1.1	0.6	45.0	39.5	8,400	11,200	50	280	1,040	2,110	*7014A
	125	24	1.5	1.0	83.5	64.5	11,800	18,000	240	480	1,160	2,370	7214C
	125	24	1.5	1.0	79.5	61.5	10,300	15,400	410	780	1,850	3,690	7214A5
75	105	16	1.0	0.6	30.0	29.3	12,800	19,500	100	190	490	1,000	*7915C
	105	16	1.0	0.6	28.3	27.7	11,200	16,700	140	310	770	1,460	*7915A5
	115	20	1.1	0.6	50.5	45.5	12,200	18,500	150	290	800	1,570	*7015C
	115	20	1.1	0.6	47.5	43.5	10,600	15,800	260	520	1,200	2,400	*7015A5
	115	20	1.1	0.6	46.0	41.5	7,900	10,600	50	290	1,080	2,200	*7015A
	130	25	1.5	1.0	87.0	70.0	11,300	17,100	270	530	1,220	2,440	7215C
	130	25	1.5	1.0	82.5	66.5	9,800	14,700	420	820	1,960	3,910	7215A5
80	110	16	1.0	0.6	30.5	30.5	12,200	18,500	100	190	500	990	*7916C
	110	16	1.0	0.6	28.7	29.0	10,600	15,800	180	370	790	1,600	*7916A5
	125	22	1.1	0.6	61.5	55.5	11,300	17,100	200	380	920	1,880	*7016C
	125	22	1.1	0.6	58.5	52.5	9,800	14,700	350	620	1,510	2,900	*7016A5
	125	22	1.1	0.6	56.0	50.5	7,400	9,800	100	750	1,760	3,060	*7016A
	140	26	2.0	1.0	97.5	77.5	10,500	16,000	310	590	1,370	2,750	7216C
	140	26	2.0	1.0	93.0	74.0	9,100	13,700	460	920	2,160	4,340	7216A5
85	140	26	2.0	1.0	89.5	71.5	6,900	9,100	100	1,090	2,700	4,030	7216A
	120	18	1.1	0.6	41.0	40.5	11,300	17,100	140	310	630	1,280	*7917C
	120	18	1.1	0.6	38.5	38.5	9,800	14,700	230	430	950	1,910	*7917A5
	130	22	1.1	0.6	63.0	58.5	10,700	16,300	210	390	990	1,960	*7017C
	130	22	1.1	0.6	60.0	55.5	9,400	14,000	300	650	1,490	2,910	*7017A5
	130	22	1.1	0.6	57.5	53.5	7,000	9,400	100	780	1,840	3,200	*7017A
	150	28	2.0	1.0	113.0	90.5	9,800	14,900	360	700	1,660	3,360	7217C
90	150	28	2.0	1.0	107.0	86.5	8,600	12,800	530	1,090	2,430	4,880	7217A5
	150	28	2.0	1.0	104.0	83.5	6,400	8,600	100	1,130	3,470	5,790	7217A
	125	18	1.1	0.6	44.0	46.0	10,700	16,300	150	290	740	1,490	*7918C
	125	18	1.1	0.6	41.0	43.5	9,400	14,000	270	500	1,100	2,180	*7918A5
	140	24	1.5	1.0	75.5	69.0	10,000	15,300	250	500	1,190	2,370	*7018C
	140	24	1.5	1.0	71.0	65.5	8,700	13,100	410	780	1,760	3,500	*7018A5
	140	24	1.5	1.0	68.5	63.5	6,600	8,700	100	780	2,480	3,970	*7018A
95	160	30	2.0	1.0	129.0	105.0	9,200	14,000	380	770	1,860	3,710	7218C
	160	30	2.0	1.0	123.0	100.0	8,000	12,000	660	1,270	2,900	5,940	7218A5
	160	30	2.0	1.0	118.0	96.5	6,000	8,000	100	1,680	4,310	5,950	7218A
	130	18	1.1	0.6	44.5	48.0	10,300	15,600	150	290	800	1,590	*7919C
	130	18	1.1	0.6	42.0	45.5	8,900	13,400	230	510	1,220	2,370	*7919A5
	145	24	1.5	1.0	77.0	73.0	9,600	14,600	280	550	1,190	2,350	*7019C
	145	24	1.5	1.0	73.0	69.5	8,400	12,500	420	810	1,830	3,780	*7019A5
100	145	24	1.5	1.0	70.0	67.0	6,300	8,400	100	810	2,590	4,150	*7019A
	170	32	2.1	1.1	139.0	112.0	8,700	13,300	450	880	2,080	4,150	7219C
	170	32	2.1	1.1	133.0	107.0	7,600	11,400	700	1,390	3,120	6,300	7219A5
	170	32	2.1	1.1	128.0	103.0	5,700	7,600	360	1,630	4,190	6,640	7219A
	140	20	1.1	0.6	52.5	54.0	9,600	14,600	190	390	900	1,790	*7920C
	140	20	1.1	0.6	49.5	51.5	8,400	12,500	320	620	1,230	2,550	*7920A5
	150	24	1.5	1.0	79.0	77.0	9,200	14,000	280	530	1,280	2,570	*7020C
100	150	24	1.5	1.0	75.0	73.5	8,000	12,000	430	840	2,010	3,940	*7020A5
	150	24	1.5	1.0	72.0	70.5	6,000	8,000	100	840	2,700	4,330	*7020A
	180	34	2.1	1.1	157.0	127.0	8,300	12,500	500	980	2,340	4,700	7220C
	180	34	2.1	1.1	149.0	121.0	7,200	10,800	780	1,570	3,500	7,110	7220A5
180	34	2.1	1.1	144.0	117.0	5,400	7,200	360	1,660	5,050	7,680	7220A	

* Non-contact sealed design correspondence.
The limiting speeds listed table are guideline values. They are based on a single bearing that is lightly preloaded by means of a spring.

Angular Contact Ball Bearings – High Precision

Boundary Dimensions (mm)					Basic Load Ratings (kN)		Limiting Speed (rpm)		Preload (DB,DF Arrangement) (N)				Bearing Numbers
d	D	B	r (min.)	r ₁ (min.)	C _r	C _{0r}	Grease	Oil	EL	L	M	H	
105	145	20	1.1	0.6	53.5	57.0	9,200	14,000	190	400	890	1,790	7921C
	145	20	1.1	0.6	50.5	54.0	8,000	12,000	270	570	1,360	2,760	7921A5
	160	26	2.0	1.0	92.5	89.5	8,700	13,300	330	630	1,490	2,970	7021C
	160	26	2.0	1.0	87.5	85.0	7,600	11,400	490	990	2,210	4,470	7021A5
	160	26	2.0	1.0	84.0	81.5	5,700	7,600	100	840	2,690	4,310	7021A
	190	36	2.1	1.1	171.0	143.0	7,800	11,900	540	1,080	2,650	5,310	7221C
	190	36	2.1	1.1	163.0	137.0	6,800	10,200	860	1,790	3,950	7,930	7221A5
	190	36	2.1	1.1	157.0	132.0	5,100	6,800	370	2,300	5,200	8 920	7221A
110	150	20	1.1	0.6	54.5	59.5	8,900	13,500	200	400	920	1,850	7922C
	150	20	1.1	0.6	51.5	56.0	7,700	11,600	330	650	1,500	2,990	7922A5
	170	28	2.0	1.0	111.0	104.0	8,300	12,500	370	730	1,750	3,520	7022C
	170	28	2.0	1.0	105.0	99.0	7,200	10,800	600	1,190	2,660	5,250	7022A5
	170	28	2.0	1.0	101.0	95.5	5,400	7,200	100	1,330	3,330	5,950	7022A
	200	38	2.1	1.1	185.0	160.0	7,500	11,300	630	1,280	2,960	5,900	7222C
	200	38	2.1	1.1	176.0	153.0	6,500	9,700	950	2,010	4,400	9,390	7222A5
	200	38	2.1	1.1	170.0	148.0	4,900	6,500	370	2,350	6,200	10,180	7222A
120	165	22	1.1	0.6	75.5	81.0	8,100	12,300	270	540	1,290	2,540	7924C
	165	22	1.1	0.6	71.0	77.0	7,100	10,600	460	900	1,960	3,880	7924A5
	180	28	2.0	1.0	118.0	117.0	7,700	11,700	420	830	1,960	3,920	7024C
	180	28	2.0	1.0	111.0	111.0	6,700	10,000	650	1,290	2,900	5,920	7024A5
	180	28	2.0	1.0	107.0	107.0	5,000	6,700	100	1,440	3,640	6,530	7024A
	215	40	2.1	1.1	209.0	192.0	6,900	10,500	690	1,390	3,210	6,370	7224C
	215	40	2.1	1.1	199.0	184.0	6,000	9,000	1,140	2,330	5,260	10 290	7224A5
	215	40	2.1	1.1	192.0	177.0	4,500	6,000	540	2,810	8 150	11,540	7224A
130	180	24	1.5	1.0	82.5	91.0	7,500	11,300	330	650	1,470	2,940	7926C
	180	24	1.5	1.0	78.0	86.0	6,500	9,700	470	1,010	2,120	4,280	7926A5
	200	33	2.0	1.0	136.0	137.0	7,000	10,700	490	970	2,250	4,520	7026C
	200	33	2.0	1.0	128.0	130.0	6,100	9,100	820	1,540	3,410	6,840	7026A5
	200	33	2.0	1.0	123.0	125.0	4,600	6,100	100	1,490	4,720	7,940	7026A
	230	40	3.0	1.1	217.0	209.0	6,400	9,800	750	1,510	3,390	6,740	7226C
	230	40	3.0	1.1	206.0	199.0	5,600	8,400	1,190	2,450	5,570	10 920	7226A5
	230	40	3.0	1.1	199.0	193.0	4,200	5,600	560	3,760	9 800	13,570	7226A
140	190	24	1.5	1.0	83.5	95.5	7,000	10,700	330	630	1,460	2,960	7928C
	190	24	1.5	1.0	78.5	90.0	6,100	9,100	480	950	2,200	4,430	7928A5
	210	33	2.0	1.0	139.0	145.0	6,600	10,000	500	1,000	2,330	4,790	7028C
	210	33	2.0	1.0	131.0	138.0	5,800	8,600	790	1,520	3,440	6,820	7028A5
	210	33	2.0	1.0	126.0	133.0	4,300	5,800	200	1,780	5,270	8,710	7028A
	250	42	3.0	1.1	250.0	254.0	5,900	9,000	910	1,830	4,080	8,300	7228C
	250	42	3.0	1.1	238.0	242.0	5,200	7,700	1,500	3,010	6,730	13,400	7228A5
	250	42	3.0	1.1	229.0	234.0	3,900	5,200	570	4,990	11,440	15,510	7228A

* Non-contact sealed design correspondence.
The limiting speeds listed table are guideline values. They are based on a single bearing that is lightly preloaded by means of a spring.

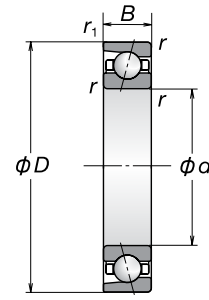

Open Type

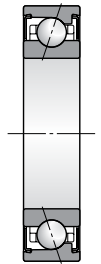

Sealed Type

Boundary Dimensions (mm)					Basic Load Ratings (kN)		Limiting Speed (rpm)		Preload (DB,DF Arrangement) (N)				Bearing Numbers
d	D	B	r (min.)	r ₁ (min.)	C _r	C _{0r}	Grease	Oil	EL	L	M	H	
150	210	28	2.0	1.0	107.0	122.0	6,400	9,800	390	820	1,970	3,990	7930C
	210	28	2.0	1.0	101.0	115.0	5,600	8,400	650	1,270	2,910	5,910	7930A5
	225	35	2.1	1.1	158.0	168.0	6,200	9,400	580	1,150	2,560	5,100	7030C
	225	35	2.1	1.1	150.0	160.0	5,400	8,000	930	1,850	4,070	8,250	7030A5
	225	35	2.1	1.1	144.0	154.0	4,000	5,400	200	1,830	5,850	11,700	7030A
	270	45	3.0	1.1	284.0	305.0	5,500	8,400	1,090	2,200	4,950	9,980	7230C
	270	45	3.0	1.1	270.0	290.0	4,800	7,200	1,850	3,640	8,040	16,460	7230A5
160	270	45	3.0	1.1	261.0	280.0	3,600	4,800	590	5,000	11,910	16,140	7230A
	220	28	2.0	1.0	112.0	133.0	6,100	9,300	430	860	1,950	3,880	7932C
	220	28	2.0	1.0	105.0	125.0	5,300	7,900	680	1,340	3,250	6,330	7932A5
	240	38	2.1	1.1	180.0	193.0	5,800	8,800	620	1,270	2,970	5,800	7032C
	240	38	2.1	1.1	170.0	183.0	5,000	7,500	1,090	2,170	4,720	9,440	7032A5
	240	38	2.1	1.1	163.0	176.0	3,800	5,000	200	1,880	5,600	12,070	7032A
	230	28	2.0	1.0	118.0	148.0	5,800	8,800	490	970	2,180	4,330	7934C
170	230	28	2.0	1.0	112.0	140.0	5,000	7,500	810	1,560	3,550	7,170	7934A5
	260	42	2.1	1.1	215.0	234.0	5,400	8,200	780	1,570	3,600	7,110	7034C
	260	42	2.1	1.1	203.0	223.0	4,700	7,000	1,290	2,550	5,930	11,670	7034A5
	260	42	2.1	1.1	195.0	214.0	3,500	4,700	200	2,700	6,080	12,110	7034A
180	250	33	2.0	1.0	152.0	184.0	5,400	8,200	590	1,140	2,660	5,370	7936C
	250	33	2.0	1.0	144.0	174.0	4,700	7,000	990	2,020	4,440	8,880	7936A5
	280	46	2.1	1.1	240.0	276.0	5,000	7,700	940	1,880	4,200	8,280	7036C
	280	46	2.1	1.1	227.0	262.0	4,400	6,600	1,580	3,130	6,880	13,680	7036A5
	280	46	2.1	1.1	218.0	252.0	3,300	4,400	200	3,620	7,230	14,210	7036A
190	260	33	2.0	1.0	155.0	192.0	5,200	7,800	600	1,220	2,820	5,650	7938C
	260	33	2.0	1.0	146.0	182.0	4,500	6,700	1,010	2,080	4,580	9,180	7938A5
	290	46	2.1	1.1	259.0	305.0	4,800	7,300	1,040	2,090	4,680	9,300	7038C
	290	46	2.1	1.1	245.0	291.0	4,200	6,300	1,720	3,640	7,610	15,230	7038A5
	290	46	2.1	1.1	235.0	280.0	3,200	4,200	200	3,890	8,160	16,180	7038A
200	280	38	2.1	1.1	199.0	244.0	4,800	7,300	780	1,640	3,680	7,170	7940C
	280	38	2.1	1.1	187.0	231.0	4,200	6,300	1,260	2,550	5,850	11,660	7940A5
	310	51	2.1	1.1	278.0	340.0	4,600	6,900	1,150	2,310	5,200	10,290	7040C
	310	51	2.1	1.1	263.0	325.0	4,000	5,900	1,880	3,710	8,390	16,910	7040A5
	310	51	2.1	1.1	252.0	310.0	3,000	4,000	200	5,060	13,450	26,690	7040A
220	300	38	2.1	1.1	200.0	256.0	4,500	6,800	850	1,750	4,070	7,270	7944C
	300	38	2.1	1.1	188.0	242.0	3,900	5,800	1,290	2,630	6,250	12,340	7944A5
240	320	38	2.1	1.1	210.0	286.0	4,200	6,300	900	1,820	4,130	8,230	7948C
	320	38	2.1	1.1	198.0	270.0	3,600	5,400	1,385	2,860	6,620	13,260	7948A5
260	360	46	2.1	1.1	268.0	365.0	3,800	5,700	1,180	2,360	5,290	10,650	7952C
	360	46	2.1	1.1	253.0	345.0	3,300	4,900	1,930	3,870	8,700	17,380	7952A5
280	380	46	2.1	1.1	285.0	410.0	3,500	5,400	1,320	2,650	6,020	11,970	7956C
	380	46	2.1	1.1	269.0	390.0	3,100	4,600	2,110	4,220	9,740	19,260	7956A5

* Non-contact sealed design correspondence.
The limiting speeds listed table are guideline values. They are based on a single bearing that is lightly preloaded by means of a spring.

Ball Screw Support Angular Contact Thrust Ball Bearings

Features compared with conventional bearings

- › Bearing life* 15% higher
- › Universal Matching/Wide Range combination is possible

* Basic Rating Life



Nomenclature

Example:

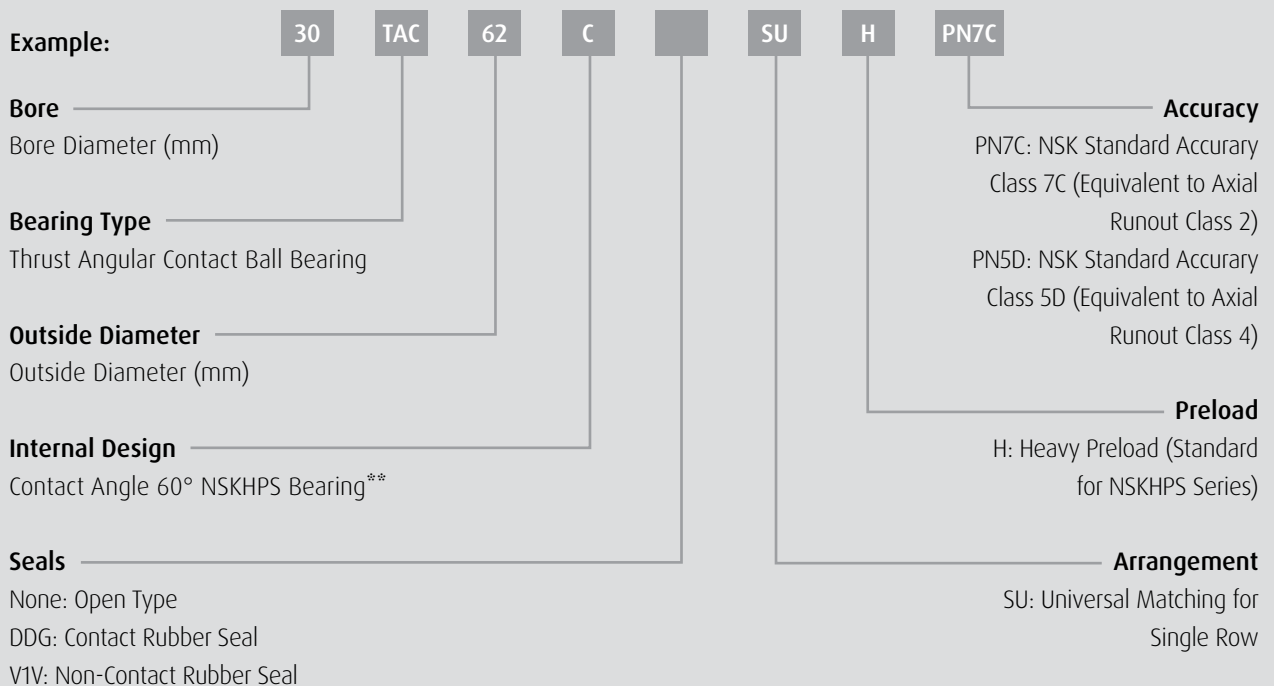

** SUJ2 steel is adopted as standard in this bearings.

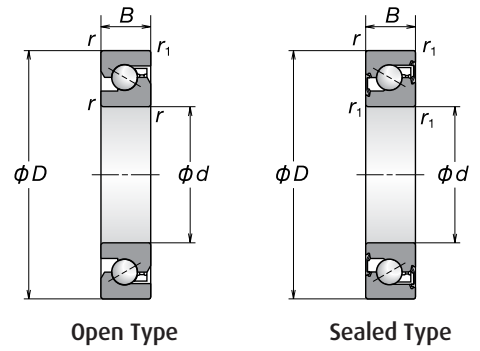

Open Type

Sealed Type

Boundary Dimensions (mm)					Basic Load Ratings C_a (kN)	Limiting Speed (rpm)		Recommended Grease Amount (cc)	Limiting Axial Load (kN)	Preload (DB,DF Arrangement) (N)	Axial Rigidity (DB,DF Arrangement) (N/ μ m)	Starting Torque (N·m)	Bearing Numbers
d	D	B	r (min.)	r_1 (min.)		Grease	Oil			H	H	H	
15	47	15	1	0.6	23.0	6,900	9,200	2.2	26.6	1,450	630	0.09	*15TAC47C
17	47	15	1	0.6	23.0	6,900	9,200	2.2	26.6	1,450	630	0.09	*17TAC47C
20	47	15	1	0.6	23.0	6,900	9,200	2.2	26.6	1,450	630	0.09	*20TAC47C
25	62	15	1	0.6	29.9	5,200	6,900	3.0	40.5	2,280	850	0.15	*25TAC62C
30	62	15	1	0.6	30.5	4,900	6,400	3.2	43.0	2,400	890	0.16	*30TAC62C
35	72	15	1	0.6	32.5	4,100	5,800	3.8	50.0	2,750	1,030	0.18	*35TAC72C
40	72	15	1	0.6	33.5	4,100	5,500	3.9	52.0	2,860	1,080	0.19	*40TAC72C
	90	20	1	0.6	62.0	3,500	4,600	8.8	89.5	3,450	1,150	0.29	*40TAC90C
45	75	15	1	0.6	34.5	3,700	4,900	4.2	57.0	3,100	1,170	0.20	45TAC75C
	100	20	1	0.6	64.5	3,000	4,100	9.7	99.0	4,440	1,340	0.40	*45TAC100C
50	100	20	1	0.6	66.0	3,000	3,900	10.2	104.0	4,650	1,410	0.42	*50TAC100C
55	100	20	1	0.6	66.0	3,000	3,900	10.2	104.0	4,650	1,410	0.42	*55TAC100C
	120	20	1	0.6	70.5	2,500	3,500	12.0	123.0	5,450	1,660	0.49	55TAC120C
60	120	20	1	0.6	70.5	2,500	3,500	12.0	123.0	5,450	1,660	0.49	60TAC120C

* Bearing numbers denoted by an asterisk represent availability of either a contact rubber seal or a non-contact rubber seal. The value of limiting speed is for when H preload is applied. This value is uninfluenced by the type of arrangement. Starting torque shows the numerical value for grease lubrication. Under conditions of oil lubrication, starting torque becomes 1.4 times that of the figures listed above. Permissible axial load becomes 0.7 times that of limiting axial load.

Cylindrical Roller Bearings

Features compared with conventional bearings

- › Bearing life 60% higher



Nomenclature

Example:

NU3

08

E

T7

C3

U537

Bearing

NU2, NU22, NU3, NU23,
NJ2, NJ22, NJ3, NJ23, NUP2,
NUP22, NUP3, NUP23:
Cylindrical Roller Bearings

Bore

Bore number indicates bore diameter.
Bore number × 5 (mm)

Internal Design

E: High Load Capacity

NSKHPS

U537: NSKHPS Bearings

Internal Clearance

Omitted: CN Clearance
C3: Clearance greater than CN
C4: Clearance greater than C3

Cage

W: Pressed Steel Cage
M: Machined Brass Cage
T: Polyamide Resin Cage
T7: L-PPS Resin Cage

Boundary Dimensions (mm)						Basic Load Ratings (N)		Limiting Speed (rpm)		Permissible Axial Movement S (mm)	Bearing Numbers	Cage			
d	D	B	r (min.)	r ₁ (min.)	Fw	C _r	C _{0r}	Grease	Oil			W	M	T	T7
25	52	15	1.0	0.6	31.5	33,500	27,700	12,000	14,000	1.2	205E	*	*	*	*
	52	18	1.0	0.6	31.5	40,000	34,500	12,000	14,000	1.2	2205E	*	*	*	*
	62	17	1.1	1.1	34.0	48,000	37,500	10,000	12,000	1.2	305E	*	*	*	*
	62	24	1.1	1.1	34.0	65,500	56,000	9,000	11,000	1.2	2305E	*	*	*	*
30	62	16	1.0	0.6	37.5	45,000	37,500	9,500	12,000	1.2	206E	*	*	*	*
	62	20	1.0	0.6	37.5	56,500	50,000	9,500	12,000	1.2	2206E	*	*	*	*
	72	19	1.1	1.1	40.5	61,000	50,000	8,500	10,000	1.2	306E	*	*	*	*
	72	27	1.1	1.1	40.5	86,000	77,500	8,000	9,500	1.2	2306E	*	*	*	*

* Available cage

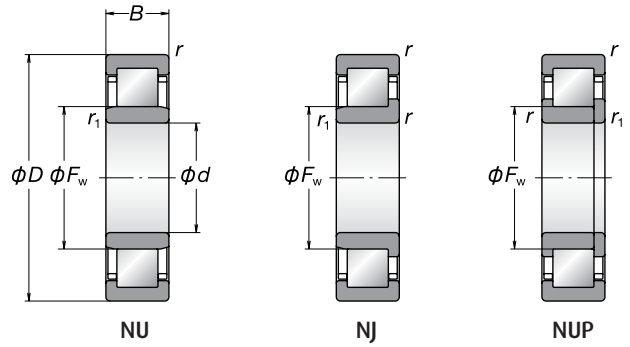

Boundary Dimensions (mm)						Basic Load Ratings (N)		Limiting Speed (rpm)		Permissible Axial Movement S (mm)	Bearing Numbers	Cage			
d	D	B	r (min.)	r ₁ (min.)	F _w	C _r	C _{0r}	Grease	Oil			W	M	T	T7
35	72	17	1.1	0.6	44.0	58,000	50,000	8,500	10,000	1.2	207E	*	*	*	*
	72	23	1.1	0.6	44.0	71,000	65,500	8,500	10,000	2.2	2207E		*	*	*
	80	21	1.5	1.1	46.2	76,500	65,500	7,500	9,500	1.2	307E	*	*	*	*
	80	31	1.5	1.1	46.2	107,000	101,000	6,700	8,500	1.2	2307E		*	*	*
40	80	18	1.1	1.1	49.5	64,000	55,500	7,500	9,000	1.2	208E	*	*	*	*
	80	23	1.1	1.1	49.5	83,000	77,500	7,500	9,000	1.2	2208E		*	*	*
	90	23	1.5	1.5	52.0	95,500	81,500	6,700	8,000	1.2	308E	*	*	*	*
	90	33	1.5	1.5	52.0	131,000	122,000	6,000	7,500	1.2	2308E		*	*	*
45	85	19	1.1	1.1	54.5	72,500	66,500	6,700	8,000	1.2	209E	*	*	*	*
	85	23	1.1	1.1	54.5	87,500	84,500	6,700	8,500	1.2	2209E		*	*	*
	100	25	1.5	1.5	58.5	112,000	98,500	6,000	7,500	1.4	309E	*	*	*	*
	100	36	1.5	1.5	58.5	158,000	153,000	5,300	6,700	1.4	2309E		*	*	*
50	90	20	1.1	1.1	59.5	79,500	76,500	6,300	7,500	1.7	210E	*	*	*	*
	90	23	1.1	1.1	59.5	96,000	97,000	6,300	8,000	1.2	2210E		*	*	*
	110	27	2.0	2.0	65.0	127,000	113,000	5,000	6,000	1.4	310E	*	*	*	*
	110	40	2.0	2.0	65.0	187,000	187,000	5,000	6,300	1.4	2310E		*	*	*
55	100	21	1.5	1.1	66.0	99,000	98,500	5,600	7,100	1.2	211E	*	*	*	*
	100	25	1.5	1.1	66.0	117,000	122,000	5,600	7,100	1.2	2211E		*	*	*
	120	29	2.0	2.0	70.5	158,000	143,000	4,500	5,600	1.4	311E	*	*	*	*
	120	43	2.0	2.0	70.5	231,000	233,000	4,500	5,600	1.4	2311E		*	*	*
60	110	22	1.5	1.5	72.0	112,000	107,000	5,300	6,300	1.2	212E	*	*	*	*
	110	28	1.5	1.5	72.0	151,000	157,000	5,300	6,300	1.2	2212E		*	*	*
	130	31	2.1	2.1	77.0	169,000	157,000	4,800	5,600	1.5	312E		*	*	*
	130	46	2.1	2.1	77.0	251,000	262,000	4,300	5,300	1.5	2312E		*	*	*
65	120	23	1.5	1.5	78.5	124,000	119,000	4,800	5,600	1.4	213E	*	*	*	*
	120	31	1.5	1.5	78.5	171,000	181,000	4,800	6,000	1.4	2213E		*	*	*
	140	33	2.1	2.1	82.5	204,000	191,000	4,300	5,300	1.5	313E		*	*	*
	140	48	2.1	2.1	82.5	263,000	265,000	3,800	4,800	1.5	2313E		*	*	*
70	125	24	1.5	1.5	83.5	136,000	137,000	5,000	6,300	1.4	214E		*	*	*
	125	31	1.5	1.5	83.5	179,000	194,000	4,500	5,600	1.4	2214E		*	*	*
	150	35	2.1	2.1	89.0	231,000	222,000	4,000	5,000	1.5	314E		*	*	*
	150	51	2.1	2.1	89.0	310,000	325,000	3,600	4,500	1.5	2314E		*	*	*
75	130	25	1.5	1.5	88.5	150,000	156,000	4,800	6,000	1.4	215E		*	*	*
	130	31	1.5	1.5	88.5	186,000	207,000	4,300	5,300	1.4	2215E		*	*	*
	160	37	2.1	2.1	95.0	271,000	263,000	3,800	4,800	1.4	315E		*	*	*
	160	55	2.1	2.1	95.0	370,000	395,000	3,400	4,300	4.4	2315E		*	*	*
80	140	26	2.0	2.0	95.3	160,000	167,000	4,500	5,300	1.4	216E		*	*	*
	140	33	2.0	2.0	95.3	214,000	243,000	4,000	5,000	1.4	2216E		*	*	*
	170	39	2.1	2.1	101.0	289,000	282,000	3,600	4,300	1.5	316E		*	*	*
	170	58	2.1	2.1	101.0	400,000	430,000	3,200	4,000	1.5	2316E		*	*	*
85	150	28	2.0	2.0	100.5	192,000	199,000	4,300	5,000	0.8	217E		*	*	*
	150	36	2.0	2.0	100.5	250,000	279,000	3,800	4,500	1.3	2217E		*	*	*
90	160	30	2.0	2.0	107.0	205,000	217,000	4,000	4,800	1.4	218E		*	*	*
	160	40	2.0	2.0	107.0	274,000	315,000	3,600	4,300	1.9	2218E		*	*	*
95	170	32	2.1	2.1	112.5	249,000	265,000	3,800	4,500	1.4	219E		*	*	*
	170	43	2.1	2.1	112.5	325,000	370,000	3,400	4,000	1.4	2219E		*	*	*

* Available cage

Deep Groove Ball Bearings

Features compared with conventional bearings

- › Bearing life 15% higher
- › Limiting Speed / 15% higher^{*1}



Nomenclature

Example:

Bearing

60, 62, 63: Single-Row Deep Groove Ball Bearings

Bore

Bore number indicates bore diameter.
 00: 10mm; 01: 12mm; 02: 15mm; 03: 17mm
 04 or Larger: Bore Number x 5 (mm)

NSKHPS

+: NSKHPS Bearings

62 03 + ZZ CM NS7S

Grease

NS7: NS Hi-Lube

Internal Clearance

Omitted: CN Clearance^{*2}
 C3: Clearance greater than CN /
 C4: Clearance greater than C3
 CM: For Electric Motors^{*2}

Seals, Shields

ZZ: Shield on both side
 DDU: Contact Rubber Seal on both side
 VV: Non-Contact Rubber Sealed on both side

Boundary Dimensions (mm)				Basic Load Ratings (N)		Factor	Limiting Speed (rpm)			Bearing Numbers			
d	D	B	r (min.)	C _r	C _{0r}	f ₀	Grease		Oil	Open	Shielded	Sealed	
							Open	ZZ	DDU				
							ZZ	VV					
10	30	9	0.6	5,350	2,390	13.2	28,000	18,000	34,000	6200+	ZZ	VV	DDU
	35	11	0.6	8,500	3,450	11.2	26,000	17,000	30,000	6300+	ZZ	VV	DDU
12	28	8	0.3	5,350	2,370	13.0	32,000	18,000	38,000	6001+	ZZ	VV	DDU
	32	10	0.6	7,150	3,050	12.3	26,000	17,000	32,000	6201+	ZZ	VV	DDU
15	37	12	1.0	10,200	4,200	11.1	24,000	16,000	28,000	6301+	ZZ	VV	DDU
	32	9	0.3	5,850	2,830	13.9	26,000	15,000	32,000	6002+	ZZ	VV	DDU
	35	11	0.6	8,000	3,750	13.2	22,000	14,000	28,000	6202+	ZZ	VV	DDU
	42	13	1.0	12,000	5,450	12.3	20,000	13,000	24,000	6302+	ZZ	VV	DDU
17	35	10	0.3	6,300	3,250	14.4	24,000	13,000	28,000	6003+	ZZ	VV	DDU
	40	12	0.6	10,100	4,800	13.2	20,000	12,000	24,000	6203+	ZZ	VV	DDU
	47	14	1.0	14,300	6,650	12.4	18,000	11,000	20,000	6303+	ZZ	VV	DDU
20	42	12	0.6	9,850	5,000	13.8	20,000	11,000	24,000	6004+	ZZ	VV	DDU
	47	14	1.0	13,400	6,600	13.1	17,000	11,000	20,000	6204+	ZZ	VV	DDU
	52	15	1.1	16,700	7,900	12.4	16,000	10,000	19,000	6304+	ZZ	VV	DDU
25	47	12	0.6	10,600	5,850	14.5	18,000	9,500	22,000	6005+	ZZ	VV	DDU
	52	15	1.0	14,700	7,850	13.9	15,000	9,000	18,000	6205+	ZZ	VV	DDU
	62	17	1.1	21,600	11,200	13.2	13,000	8,000	16,000	6305+	ZZ	VV	DDU
30	55	13	1.0	13,900	8,300	14.7	15,000	8,000	18,000	6006+	ZZ	VV	DDU
	62	16	1.0	20,400	11,300	13.8	12,000	7,500	15,000	6206+	ZZ	VV	DDU
	72	19	1.1	28,000	15,000	13.3	11,000	6,700	13,000	6306+	ZZ	VV	DDU

Notes: ^{*1} Limiting speeds of the DDU contact seals are equal to those of conventional bearings
^{*2} The CM clearance can be used in substitute of the CN clearance (the opposite is not available).

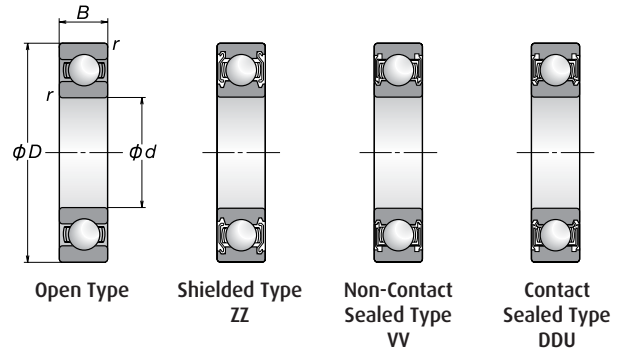

$\frac{f_0 F_a}{C_0 r}$	e	$\frac{F_a}{F_r} \leq e$		$\frac{F_a}{F_r} > e$	
		X	Y	X	Y
0.172	0.19	1	0	0.56	2.30
0.345	0.22	1	0	0.56	1.99
0.689	0.26	1	0	0.56	1.71
1.030	0.28	1	0	0.56	1.55
1.380	0.30	1	0	0.56	1.45
2.070	0.34	1	0	0.56	1.31
3.450	0.38	1	0	0.56	1.15
5.170	0.42	1	0	0.56	1.04
6.890	0.44	1	0	0.56	1.00

Dynamic Equivalent Load

$$P = XF_r + YF_a$$

Static Equivalent Load

$$P_0 = 0.6F_r + 0.5F_a$$

When $F_r > 0.6F_r + 0.5F_a$, use $P_0 = F_r$.

Boundary Dimensions (mm)				Basic Load Ratings (N)		Factor	Limiting Speed (rpm)			Bearing Numbers			
d	D	B	r (min.)	C _r	C _{0r}	f ₀	Grease		Oil	Open	Shielded	Sealed	DDU
							Open ZZ VV	DDU	Open				
35	62	14	1.0	16,800	10,300	14.8	13,000	6,700	15,000	6007+	ZZ	VV	DDU
	72	17	1.1	27,000	15,300	13.8	11,000	6,300	13,000	6207+	ZZ	VV	DDU
	80	21	1.5	35,000	19,200	13.2	10,000	6,000	12,000	6307+	ZZ	VV	DDU
40	68	15	1.0	17,600	11,500	15.3	12,000	6,000	14,000	6008+	ZZ	VV	DDU
	80	18	1.1	30,500	17,900	14.0	9,500	5,600	12,000	6208+	ZZ	VV	DDU
	90	23	1.5	43,000	24,000	13.2	9,000	5,300	11,000	6308+	ZZ	VV	DDU
45	75	16	1.0	22,000	15,200	15.3	10,000	5,300	12,000	6009+	ZZ	VV	DDU
	85	19	1.1	33,000	20,400	14.4	9,000	5,300	11,000	6209+	ZZ	VV	DDU
	100	25	1.5	55,500	32,000	13.1	8,000	4,800	9,500	6309+	ZZ	VV	DDU
50	80	16	1.0	22,900	16,600	15.6	9,500	4,800	11,000	6010+	ZZ	VV	DDU
	90	20	1.1	37,000	23,200	14.4	8,500	4,800	10,000	6210+	ZZ	VV	DDU
	110	27	2.0	65,000	38,500	13.2	7,100	4,300	8,500	6310+	ZZ	VV	DDU
55	90	18	1.1	29,700	21,200	15.3	8,500	4,500	10,000	6011+	ZZ	VV	DDU
	100	21	1.5	45,500	29,300	14.3	7,500	4,300	9,000	6211+	ZZ	VV	DDU
	120	29	2.0	75,000	44,500	13.1	6,700	4,000	8,000	6311+	ZZ	VV	DDU
60	95	18	1.1	31,000	23,200	15.6	8,000	4,000	9,500	6012+	ZZ	VV	DDU
	110	22	1.5	55,000	36,000	14.3	6,700	3,800	8,000	6212+	ZZ	VV	DDU
	130	31	2.1	86,000	52,000	13.1	6,000	3,600	7,100	6312+	ZZ	VV	DDU
65	100	18	1.1	32,000	25,200	15.8	7,500	4,000	9,000	6013+	ZZ	VV	DDU
	120	23	1.5	60,000	40,000	14.4	6,300	3,600	7,500	6213+	ZZ	VV	DDU
	140	33	2.1	97,500	60,000	13.2	5,600	3,400	6,700	6313+	ZZ	VV	DDU
70	110	20	1.1	40,000	31,000	15.6	7,100	3,600	8,500	6014+	ZZ	VV	DDU
	125	24	1.5	65,500	44,000	14.5	6,000	3,400	7,100	6214+	ZZ	VV	DDU
	150	35	2.1	109,000	68,000	13.2	5,300	3,200	6,300	6314+	ZZ	VV	DDU
75	115	20	1.1	41,500	33,500	15.8	6,700	3,400	8,000	6015+	ZZ	VV	DDU
	130	25	1.5	69,500	49,500	14.7	5,600	3,200	6,700	6215+	ZZ	VV	DDU
	160	37	2.1	119,000	77,000	13.2	5,000	2,800	6,000	6315+	ZZ	VV	DDU
80	125	22	1.1	50,000	40,000	15.6	6,000	3,200	7,500	6016+	ZZ	VV	DDU
	140	26	2.0	76,500	53,000	14.6	5,300	3,000	6,300	6216+	ZZ	VV	DDU
	170	39	2.1	129,000	86,500	13.3	4,500	2,800	5,600	6316+	ZZ	VV	DDU
85	130	22	1.1	52,000	43,000	15.8	6,000	3,000	7,100	6017+	ZZ	VV	DDU
	150	28	2.0	88,000	62,000	14.5	5,000	2,800	6,000	6217+	ZZ	VV	DDU
	180	41	3.0	139,000	97,000	13.3	4,300	2,600	5,000	6317+	ZZ	VV	DDU
90	140	24	1.5	61,000	50,000	15.6	5,300	2,800	6,300	6018+	ZZ	VV	DDU
	160	30	2.0	101,000	71,500	14.5	4,500	2,600	5,600	6218+	ZZ	VV	DDU
	190	43	3.0	150,000	107,000	13.3	4,000	2,400	4,800	6318+	ZZ	VV	DDU
95	145	24	1.5	63,500	54,000	15.8	5,000	2,600	6,000	6019+	ZZ	VV	DDU
	170	32	2.1	114,000	82,000	14.4	4,300	2,600	5,000	6219+	ZZ	VV	DDU
	200	45	3.0	160,000	119,000	13.3	3,400	2,400	4,300	6319+	ZZ	VV	DDU
100	150	24	1.5	63,000	54,000	15.9	5,000	2,600	6,000	6020+	ZZ	VV	DDU
	180	34	2.1	128,000	93,000	14.4	4,000	2,400	4,800	6220+	ZZ	VV	DDU
	210	48	3.0	180,000	128,000	13.3	3,400	2,400	4,300	6320+	ZZ	VV	DDU
105	160	26	2.0	76,000	66,000	15.8	4,500	2,400	5,600	6021+	ZZ	VV	DDU
	190	36	2.1	140,000	105,000	14.4	3,800	2,200	4,500	6221+	ZZ	VV	DDU
	220	48	3.0	200,000	140,000	13.3	3,400	2,400	4,300	6321+	ZZ	VV	DDU
110	170	28	2.0	89,000	73,000	15.5	4,500	2,200	5,300	6022+	ZZ	VV	DDU
	200	38	2.1	150,000	105,000	14.4	4,000	2,400	4,800	6222+	ZZ	VV	DDU
	230	50	3.0	210,000	140,000	13.3	3,400	2,400	4,300	6322+	ZZ	VV	DDU
120	180	28	2.0	92,500	80,000	15.7	4,000	2,200	5,000	6024+	ZZ	VV	DDU

Spherical Roller Bearings

Features compared with conventional bearings

- › Bearing Life 2 times
- › Limiting Speed 20% higher*
- › Working Temperature up to 200 °C

*Limiting speeds of the CA-design bearings are equal to those of conventional bearings



Nomenclature

Example:

232 36 CA M K E4 C3 S11 *H*

Bearing

239, 230, 240, 231, 241, 222, 232, 213, 223: Spherical Roller Bearings

Bore

Bore number indicates bore diameter.
Bore Number x 5 (mm)

Internal Design

EA, CA: High Load Capacity

Cage

M: Machined Brass Cage (for CA Design)
Omitted: Pressed Steel Cage (for EA Design)

Design of Rings

K: Tapered Bore of inner ring (Taper 1:12)
K30: Tapered Bore of inner ring (Taper 1:30)
E4: Lubricating Groove in outside surface and holes in outer ring

NSKHPS

H: NSKHPS Bearings

Special Specification

S11: Dimensional Stabilizing Treatment
Working Temperature Lower than 200 °C (Although S11 symbol is omitted in the EA design, special heat treatment of S11 is done)

Internal Clearance

C2: Clearance less than CN
Omitted: CN Clearance
C3: Clearance greater than CN
C4: Clearance greater than C3
C5: Clearance greater than C4

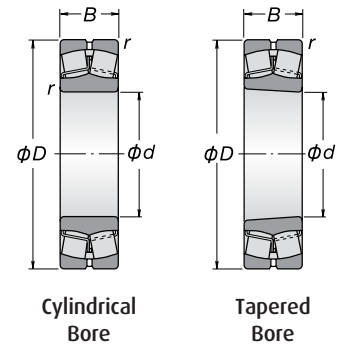
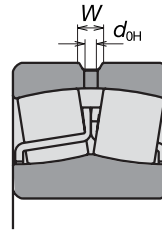

Table 1: Dimensions of Oil Groove and Holes

Nominal Width B		Oil Groove Width W	Hole Diameter d_{OH}
Over	Incl.		
18	30	5.0	2.5
30	40	6.0	3.0
40	50	7.0	4.0
50	65	8.0	5.0
65	80	10.0	6.0
80	100	12.0	8.0
100	120	15.0	10.0
120	160	20.0	12.0
160	200	25.0	15.0
200	250	30.0	20.0
250	315	35.0	20.0
315	400	40.0	25.0
400	-	40.0	25.0

Unit: mm

Table 2: Number of Oil Holes



Nominal Outer Ring Diameter D (mm)		Number of Holes
Over	Incl.	
-	180	4
180	250	6
250	315	6
315	400	6
400	500	6
500	630	8
630	800	8
800	1,000	8
1,000	1,250	8
1,250	1,600	8
1,600	2,000	8

Boundary Dimensions (mm)				Basic Load Ratings (N)		Limiting Speed (rpm)		Max Speed Rating ^{*1} (rpm)	Bearing Numbers	
d	D	B	r (min.)	C_r	C_{or}	Grease	Oil	Oil	Cylindrical Bore	Tapered Bore
40	80	23	1.1	113,000	99,500	6,700	8,500	12000	22208EAE4	22208EAKE4
	90	23	1.5	118,000	111,000	6,000	7,500	11000	21308EAE4	21308EAKE4
	90	33	1.5	170,000	153,000	5,300	6,700	9000	22308EAE4	22308EAKE4
45	85	23	1.1	118,000	111,000	6,000	7,500	11000	22209EAE4	22209EAKE4
	100	25	1.5	149,000	144,000	5,000	6,300	9000	21309EAE4	21309EAKE4
	100	36	1.5	207,000	195,000	4,500	5,600	8000	22309EAE4	22309EAKE4
50	90	23	1.1	124,000	119,000	5,600	7,100	9500	22210EAE4	22210EAKE4
	110	27	2.0	178,000	175,000	4,500	5,600	8000	21310EAE4	21310EAKE4
	110	40	2.0	246,000	234,000	4,300	5,300	7100	22310EAE4	22310EAKE4
55	100	25	1.5	149,000	144,000	5,300	6,700	9000	22211EAE4	22211EAKE4
	120	29	2.0	178,000	174,000	4,500	5,600	8000	21311EAE4	21311EAKE4
	120	43	2.0	292,000	292,000	3,800	4,800	6000	22311EAE4	22311EAKE4
60	110	28	1.5	178,000	174,000	4,800	6,000	8000	22212EAE4	22212EAKE4
	130	31	2.1	238,000	244,000	3,800	4,800	6700	21312EAE4	21312EAKE4
	130	46	2.1	340,000	340,000	3,600	4,500	5600	22312EAE4	22312EAKE4
65	120	31	1.5	221,000	230,000	4,300	5,300	7500	22213EAE4	22213EAKE4
	140	33	2.1	264,000	275,000	3,600	4,500	6000	21313EAE4	21313EAKE4
	140	48	2.1	375,000	380,000	3,200	4,000	5000	22313EAE4	22313EAKE4
70	125	31	1.5	225,000	232,000	4,000	5,300	7100	22214EAE4	22214EAKE4
	150	35	2.1	310,000	325,000	3,200	4,000	5600	21314EAE4	21314EAKE4
	150	51	2.1	425,000	435,000	3,000	3,800	4800	22314EAE4	22314EAKE4
75	130	31	1.5	238,000	244,000	4,000	5,000	6700	22215EAE4	22215EAKE4
	160	37	2.1	310,000	325,000	3,200	4,000	5600	21315EAE4	21315EAKE4
	160	55	2.1	485,000	505,000	2,800	3,600	4300	22315EAE4	22315EAKE4
80	140	33	2.0	264,000	275,000	3,600	4,500	6000	22216EAE4	22216EAKE4
	170	39	2.1	355,000	375,000	3,000	3,800	4800	21316EAE4	21316EAKE4
	170	58	2.1	540,000	565,000	2,600	3,400	3800	22316EAE4	22316EAKE4
85	150	36	2.0	310,000	325,000	3,400	4,300	5600	22217EAE4	22217EAKE4
	180	41	3.0	360,000	395,000	3,000	4,000	4800	21317EAE4	21317EAKE4
	180	60	3.0	600,000	630,000	2,400	3,200	3400	22317EAE4	22317EAKE4
90	160	40	2.0	360,000	395,000	3,200	4,000	5000	22218EAE4	22218EAKE4
	190	43	3.0	415,000	450,000	2,800	3,600	4500	21318EAE4	21318EAKE4
	190	64	3.0	665,000	705,000	2,400	3,000	3000	22318EAE4	22318EAKE4
95	170	43	2.1	415,000	450,000	3,000	3,800	4500	22219EAE4	22219EAKE4
	200	45	3.0	430,000	435,000	1,500	2,000	4800	21319EAE4	21319EAKE4
	200	67	3.0	735,000	780,000	2,200	2,800	3000	22319EAE4	22319EAKE4

Note: ^{*1} Limiting speed is applicable for general use. Please see Rolling Bearing Catalogue, Chapter: Limiting Speed. If max. speed rating is applied, please consult NSK.

Spherical Roller Bearings

Boundary Dimensions (mm)				Basic Load Ratings (N)		Limiting Speed (rpm)		Max Speed Rating ^{*1} (rpm)	Bearing Numbers	
d	D	B	r (min.)	C _r	C _{or}	Grease	oil	oil	Cylindrical Bore	Tapered Bore
100	180	46.0	2.1	455,000	490,000	2,800	3,600	4300	22220EAE4	22220EAKE4
	180	60.3	2.1	525,000	605,000	1,600	2,200	3800	23220CAME4	23220CAMKE4
	215	47.0	3.0	495,000	485,000	1,400	1,900	4500	21320CAME4	21320CAMKE4
	215	73.0	3.0	750,000	785,000	1,700	2,200	3400	22320CAME4 ^{*2}	22320CAMKE4 ^{*2}
110	180	56.0	2.0	480,000	630,000	1,600	2,000	4000	23122CAME4	23122CAMKE4
	180	69.0	2.0	575,000	750,000	1,600	2,000	3400	24122CAME4	24122CAMKE4
	200	53.0	2.1	605,000	645,000	2,600	3,200	3400	22222EAE4	22222EAKE4
	200	69.8	2.1	645,000	760,000	1,500	1,900	3400	23222CAME4	23222CAMKE4
	240	50.0	3.0	565,000	545,000	1,300	1,700	4300	21322CAME4	21322CAMKE4
240	80.0	3.0	925,000	980,000	1,500	1,900	3000	22322CAME4 ^{*2}	22322CAMKE4 ^{*2}	
120	180	46.0	2.0	395,000	525,000	1,800	2,200	4500	23024CAME4	23024CAMKE4
	180	60.0	2.0	480,000	680,000	1,500	2,000	3600	24024CAME4	24024CAMKE4
	200	62.0	2.0	580,000	720,000	1,400	1,800	3600	23124CAME4	23124CAMKE4
	200	80.0	2.0	695,000	905,000	1,400	1,800	3000	24124CAME4	24124CAMKE4
	215	58.0	2.1	685,000	765,000	2,400	3,000	3000	22224EAE4	22224EAKE4
	215	76.0	2.1	790,000	970,000	1,300	1,700	3000	23224CAME4	23224CAMKE4
130	260	86.0	3.0	1,060,000	1,120,000	1,400	1,700	2800	22324CAME4 ^{*2}	22324CAMKE4 ^{*2}
	200	52.0	2.0	500,000	655,000	1,700	2,000	3800	23026CAME4	23026CAMKE4
	200	69.0	2.0	620,000	865,000	1,400	1,800	3200	24026CAME4	24026CAMKE4
	210	64.0	2.0	630,000	825,000	1,300	1,700	3400	23126CAME4	23126CAMKE4
	210	80.0	2.0	735,000	1,010,000	1,300	1,700	2800	24126CAME4	24126CAMKE4
	230	64.0	3.0	820,000	940,000	2,200	2,600	2600	22226EAE4	22226EAKE4
	230	80.0	3.0	875,000	1,080,000	1,200	1,600	2800	23226CAME4	23226CAMKE4
	280	93.0	4.0	1,240,000	1,350,000	1,300	1,600	2600	22326CAME4	22326CAMKE4
140	210	53.0	2.0	525,000	715,000	1,600	1,900	3800	23028CAME4	23028CAMKE4
	210	69.0	2.0	635,000	905,000	1,300	1,700	3000	24028CAME4	24028CAMKE4
	225	68.0	2.1	725,000	945,000	1,200	1,600	3200	23128CAME4	23128CAMKE4
	225	85.0	2.1	835,000	1,160,000	1,200	1,600	2600	24128CAME4	24128CAMKE4
	250	68.0	3.0	835,000	945,000	1,400	1,700	3200	22228CAME4	22228CAMKE4
	250	88.0	3.0	1,040,000	1,300,000	1,100	1,500	2600	23228CAME4	23228CAMKE4
150	300	102.0	4.0	1,450,000	1,590,000	1,200	1,500	2400	22328CAME4	22328CAMKE4
	225	56.0	2.1	590,000	815,000	1,400	1,800	3600	23030CAME4	23030CAMKE4
	225	75.0	2.1	740,000	1,090,000	1,200	1,500	3000	24030CAME4	24030CAMKE4
	250	80.0	2.1	905,000	1,180,000	1,100	1,400	2800	23130CAME4	23130CAMKE4
	250	100.0	2.1	1,070,000	1,450,000	1,100	1,400	2400	24130CAME4	24130CAMKE4
	270	73.0	3.0	955,000	1,120,000	1,300	1,600	3000	22230CAME4	22230CAMKE4
	270	96.0	3.0	1,220,000	1,560,000	1,100	1,400	2400	23230CAME4	23230CAMKE4
160	320	108.0	4.0	1,530,000	1,690,000	1,100	1,400	2200	22330CAME4	22330CAMKE4
	220	45.0	2.0	450,000	675,000	1,400	1,800	3200	23932CAME4	23932CAMKE4
	240	60.0	2.1	675,000	955,000	1,300	1,700	3200	23032CAME4	23032CAMKE4
	240	80.0	2.1	845,000	1,260,000	1,100	1,400	2800	24032CAME4	24032CAMKE4
	270	86.0	2.1	1,070,000	1,400,000	1,000	1,300	2600	23132CAME4	23132CAMKE4
	270	109.0	2.1	1,240,000	1,670,000	1,000	1,300	2200	24132CAME4	24132CAMKE4
	290	80.0	3.0	1,140,000	1,320,000	1,200	1,500	2800	22232CAME4	22232CAMKE4
	290	104.0	3.0	1,370,000	1,770,000	1,000	1,300	2200	23232CAME4	23232CAMKE4
	340	114.0	4.0	1,700,000	1,900,000	1,100	1,300	2200	22332CAME4	22332CAMKE4
	170	230	45.0	2.0	440,000	660,000	1,400	1,800	3200	23934BCAME4
260		67.0	2.1	795,000	1,090,000	1,200	1,600	3000	23034CAME4	23034CAMKE4
260		90.0	2.1	1,030,000	1,520,000	1,000	1,300	2400	24034CAME4	24034CAMKE4
280		88.0	2.1	1,180,000	1,570,000	1,000	1,300	2600	23134CAME4	23134CAMKE4
280		109.0	2.1	1,280,000	1,770,000	1,000	1,300	2200	24134CAME4	24134CAMKE4
310		86.0	4.0	1,240,000	1,500,000	1,100	1,400	2600	22234CAME4	22234CAMKE4
310		110.0	4.0	1,500,000	1,910,000	900	1,200	2200	23234CAME4	23234CAMKE4
360		120.0	4.0	1,970,000	2,110,000	1,000	1,200	2000	22334CAME4	22334CAMKE4

Note: ^{*1} Limiting speed is applicable for general use. Please see Rolling Bearing Catalogue, Chapter: Limiting Speed. If max. speed rating is applied, please consult NSK.
^{*2} EA is also available. Load rating of EA is around 10% higher than CAM's, please consult NSK.

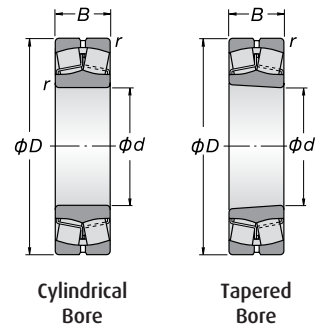
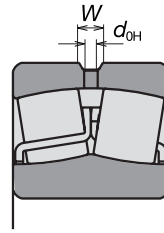

Table 1: Dimensions of Oil Groove and Holes

Nominal Width B		Oil Groove Width W	Hole Diameter d_{OH}
Over	Incl.		
18	30	5.0	2.5
30	40	6.0	3.0
40	50	7.0	4.0
50	65	8.0	5.0
65	80	10.0	6.0
80	100	12.0	8.0
100	120	15.0	10.0
120	160	20.0	12.0
160	200	25.0	15.0
200	250	30.0	20.0
250	315	35.0	20.0
315	400	40.0	25.0
400	-	40.0	25.0

Unit: mm

Table 2: Number of Oil Holes



Nominal Outer Ring Diameter D (mm)		Number of Holes
Over	Incl.	
-	180	4
180	250	6
250	315	6
315	400	6
400	500	6
500	630	8
630	800	8
800	1,000	8
1,000	1,250	8
1,250	1,600	8
1,600	2,000	8

Boundary Dimensions (mm)				Basic Load Ratings (N)		Limiting Speed (rpm)		Max Speed Rating ^{*1} (rpm)	Bearing Numbers		
d	D	B	r (min.)	C_r	C_{Or}	Grease	Oil	Oil	Cylindrical Bore	Tapered Bore	
180	250	52	2.0	590,000	890,000	1,200	1,600	3000	23936CAME4	23936CAMKE4	
	280	74	2.1	935,000	1,270,000	1,200	1,400	2800	23036CAME4	23036CAMKE4	
	280	100	2.1	1,210,000	1,750,000	950	1,200	2200	24036CAME4	24036CAMKE4	
	300	96	3.0	1,320,000	1,760,000	900	1,200	2200	23136CAME4	23136CAMKE4	
	300	118	3.0	1,490,000	2,040,000	900	1,200	2000	24136CAME4	24136CAMKE4	
	320	86	4.0	1,280,000	1,540,000	1,100	1,300	2600	22236CAME4	22236CAMKE4	
	320	112	4.0	1,620,000	2,110,000	850	1,100	2000	23236CAME4	23236CAMKE4	
	380	126	4.0	2,170,000	2,340,000	950	1,200	2000	22336CAME4	22336CAMKE4	
190	260	52	2.0	575,000	875,000	1,200	1,500	3000	23938CAME4	23938CAMKE4	
	290	75	2.1	970,000	1,350,000	1,100	1,400	2600	23038CAME4	23038CAMKE4	
	290	100	2.1	1,220,000	1,840,000	900	1,200	2200	24038CAME4	24038CAMKE4	
	320	104	3.0	1,480,000	2,020,000	850	1,100	2200	23138CAME4	23138CAMKE4	
	320	128	3.0	1,710,000	2,330,000	850	1,100	1900	24138CAME4	24138CAMKE4	
	340	92	4.0	1,420,000	1,730,000	1,000	1,200	2400	22238CAME4	22238CAMKE4	
	340	120	4.0	1,800,000	2,350,000	800	1,100	1900	23238CAME4	23238CAMKE4	
	400	132	5.0	2,370,000	2,590,000	900	1,100	1900	22338CAME4	22338CAMKE4	
200	280	60	2.1	710,000	1,060,000	1,100	1,400	2600	23940CAME4	23940CAMKE4	
	310	82	2.1	1,180,000	1,700,000	1,000	1,300	2400	23040CAME4	23040CAMKE4	
	310	109	2.1	1,420,000	2,120,000	850	1,100	2000	24040CAME4	24040CAMKE4	
	340	112	3.0	1,700,000	2,330,000	800	1,000	2000	23140CAME4	23140CAMKE4	
	340	140	3.0	1,960,000	2,660,000	800	1,000	1800	24140CAME4	24140CAMKE4	
	360	98	4.0	1,620,000	2,010,000	950	1,200	2200	22240CAME4	22240CAMKE4	
	360	128	4.0	2,070,000	2,750,000	750	1,000	1800	23240CAME4	23240CAMKE4	
	300	60	2.1	785,000	1,240,000	1,000	1,300	2600	23944CAME4	23944CAMKE4	
220	340	90	3.0	1,360,000	1,980,000	950	1,200	2200	23044CAME4	23044CAMKE4	
	340	118	3.0	1,640,000	2,490,000	750	1,000	1900	24044CAME4	24044CAMKE4	
	370	120	4.0	1,960,000	2,710,000	710	950	1800	23144CAME4	23144CAMKE4	
	370	150	4.0	2,250,000	3,200,000	710	950	1600	24144CAME4	24144CAMKE4	
	400	108	4.0	1,960,000	2,430,000	850	1,000	2000	22244CAME4	22244CAMKE4	
	400	144	4.0	2,520,000	3,400,000	670	900	1600	23244CAME4	23244CAMKE4	
	240	320	60	2.1	795,000	1,300,000	950	1,200	2600	23948CAME4	23948CAMKE4
		360	92	3.0	1,450,000	2,140,000	850	1,100	2200	23048CAME4	23048CAMKE4
360		118	3.0	1,730,000	2,730,000	710	950	1800	24048CAME4	24048CAMKE4	
400		128	4.0	2,230,000	3,100,000	670	850	1700	23148CAME4	23148CAMKE4	
400		160	4.0	2,660,000	3,800,000	670	850	1500	24148CAME4	24148CAMKE4	
260	360	75	2.1	1,170,000	1,870,000	850	1,000	2200	23952CAME4	23952CAMKE4	

Note: ^{*1} Limiting speed is applicable for general use. Please see Rolling Bearing Catalogue, Chapter: Limiting Speed. If max. speed rating is applied, please consult NSK.

NSK Sales Offices – Europe, Middle East and Africa

UK

NSK UK Ltd.
Northern Road, Newark
Nottinghamshire NG24 2JF
Tel. +44 (0) 1636 605123
Fax +44 (0) 1636 643276
info-uk@nsk.com

France

NSK France S.A.S.
Quartier de l'Europe
2, rue Georges Guynemer
78283 Guyancourt Cedex
Tel. +33 (0) 1 30573939
Fax +33 (0) 1 30570001
info-fr@nsk.com

Germany, Austria, Switzerland, Benelux, Nordic

NSK Deutschland GmbH
Harkortstraße 15
40880 Ratingen
Tel. +49 (0) 2102 4810
Fax +49 (0) 2102 4812290
info-de@nsk.com

Italy

NSK Italia S.p.A.
Via Garibaldi, 215
20024 Garbagnate
Milanese (MI)
Tel. +39 02 995 191
Fax +39 02 990 25 778
info-it@nsk.com

Middle East

NSK Bearings Gulf Trading Co.
JAFZA View 19, Floor 24 Office 2/3
Jebel Ali Downtown,
PO Box 262163
Dubai, UAE
Tel. +971 (0) 4 804 8205
Fax +971 (0) 4 884 7227
info-me@nsk.com

Poland & CEE

NSK Polska Sp. z o.o.
Warsaw Branch
Ul. Migdałowa 4/73
02-796 Warszawa
Tel. +48 22 645 15 25
Fax +48 22 645 15 29
info-pl@nsk.com

Russia

NSK Polska Sp. z o.o.
Russian Branch
Office 1 703, Bldg 29,
18th Line of Vasilievskiy Ostrov,
Saint-Petersburg, 199178
Tel. +7 812 3325071
Fax +7 812 3325072
info-ru@nsk.com

South Africa

NSK South Africa (Pty) Ltd.
27 Galaxy Avenue
Linbro Business Park
Sandton 2146
Tel. +27 (011) 458 3600
Fax +27 (011) 458 3608
nsk-sa@nsk.com

Spain

NSK Spain, S.A.
C/ Tarragona, 161 Cuerpo Bajo
2ª Planta, 08014 Barcelona
Tel. +34 93 2892763
Fax +34 93 4335776
info-es@nsk.com

Turkey

NSK Rulmanları Orta Doğu Tic. Ltd. Şti
19 Mayıs Mah. Atatürk Cad.
Ulya Engin İş Merkezi No: 68/3 Kat. 6
P.K.: 34736 - Kozyatağı - İstanbul
Tel. +90 216 4777111
Fax +90 216 4777174
turkey@nsk.com

Please also visit our website: www.nskeurope.com
Global NSK: www.nsk.com

