

+ ROLLING BEARINGS



PLUMMER BLOCKS

STANDARD TYPE PLUMMER BLOCKS	B302
LARGE PLUMMER BLOCKS	B308
DUSTPROOF PLUMMER BLOCKS	B312
STEPPED-SHAFT TYPE PLUMMER BLOCKS	B314

DESIGN, TYPES AND FEATURES

There are numerous types and sizes of plummer blocks. In this catalog, only the types marked by are shown.



- SN 5
- SN 6
- SN 30
- SN 31
- SN 2
- SN 3
- SN 2C
- SN 3C

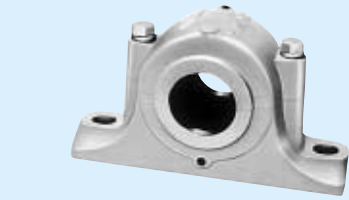

These are the most common type. Models SN30 and SN31 are for medium loads.

For types SN2C and SN3C, the bore diameters on the two sides are different.

- SN 5B
- SN 6B
- SN 30B
- SN 31B
- SN 2B
- SN 3B
- SN 2BC
- SN 3BC



These have the same dimensions as those of types SN5 and SN6. To increase the bearing box strength, no material is removed from the top or bottom of the base, so mounting holes can be drilled anywhere.

- SG 5



Dustproof plummer blocks have a combination of oil seals, labyrinth seals, and oil groove seals, therefore, they are suitable for environments with much dust and other foreign matter.

- SD 30S
- SD 31S
- SD 5
- SD 6
- SD 2
- SD 3
- SD 2C
- SD 3C

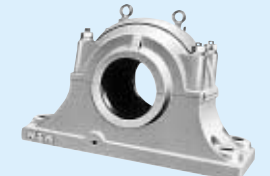

These are large and made for heavy loads. The standard ones have double seals and four mounting bolt holes. For types SD2C and SD3C, the bore diameters on the two sides are different.

- SD31TS
- SD32TS

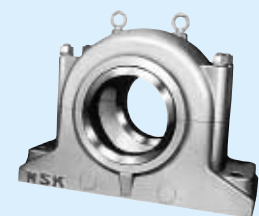

These are provided with labyrinth seals, so they are suitable for high speed applications.

- V · C



Single-piece plummer blocks (integrated type roller bearing unit) have higher rigidity and precision than split type plummer blocks.

SN 5, SN 6 Types
Shaft Diameter 20 – 55 mm

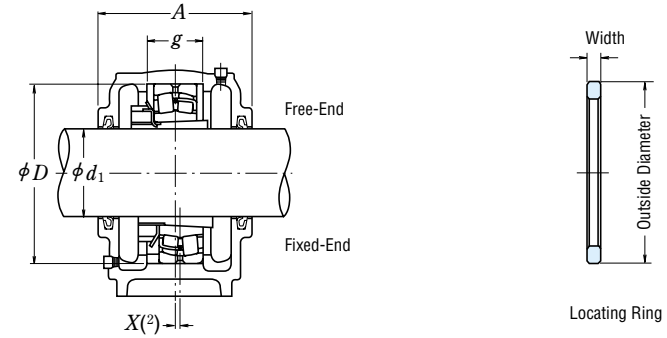
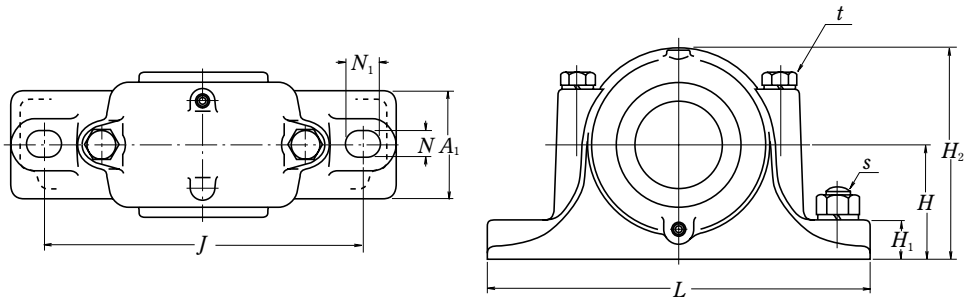

Shaft Diameter (mm) d_1	Plummer Block Bearing Box Numbers (1)	Dimensions (mm)											Mass (kg) approx		
		D_{H8}	H_{h13}	J	N	N_1	A	L	A_1	H_1	H_2	g_{H13}		$t_{nominal}$	$s_{nominal}$
20	SN 505	52	40	130	15	20	67	165	46	22	75	25	M 8	M 12	1.1
	SN 605	62	50	150	15	20	80	185	52	22	90	34	M 8	M 12	1.6
25	SN 506	62	50	150	15	20	77	185	52	22	90	30	M 8	M 12	1.7
	SN 606	72	50	150	15	20	82	185	52	22	95	37	M 10	M 12	1.8
30	SN 507	72	50	150	15	20	82	185	52	22	95	33	M 10	M 12	1.9
	SN 607	80	60	170	15	20	90	205	60	25	110	41	M 10	M 12	2.6
35	SN 508	80	60	170	15	20	85	205	60	25	110	33	M 10	M 12	2.6
	SN 608	90	60	170	15	20	95	205	60	25	115	43	M 10	M 12	2.9
40	SN 509	85	60	170	15	20	85	205	60	25	112	31	M 10	M 12	2.8
	SN 609	100	70	210	18	23	105	255	70	28	130	46	M 12	M 16	4.1
45	SN 510	90	60	170	15	20	90	205	60	25	115	33	M 10	M 12	3.0
	SN 610	110	70	210	18	23	115	255	70	30	135	50	M 12	M 16	4.7
50	SN 511	100	70	210	18	23	95	255	70	28	130	33	M 12	M 16	4.5
	SN 611	120	80	230	18	23	120	275	80	30	150	53	M 12	M 16	5.8
55	SN 512	110	70	210	18	23	105	255	70	30	135	38	M 12	M 16	5.0
	SN 612	130	80	230	18	23	125	280	80	30	155	56	M 12	M 16	6.5

Note (1) Including oil seal.

To place an order for a complete unit, please specify, "Plummer block bearing box+bearing+adapter+locating ring".

Remarks Threads for plugs are R 1/8.

Applicable Parts							Oil Seals (2)
Self-Aligning Ball Bearing Numbers	Basic Dynamic Load Ratings C_r (N)	Spherical Roller Bearing Numbers	Basic Dynamic Load Ratings C_r (N)	Adapter Numbers	Locating Rings Nominal (Outside x Width)	Q'ty	
1205 K	12 200	—	—	H 205X	SR 52x 5	2	GS 5
2205 K	12 400	22205 CKE4	37 500	H 305X	SR 52x 7	1	
1305 K	18 200	21305 CDKE4	43 000	H 305X	SR 62x 8.5	2	GS 5
2305 K	24 900	—	—	H 2305X	SR 62x 10	1	
1206 K	15 800	—	—	H 206X	SR 62x 7	2	GS 6
2206 K	15 300	22206 CKE4	50 000	H 306X	SR 62x 10	1	
1306 K	21 400	21306 CDKE4	55 000	H 306X	SR 72x 9	2	GS 6
2306 K	32 000	—	—	H 2306X	SR 72x 10	1	
1207 K	15 900	—	—	H 207X	SR 72x 8	2	GS 7
2207 K	21 700	22207 CKE4	69 000	H 307X	SR 72x 10	1	
1307 K	25 300	21307 CDKE4	71 500	H 307X	SR 80x 10	2	GS 7
2307 K	40 000	—	—	H 2307X	SR 80x 10	1	
1208 K	19 300	—	—	H 208X	SR 80x 7.5	2	GS 8
2208 K	22 400	22208 EAKE4	90 500	H 308X	SR 80x 10	1	
1308 K	29 800	21308 EAKE4	94 500	H 308X	SR 90x 10	2	GS 8
2308 K	45 500	22308 EAKE4	136 000	H 2308X	SR 90x 10	1	
1209 K	22 000	—	—	H 209X	SR 85x 6	2	GS 9
2209 K	23 300	22209 EAKE4	94 500	H 309X	SR 85x 8	1	
1309 K	38 500	21309 EAKE4	119 000	H 309X	SR 100x 10.5	2	GS 9
2309 K	55 000	22309 EAKE4	166 000	H 2309X	SR 100x 10	1	
1210 K	22 800	—	—	H 210X	SR 90x 6.5	2	GS10
2210 K	23 400	22210 EAKE4	99 000	H 310X	SR 90x 10	1	
1310 K	43 500	21310 EAKE4	142 000	H 310X	SR 110x 11.5	2	GS10
2310 K	65 000	22310 EAKE4	197 000	H 2310X	SR 110x 10	1	
1211 K	26 900	—	—	H 211X	SR 100x 6	2	GS11
2211 K	26 700	22211 EAKE4	119 000	H 311X	SR 100x 8	1	
1311 K	51 500	21311 EAKE4	142 000	H 311X	SR 120x 12	2	GS11
2311 K	76 500	22311 EAKE4	234 000	H 2311X	SR 120x 10	1	
1212 K	30 500	—	—	H 212X	SR 110x 8	2	GS12
2212 K	34 000	22212 EAKE4	142 000	H 312X	SR 110x 10	1	
1312 K	57 500	21312 EAKE4	190 000	H 312X	SR 130x 12.5	2	GS12
2312 K	88 500	22312 EAKE4	271 000	H 2312X	SR 130x 10	1	

Notes (2) The X dimension indicates the offset of the bearing center from the center of the plummer block bearing box. When one locating ring is used, it is 1/2 of the locating ring width, and when two rings are used, it becomes 0.

(3) Applicable to the ZF Type with the same number.

SN 31, SN 5, SN 6 Types
Shaft Diameter 60 – 100 mm

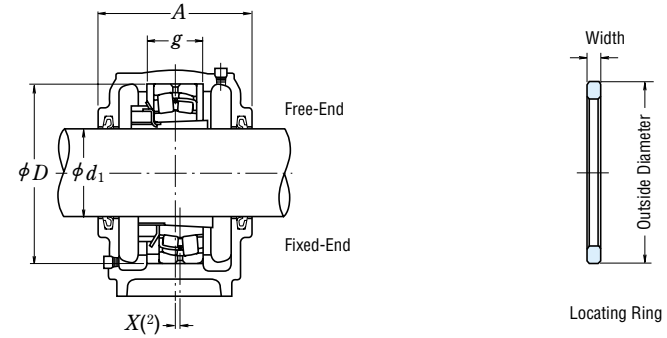
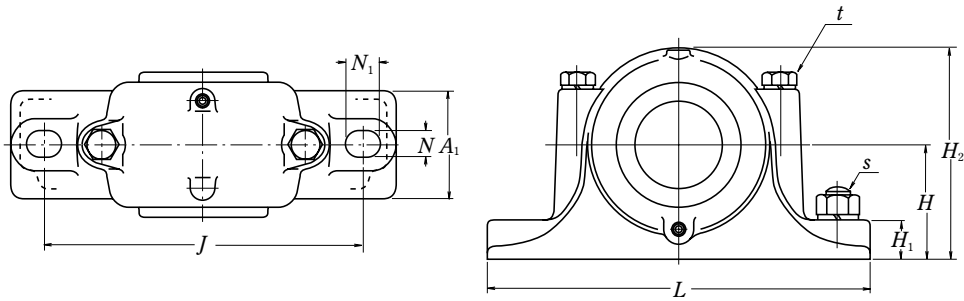

Shaft Diameter (mm) d_1	Plummer Block Bearing Box Numbers ⁽¹⁾	Dimensions (mm)												Mass (kg) approx	
		D H8	H h13	J	N	N ₁	A	L	A ₁	H ₁	H ₂	g H13	t nominal		s nominal
60	SN 513	120	80	230	18	23	110	275	80	30	150	43	M12	M16	5.6
	SN 613	140	95	260	22	27	130	315	90	32	175	58	M16	M20	8.7
65	SN 515	130	80	230	18	23	115	280	80	30	155	41	M12	M16	7.0
	SN 615	160	100	290	22	27	140	345	100	35	195	65	M16	M20	11.3
70	SN 516	140	95	260	22	27	120	315	90	32	175	43	M16	M20	9.0
	SN 616	170	112	290	22	27	145	345	100	35	212	68	M16	M20	12.6
75	SN 517	150	95	260	22	27	125	320	90	32	185	46	M16	M20	10
	SN 617	180	112	320	26	32	155	380	110	40	218	70	M20	M24	15
80	SN 518	160	100	290	22	27	145	345	100	35	195	62.4	M16	M20	13
	SN 618	190	112	320	26	32	160	380	110	40	225	74	M20	M24	19
85	SN 519	170	112	290	22	27	140	345	100	35	210	53	M16	M20	15
	SN 619	200	125	350	26	32	170	410	120	45	245	77	M20	M24	22
90	SN 520	180	112	320	26	32	160	380	110	40	218	70.3	M20	M24	18.5
	SN 620	215	140	350	26	32	175	410	120	45	270	83	M20	M24	25
100	SN 3122	180	112	320	26	32	155	380	110	40	218	66	M20	M24	18
	SN 522	200	125	350	26	32	175	410	120	45	240	80	M20	M24	20
	SN 622	240	150	390	28	36	190	450	130	50	300	90	M24	M24	32

Note ⁽¹⁾ Including oil seal.

To place an order for a complete unit, please specify, "Plummer block bearing box+bearing+adapter+locating ring".

Remarks 1. The threads for plugs are R 1/8 for SN 616 and SN 519 or under and R 1/4 for SN 617, SN 520, SN 3122, and over.
2. SN 620 and SN 622 are provided with eye bolts.

Applicable Parts								Oil Seals ⁽²⁾
Self-Aligning Ball Bearing Numbers	Basic Dynamic Load Ratings C _r (N)	Spherical Roller Bearing Numbers	Basic Dynamic Load Ratings C _r (N)	Adapter Numbers	Locating Rings Nominal (Outside Dia. xWidth)	Q'ty		
1213 K	31 000	—	—	H 213X	SR 120×10	2	GS13	
2213 K	43 500	22213 EAKE4	177 000	H 313X	SR 120×12	1		
1313 K	62 500	21313 EAKE4	212 000	H 313X	SR 140×12.5	2	GS13	
2313 K	97 000	22313 EAKE4	300 000	H 2313X	SR 140×10	1		
1215 K	39 000	—	—	H 215X	SR 130×8	2	GS15	
2215 K	44 500	22215 EAKE4	190 000	H 315X	SR 130×10	1		
1315 K	80 000	21315 EAKE4	250 000	H 315X	SR 160×14	2	GS15	
2315 K	125 000	22315 EAKE4	390 000	H 2315X	SR 160×10	1		
1216 K	40 000	—	—	H 216X	SR 140×8.5	2	GS16	
2216 K	49 000	22216 EAKE4	212 000	H 316X	SR 140×10	1		
1316 K	89 000	21316 EAKE4	284 000	H 316X	SR 170×14.5	2	GS16	
2316 K	130 000	22316 EAKE4	435 000	H 2316X	SR 170×10	1		
1217 K	49 500	—	—	H 217X	SR 150×9	2	GS17	
2217 K	58 500	22217 EAKE4	250 000	H 317X	SR 150×10	1		
1317 K	98 500	21317 EAKE4	289 000	H 317X	SR 180×14.5	2	GS17	
2317 K	142 000	22317 EAKE4	480 000	H 2317X	SR 180×10	1		
1218 K	57 500	—	—	H 218X	SR 160×16.2	2	GS18	
2218 K	70 500	22218 EAKE4	289 000	H 318X	SR 160×11.2	2		
—	—	23218 CKE4	340 000	H 2318X	SR 160×10	1		
1318 K	117 000	21318 EAKE4	330 000	H 318X	SR 190×15.5	2	GS18	
2318 K	154 000	22318 EAKE4	535 000	H 2318X	SR 190×10	1		
1219 K	64 000	—	—	H 219X	SR 170×10.5	2	GS19	
2219 K	84 000	22219 EAKE4	330 000	H 319X	SR 170×10	1		
1319 K	129 000	21319 CKE4	345 000	H 319X	SR 200×16	2	GS19	
2319 K	161 000	22319 EAKE4	590 000	H 2319X	SR 200×10	1		
1220 K	69 500	—	—	H 220X	SR 180×18.1	2	GS20	
2220 K	94 500	22220 EAKE4	365 000	H 320X	SR 180×12.1	2		
—	—	23220 CKE4	420 000	H 2320X	SR 180×10	1		
1320 K	140 000	21320 CKE4	395 000	H 320X	SR 215×18	2	GS20	
2320 K	187 000	22320 EAKE4	690 000	H 2320X	SR 215×10	1		
—	—	23122 CKE4	385 000	H 3122X	SR 180×10	1	GS22	
1222 K	87 000	—	—	H 222X	SR 200×21	2	GS22	
2222 K	122 000	22222 EAKE4	485 000	H 322X	SR 200×13.5	2		
—	—	23222 CKE4	515 000	H 2322X	SR 200×10	1		
1322 K	161 000	21322 CAKE4	450 000	H 322X	SR 240×20	2	GS22	
2322 K	211 000	22322 EAKE4	825 000	H 2322X	SR 240×10	1		

Notes ⁽²⁾ The X dimension indicates the offset of the bearing center from the center of the plummer block bearing box. When one locating ring is used, it is 1/2 of the locating ring width, and when two rings are used, it becomes 0.

⁽³⁾ Applicable to the ZF Type with the same number.

STANDARD TYPE PLUMMER BLOCKS

SN 30, SN 31, SN 5, SN 6 Types
Shaft Diameter 110 – 140 mm

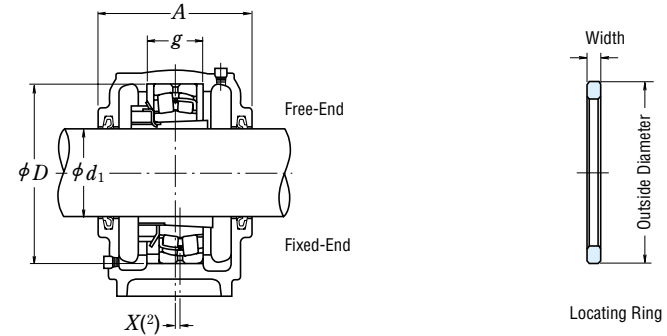
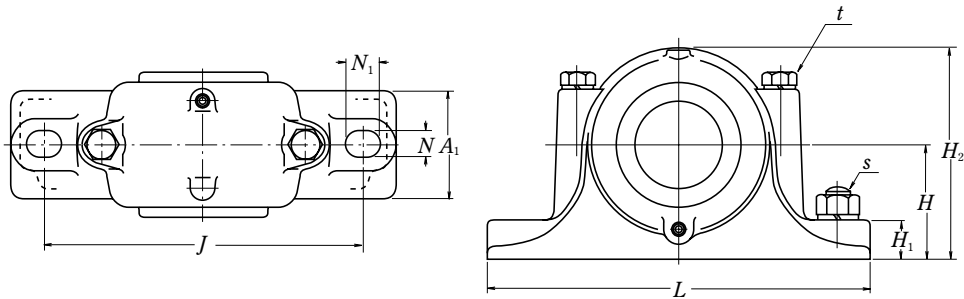

Shaft Diameter (mm) d_1	Plummer Block Bearing Box Numbers ⁽¹⁾	Dimensions (mm)											Mass (kg) approx			
		D_{H8}	H_{h13}	J	N	N_1	A	L	A_1	H_1	H_2	g_{H13}		$t_{nominal}$	$s_{nominal}$	
110	SN 3024	180	112	320	26	32	150	380	110	40	218	56	M20	M24	16	
	SN 3124	200	125	350	26	32	165	410	120	45	245	72	M20	M24	20	
	SN 524	215	140	350	26	32	185	410	120	45	270	86	M20	M24	24.5	
	SN 624	260	160	450	33	42	200	530	160	60	320	96	M24	M30	48	
115	SN 3026	200	125	350	26	32	160	410	120	45	240	62	M20	M24	19	
	SN 3126	210	140	350	26	32	170	410	120	45	270	74	M20	M24	26	
	SN 526	230	150	380	28	36	190	445	130	50	290	90	M24	M24	30	
	SN 626	280	170	470	33	42	210	550	160	60	340	103	M24	M30	56	
125	SN 3028	210	140	350	26	32	170	410	120	45	270	63	M20	M24	25	
	SN 3128	225	150	380	28	36	180	445	130	50	290	78	M24	M24	32	
	SN 528	250	150	420	33	42	205	500	150	50	305	98	M24	M30	38	
		SN 628	300	180	520	35	45	235	610	170	65	365	112	M30	M30	72
		SN 3030	225	150	380	28	36	175	445	130	50	290	66	M24	M24	29
135	SN 3130	250	150	420	33	42	200	500	150	50	305	90	M24	M30	38	
	SN 530	270	160	450	33	42	220	530	160	60	325	106	M24	M30	46	
	SN 630	320	190	560	35	45	245	650	180	65	385	118	M30	M30	98	
140	SN 3032	240	150	390	28	36	190	450	130	50	300	70	M24	M24	32	
	SN 3132	270	160	450	33	42	215	530	160	60	325	96	M24	M30	48	
	SN 532	290	170	470	33	42	235	550	160	60	345	114	M24	M30	50	
		SN 632	340	200	580	42	50	255	680	190	70	405	124	M30	M36	115

Applicable Parts							Oil Seals ⁽²⁾
Self-Aligning Ball Bearing Numbers	Basic Dynamic Load Ratings C_r (N)	Spherical Roller Bearing Numbers	Basic Dynamic Load Ratings C_r (N)	Adapter Numbers	Locating Rings Nominal (Outside Dia. x Width)	Q'ty	
—	—	23024 CDKE4	315 000	H 3024	SR 180x10	1	GS24
—	—	23124 CKE4	465 000	H 3124	SR 200x10	1	GS24
—	—	22224 EAKE4	550 000	H 3124	SR 215x14	2	GS24
—	—	23224 CKE4	630 000	H 2324	SR 215x10	1	GS24
—	—	22324 EAKE4	955 000	H 2324	SR 260x10	1	GS24
—	—	23026 CDKE4	400 000	H 3026	SR 200x10	1	GS26
—	—	23126 CKE4	505 000	H 3126	SR 210x10	1	GS26
—	—	22226 EAKE4	655 000	H 3126	SR 230x13	2	GS26
—	—	23226 CKE4	700 000	H 2326	SR 230x10	1	GS26
—	—	22326 EAKE4	995 000	H 2326	SR 280x10	1	GS26
—	—	23028 CDKE4	420 000	H 3028	SR 210x10	1	GS28
—	—	23128 CKE4	580 000	H 3128	SR 225x10	1	GS28
—	—	22228 CDKE4	645 000	H 3128	SR 250x15	2	GS28
—	—	23228 CKE4	835 000	H 2328	SR 250x10	1	GS28
—	—	22328 EAKE4	1 160 000	H 2328	SR 300x10	1	GS28
—	—	23030 CDKE4	470 000	H 3030	SR 225x10	1	GS30
—	—	23130 CKE4	725 000	H 3130	SR 250x10	1	GS30
—	—	22230 CDKE4	765 000	H 3130	SR 270x16.5	2	GS30
—	—	23230 CKE4	975 000	H 2330	SR 270x10	1	GS30
—	—	22330 EAKE4	1 220 000	H 2330	SR 320x10	1	GS30
—	—	23032 CDKE4	540 000	H 3032	SR 240x10	1	GS32
—	—	23132 CKE4	855 000	H 3132	SR 270x10	1	GS32
—	—	22232 CDKE4	910 000	H 3132	SR 290x17	2	GS32
—	—	23232 CKE4	1 100 000	H 2332	SR 290x10	1	GS32
—	—	22332 EAKE4	1 360 000	H 2332	SR 340x10	1	GS32

Note ⁽¹⁾ Including oil seal.

To place an order for a complete unit, please specify, "Plummer block bearing box+bearing+adapter+locating ring".

Remarks 1. The threads for plugs are R 1/4.

2. The bearing boxes for SN 524, SN 624, SN 3126, SN 3028, and over are provided with eye bolts.

Notes ⁽²⁾ The X dimension indicates the offset of the bearing center from the center of the plummer block bearing box. When one locating ring is used, it is 1/2 of the locating ring width, and when two rings are used, it becomes 0.

⁽³⁾ Applicable to the ZF Type with the same number.

LARGE-SIZE PLUMMER BLOCKS

SD 30 S, SD 31 S, SD 5, SD 6 Types
Shaft Diameter 150 – 260 mm

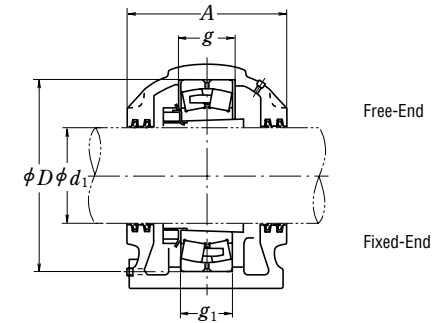
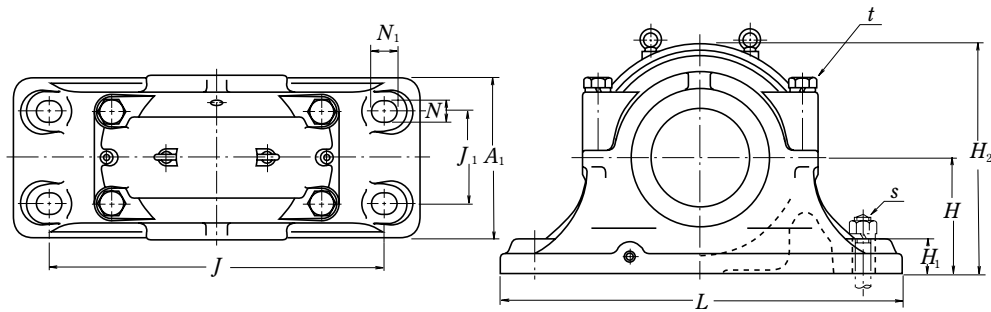

Shaft Diameter (mm) d_1	Plummer Block Bearing Box Numbers ⁽¹⁾		Dimensions (mm)										
	Free-End	Fixed-End	D_{H8}	H_{h13}	J	N	N_1	A	L	A_1	H_1	H_2	J_1
150	SD 3034 S	SD 3034 SG	260	160	450	36	46	230	540	200	50	315	110
	SD 3134 S	SD 3134 SG	280	170	470	36	46	250	560	220	50	335	120
	SD 534	SD 534 G	310	180	510	36	46	270	620	250	60	360	140
	SD 634	SD 634 G	360	210	610	36	46	300	740	290	65	420	170
160	SD 3036 S	SD 3036 SG	280	170	470	36	46	250	560	220	50	335	120
	SD 3136 S	SD 3136 SG	300	180	520	36	46	270	630	250	55	355	140
	SD 536	SD 536 G	320	190	540	36	46	280	650	260	60	380	150
	SD 636	SD 636 G	380	225	640	43	59	320	780	310	70	450	180
170	SD 3038 S	SD 3038 SG	290	170	470	36	46	250	560	220	50	340	120
	SD 3138 S	SD 3138 SG	320	190	560	36	46	290	680	270	55	385	140
	SD 538	SD 538 G	340	200	570	36	46	290	700	280	65	400	160
	SD 638	SD 638 G	400	240	680	43	59	330	820	320	70	475	190
180	SD 3040 S	SD 3040 SG	310	180	510	36	46	270	620	250	60	360	140
	SD 3140 S	SD 3140 SG	340	200	570	36	46	310	700	280	65	400	160
	SD 540	SD 540 G	360	210	610	36	46	300	740	290	65	420	170
	SD 640	SD 640 G	420	250	710	43	59	350	860	340	85	500	200
200	SD 3044 S	SD 3044 SG	340	200	570	36	46	290	700	280	65	400	160
	SD 3144 S	SD 3144 SG	370	225	640	43	59	320	780	310	70	445	180
	SD 544	SD 544 G	400	240	680	43	59	330	820	320	70	475	190
	SD 644	SD 644 G	460	280	770	43	59	360	920	350	85	550	210
220	SD 3048 S	SD 3048 SG	360	210	610	36	46	300	740	290	65	420	170
	SD 3148 S	SD 3148 SG	400	240	680	43	59	330	820	320	70	475	190
	SD 548	SD 548 G	440	260	740	43	59	340	880	330	85	515	200
	SD 648	SD 648 G	500	300	830	50	67	390	990	380	100	590	230
240	SD 3052 S	SD 3052 SG	400	240	680	43	59	340	820	320	70	475	190
	SD 3152 S	SD 3152 SG	440	260	740	43	59	360	880	350	85	515	200
	SD 552	SD 552 G	480	280	790	43	59	370	940	360	85	560	210
	SD 652	SD 652 G	540	325	890	50	67	410	1 060	400	100	640	250
260	SD 3056 S	SD 3056 SG	420	250	710	43	59	350	860	340	85	500	200
	SD 3156 S	SD 3156 SG	460	280	770	43	59	360	920	350	85	550	210
	SD 556	SD 556 G	500	300	830	50	67	390	990	380	100	590	230
	SD 656	SD 656 G	580	355	930	57	77	440	1 110	430	110	690	270

g_{H13}	g_1_{H13}	$t_{nominal}$	$s_{nominal}$	Mass (kg) approx	Applicable Parts			Oil Seals ⁽²⁾
					Spherical Roller Bearing Numbers	Basic Dynamic Load Ratings C_r (N)	Adapter Numbers	
77	67	M 24	M 30	70	23034 CDKE4	640 000	H 3034	GS 34
98	88	M 24	M 30	75	23134 CKE4	940 000	H 3134	GS 34
96	86	M 24	M 30	100	22234 CDKE4	990 000	H 3134	GS 34
130	120	M 30	M 30	160	22334 CAKE4	1 580 000	H 2334	GS 34
84	74	M 24	M 30	79	23036 CDKE4	750 000	H 3036	GS 36
106	96	M 24	M 30	94	23136 CKE4	1 050 000	H 3136	GS 36
96	86	M 24	M 30	110	22236 CDKE4	1 020 000	H 3136	GS 36
136	126	M 30	M 36	195	22336 CAKE4	1 740 000	H 2336	GS 36
85	75	M 24	M 30	87	23038 CAKE4	775 000	H 3038	GS 38
114	104	M 24	M 30	110	23138 CKE4	1 190 000	H 3138	GS 38
102	92	M 30	M 30	130	22238 CAKE4	1 140 000	H 3138	GS 38
142	132	M 30	M 36	210	22338 CAKE4	1 890 000	H 2338	GS 38
92	82	M 24	M 30	100	23040 CAKE4	940 000	H 3040	GS 40
122	112	M 30	M 30	130	23140 CKE4	1 360 000	H 3140	GS 40
108	98	M 30	M 30	155	22240 CAKE4	1 300 000	H 3140	GS 40
148	138	M 36	M 36	240	22340 CAKE4	2 000 000	H 2340	GS 40
100	90	M 30	M 30	130	23044 CAKE4	1 090 000	H 3044	GS 44
130	120	M 30	M 36	180	23144 CKE4	1 570 000	H 3144	GS 44
118	108	M 30	M 36	205	22244 CAKE4	1 570 000	H 3144	GS 44
155	145	M 36	M 36	315	22344 CAKE4	2 350 000	H 2344	GS 44
102	92	M 30	M 30	160	23048 CAKE4	1 160 000	H 3048	GS 48
138	128	M 30	M 36	210	23148 CKE4	1 790 000	H 3148	GS 48
130	120	M 36	M 36	240	22248 CAKE4	1 870 000	H 3148	GS 48
165	155	M 36	M 42	405	22348 CAKE4	2 600 000	H 2348	GS 48
114	104	M 30	M 36	210	23052 CAKE4	1 430 000	H 3052	GS 52
154	144	M 36	M 36	240	23152 CAKE4	2 160 000	H 3152	GS 52
140	130	M 36	M 36	315	22252 CAKE4	2 180 000	H 3152	GS 52
175	165	M 36	M 42	480	22352 CAKE4	3 100 000	H 2352	GS 52
116	106	M 36	M 36	240	23056 CAKE4	1 540 000	H 3056	GS 56
156	146	M 36	M 36	315	23156 CAKE4	2 230 000	H 3156	GS 56
140	130	M 36	M 42	390	22256 CAKE4	2 280 000	H 3156	GS 56
185	175	M 42	M 48	610	22356 CAKE4	3 500 000	H 2356	GS 56

Note ⁽¹⁾ Including oil seal.

To place an order for a complete unit, please specify, "Plummer block bearing box+bearing+adapter".

- Remarks
- The threads for oil replenishing hole plugs are R 1/4 and those for drain plugs are R 3/8.
 - The plummer block bearing boxes listed above are provided with eye bolts.

Note ⁽²⁾ Applicable to the ZF Type with the same number.

LARGE-SIZE PLUMMER BLOCKS

SD 30 S, SD 31 S, SD 5 Types
Shaft Diameter 280 – 450 mm

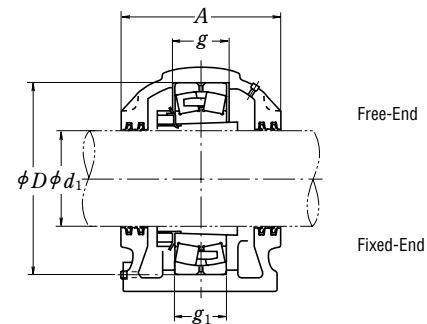
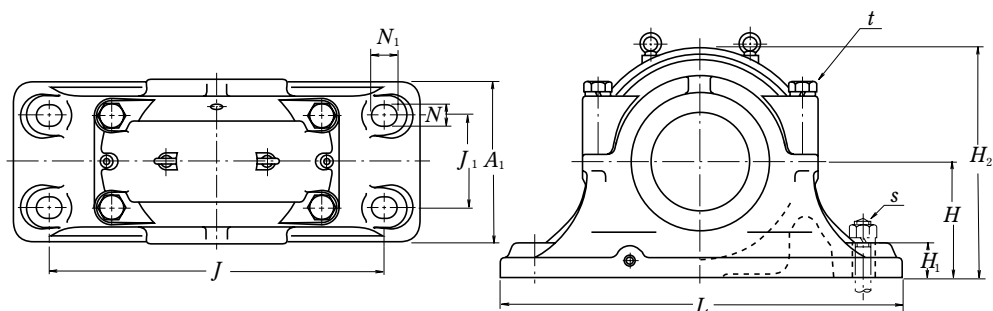

Shaft Diameter (mm) d_1	Plummer Block Bearing Box Numbers ⁽¹⁾		Dimensions (mm)										
	Free-End	Fixed-End	D	H	J	N	N_1	A	L	A_1	H_1	H_2	J_1
			H8	h13									
280	SD 3060 S	SD 3060 SG	460	280	770	43	59	360	920	350	85	550	210
	SD 3160 S	SD 3160 SG	500	300	830	50	67	390	990	380	100	590	230
	SD 560	SD 560 G	540	325	890	50	67	410	1 060	400	100	640	250
300	SD 3064 S	SD 3064 SG	480	280	790	43	59	380	940	360	85	560	210
	SD 3164 S	SD 3164 SG	540	325	890	50	67	430	1 060	400	100	640	250
	SD 564	SD 564 G	580	355	930	57	77	440	1 110	430	110	690	270
320	SD 3068 S	SD 3068 SG	520	310	860	50	67	400	1 020	370	100	615	230
	SD 3168 S	SD 3168 SG	580	355	930	57	77	470	1 110	450	110	690	270
340	SD 3072 S	SD 3072 SG	540	325	890	50	67	410	1 060	390	100	640	250
	SD 3172 S	SD 3172 SG	600	365	960	57	77	470	1 140	460	120	710	310
360	SD 3076 S	SD 3076 SG	560	340	900	50	67	410	1 080	390	100	665	260
	SD 3176 S	SD 3176 SG	620	375	980	57	77	500	1 160	490	120	735	320
380	SD 3080 S	SD 3080 SG	600	365	960	57	77	430	1 140	420	120	710	270
	SD 3180 S	SD 3180 SG	650	390	1 040	57	77	520	1 220	510	125	765	340
400	SD 3084 S	SD 3084 SG	620	375	980	57	77	430	1 160	420	120	735	270
	SD 3184 S	SD 3184 SG	700	420	1 070	57	77	560	1 250	550	135	830	380
410	SD 3088 S	SD 3088 SG	650	390	1 040	57	77	460	1 220	450	125	765	280
430	SD 3092 S	SD 3092 SG	680	405	1 040	57	77	470	1 220	460	130	790	310
450	SD 3096 S	SD 3096 SG	700	415	1 100	57	77	485	1 280	470	130	820	320

g H13	g_1 H13	t nominal	s nominal	Mass (kg) approx	Applicable Parts			Oil Seals ⁽²⁾
					Spherical Roller Bearing Numbers	Basic Dynamic Load Ratings C_r (N)	Adapter Numbers	
128	118	M 36	M 36	300	23060 CAKE4	1 920 000	H 3060	GS 60
170	160	M 36	M 42	405	23160 CAKE4	2 670 000	H 3160	GS 60
150	140	M 36	M 42	465	22260 CAKE4	2 610 000	H 3160	GS 60
131	121	M 36	M 36	320	23064 CAKE4	1 960 000	H 3064	GS 64
186	176	M 36	M 42	480	23164 CAKE4	3 050 000	H 3164	GS 64
160	150	M 42	M 48	595	22264 CAKE4	2 990 000	H 3164	GS 64
143	133	M 36	M 42	410	23068 CAKE4	2 280 000	H 3068	GS 68
200	190	M 42	M 48	650	23168 CAKE4	3 600 000	H 3168	GS 68
144	134	M 36	M 42	465	23072 CAKE4	2 390 000	H 3072	GS 72
202	192	M 42	M 48	700	23172 CAKE4	3 800 000	H 3172	GS 72
145	135	M 36	M 42	480	23076 CAKE4	2 500 000	H 3076	GS 76
204	194	M 42	M 48	940	23176 CAKE4	4 000 000	H 3176	GS 76
158	148	M 42	M 48	690	23080 CAKE4	2 970 000	H 3080	GS 80
210	200	M 42	M 48	1 040	23180 CAKE4	4 150 000	H 3180	GS 80
160	150	M 42	M 48	770	23084 CAKE4	2 910 000	H 3084	GS 84
234	224	M 48	M 48	1 150	23184 CAKE4	5 000 000	H 3184	GS 84
167	157	M 42	M 48	870	23088 CAKE4	3 150 000	H 3088	GS 88
173	163	M 48	M 48	940	23092 CAKE4	3 450 000	H 3092	GS 92
175	165	M 48	M 48	1 040	23096 CAKE4	3 800 000	H 3096	GS 96

Note ⁽¹⁾ Including oil seal.

To place an order for a complete unit, please specify, "Plummer block bearing box+bearing+adapter".

Remarks 1. The threads for oil replenishing hole plugs are R 1/4 and those for drain plugs are R 3/8.

2. The plummer block bearing boxes listed above are provided with eye bolts.

Note ⁽²⁾ Applicable to the ZF Type with the same number.

SG 5, SG 5-0 Types
Shaft Diameter 50 – 180 mm

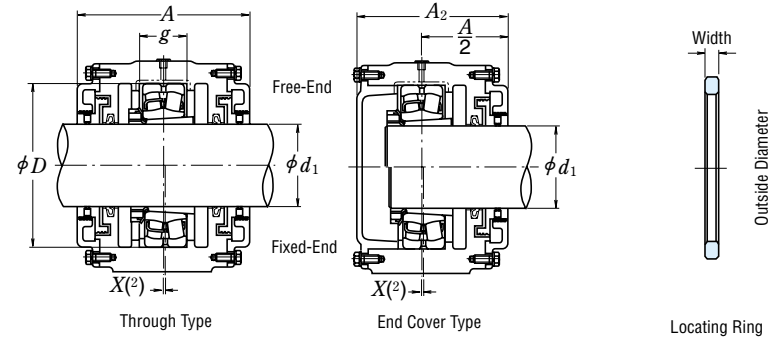
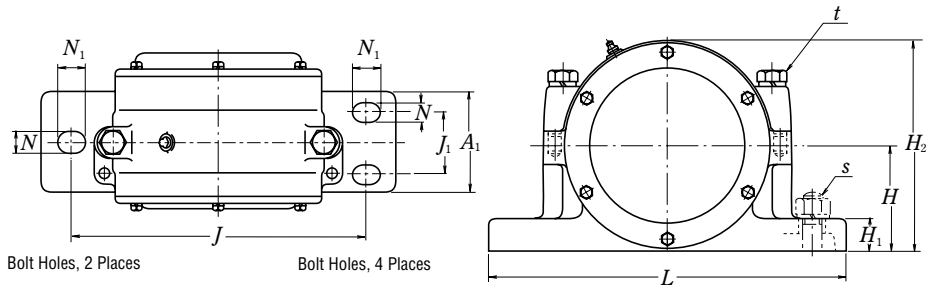

Shaft Diameter (mm) d_1	Plummer Block Bearing Box Numbers ⁽¹⁾		Dimensions (mm)												
	Through Type	End Cover Type	D	H	J	N	N_1	A	L	A_1	H_1	H_2	J_1	A_2	g
			H8	h13											
50	SG 511	SG 511-0	100	70	210	18	23	125	255	70	23	137	—	112.5	29
55	SG 512	SG 512-0	110	80	230	18	23	145	290	80	25	160	—	135	32
60	SG 513	SG 513-0	120	83	230	18	23	130	290	70	25	155	—	115	36
65	SG 515	SG 515-0	130	90	230	18	23	135	290	80	25	168	—	120	36
70	SG 516	SG 516-0	140	95	270	22	27	165	340	120	30	180	70	155	38
75	SG 517	SG 517-0	150	100	280	22	27	170	350	120	30	190	70	160	41
80	SG 518	SG 518-0	160	100	290	22	27	180	360	120	35	200	70	170	45
90	SG 520	SG 520-0	180	125	340	22	27	200	410	130	35	240	70	185	51
100	SG 522	SG 522-0	200	140	380	22	27	210	460	130	40	265	70	190	58
110	SG 524	SG 524-0	215	140	380	22	27	230	460	130	45	275	80	200	63
115	SG 526	SG 526-0	230	150	410	26	32	240	490	160	45	295	80	220	69
125	SG 528	SG 528-0	250	160	435	26	32	245	520	160	50	310	80	220	73
135	SG 530	SG 530-0	270	160	465	26	32	265	550	170	50	330	100	240	78
140	SG 532	SG 532-0	290	170	490	26	32	285	580	170	50	350	100	250	85
150	SG 534	SG 534-0	310	180	550	33	42	300	640	180	55	380	100	265	91
160	SG 536	SG 536-0	320	190	600	33	42	325	690	190	55	400	110	285	91
170	SG 538	SG 538-0	340	200	620	42	52	340	730	200	60	420	120	295	97
180	SG 540	SG 540-0	360	210	635	42	52	350	750	210	60	445	130	310	103

t nominal	s nominal	Mass (kg) approx		Applicable Parts				Oil Seals ⁽³⁾	
		Through Type	End Cover Type	Spherical Roller Bearing Numbers	Basic Dynamic Load Ratings C_r (N)	Adapter Numbers	Locating Ring Nominal (Outside Dia.xWidth)		
M 12	M 16	8.5	7.5	22211 EAKE4	119 000	H 311 X	SR 100x4	1	GS 11
M 16	M 16	15	14	22212 EAKE4	142 000	H 312 X	SR 110x4	1	GS 12
M 16	M 16	9.5	8.5	22213 EAKE4	177 000	H 313 X	SR 120x5	1	GS 13
M 16	M 16	12.5	11	22215 EAKE4	190 000	H 315 X	SR 130x5	1	GS 15
M 20	M 20	18.5	17	22216 EAKE4	212 000	H 316 X	SR 140x5	1	GS 16
M 20	M 20	21	20	22217 EAKE4	250 000	H 317 X	SR 150x5	1	GS 17
M 20	M 20	25	23	22218 EAKE4	289 000	H 318 X	SR 160x5	1	GS 18
M 20	M 20	37	34	22220 EAKE4	365 000	H 320 X	SR 180x5	1	GS 20
M 20	M 20	50	45	22222 EAKE4	485 000	H 322 X	SR 200x5	1	GS 22
M 20	M 20	59	53	22224 EAKE4	550 000	H 3124	SR 215x5	1	GS 24
M 24	M 24	67	62	22226 EAKE4	655 000	H 3126	SR 230x5	1	GS 26
M 24	M 24	73	68	22228 CDKE4	645 000	H 3128	SR 250x5	1	GS 28
M 24	M 24	90	80	22230 CDKE4	765 000	H 3130	SR 270x5	1	GS 30
M 24	M 24	105	92	22232 CDKE4	910 000	H 3132	SR 290x5	1	GS 32
M 30	M 30	130	115	22234 CDKE4	990 000	H 3134	SR 310x5	1	GS 34
M 30	M 30	155	135	22236 CDKE4	1 020 000	H 3136	SR 320x5	1	GS 36
M 36	M 36	175	155	22238 CAKE4	1 140 000	H 3138	SR 340x5	1	GS 38
M 36	M 36	210	180	22240 CAKE4	1 300 000	H 3140	SR 360x5	1	GS 40

Note ⁽¹⁾ Including oil seal.

To place an order for a complete unit, please specify, "Plummer block bearing box+bearing+adapter+locating ring".

- Remarks 1. The threads for grease nipples are R 1/8 for SG518 and under, and R 1/4 for SG520 and over.
2. Bearing boxes larger than SG520 are provided with eye bolts.

Notes ⁽²⁾ The X dimension indicates the offset of the bearing center from the center of plummer block bearing box, and it is 1/2 of the locating ring width.

⁽³⁾ Applicable to the ZF Type with the same number.

STEPPED-SHAFT TYPE PLUMMER BLOCKS

SN 2 C, SN 3 C Types
Shaft Diameter 25 – 55 mm

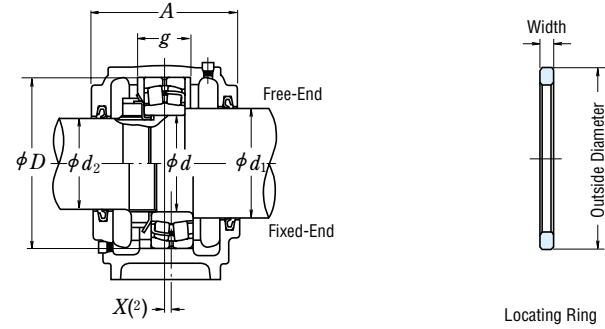
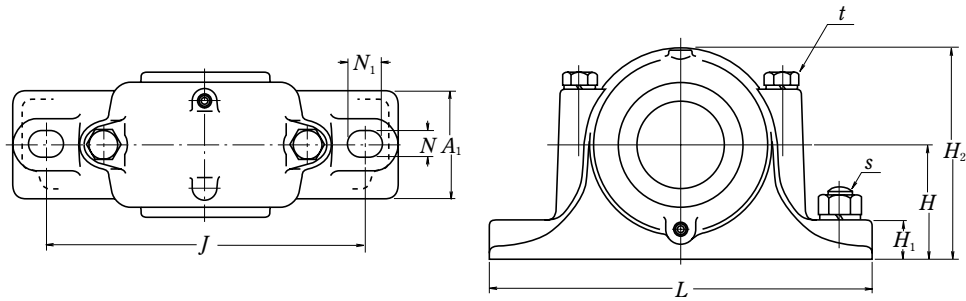

Shaft Diameter (mm) <i>d</i>	Plummer Block Bearing Box Numbers ⁽¹⁾	Dimensions (mm)														
		<i>d</i> ₁	<i>d</i> ₂	<i>D</i> _{H8}	<i>H</i> _{h13}	<i>J</i>	<i>N</i>	<i>N</i> ₁	<i>A</i>	<i>L</i>	<i>A</i> ₁	<i>H</i> ₁	<i>H</i> ₂	<i>g</i> _{H13}	<i>t</i> _{nominal}	<i>s</i> _{nominal}
25	SN 205 C	30	20	52	40	130	15	20	67	165	46	22	75	25	M 8	M 12
	SN 305 C	30	20	62	50	150	15	20	80	185	52	22	90	34	M 8	M 12
30	SN 206 C	35	25	62	50	150	15	20	77	185	52	22	90	30	M 8	M 12
	SN 306 C	35	25	72	50	150	15	20	82	185	52	22	95	37	M 10	M 12
35	SN 207 C	45	30	72	50	150	15	20	82	185	52	22	95	33	M 10	M 12
	SN 307 C	45	30	80	60	170	15	20	90	205	60	25	110	41	M 10	M 12
40	SN 208 C	50	35	80	60	170	15	20	85	205	60	25	110	33	M 10	M 12
	SN 308 C	50	35	90	60	170	15	20	95	205	60	25	115	43	M 10	M 12
45	SN 209 C	55	40	85	60	170	15	20	85	205	60	25	112	31	M 10	M 12
	SN 309 C	55	40	100	70	210	18	23	105	255	70	28	130	46	M 12	M 16
50	SN 210 C	60	45	90	60	170	15	20	90	205	60	25	115	33	M 10	M 12
	SN 310 C	60	45	110	70	210	18	23	115	255	70	30	135	50	M 12	M 16
55	SN 211 C	65	50	100	70	210	18	23	95	255	70	28	130	33	M 12	M 16
	SN 311 C	65	50	120	80	230	18	23	120	275	80	30	150	53	M 12	M 16

Note ⁽¹⁾ Including oil seal.

To place an order for a complete unit, please specify, "Plummer block bearing box+bearing+nut+washer+locating ring".

Remarks The threads for plugs are R 1/8.

Mass (kg) approx	Applicable Parts								Oil Seals ⁽³⁾	
	Self-Aligning Ball Bearing Numbers	B. D. L. R. ⁽⁴⁾ C _r (N)	Spherical Roller Bearing Numbers	B. D. L. R. ⁽⁴⁾ C _r (N)	Nut Numbers	Washer Numbers	Locating Ring Nominal (Outside Dia.×Width)	Qty	Side <i>d</i> ₁	Side <i>d</i> ₂
1.1	1205	12 200	—	—	AN 05	AW 05X	SR 52 × 5	2	GS 7	GS 5
	2205	12 400	22205 CE4	37 500	AN 05	AW 05X	SR 52 × 7	1		
1.6	1305	18 200	21305 CDE4	43 000	AN 05	AW 05X	SR 62 × 8.5	2	GS 7	GS 5
	2305	24 900	—	—	AN 05	AW 05X	SR 62 × 10	1		
1.7	1206	15 800	—	—	AN 06	AW 06X	SR 62 × 7	2	GS 8	GS 6
	2206	15 300	22206 CE4	50 000	AN 06	AW 06X	SR 62 × 10	1		
1.8	1306	21 400	21306 CDE4	55 000	AN 06	AW 06X	SR 72 × 9	2	GS 8	GS 6
	2306	32 000	—	—	AN 06	AW 06X	SR 72 × 10	1		
1.9	1207	15 900	—	—	AN 07	AW 07X	SR 72 × 8	2	GS 10	GS 7
	2207	21 700	22207 CE4	69 000	AN 07	AW 07X	SR 72 × 10	1		
2.6	1307	25 300	21307 CDE4	71 500	AN 07	AW 07X	SR 80 × 10	2	GS 10	GS 7
	2307	40 000	—	—	AN 07	AW 07X	SR 80 × 10	1		
2.6	1208	19 300	—	—	AN 08	AW 08X	SR 80 × 7.5	2	GS 11	GS 8
	2208	22 400	22208 EAE4	90 500	AN 08	AW 08X	SR 80 × 10	1		
2.9	1308	29 800	21308 EAE4	94 500	AN 08	AW 08X	SR 90 × 10	2	GS 11	GS 8
	2308	45 500	22308 EAE4	136 000	AN 08	AW 08X	SR 90 × 10	1		
2.8	1209	22 000	—	—	AN 09	AW 09X	SR 85 × 6	2	GS 12	GS 9
	2209	23 300	22209 EAE4	94 500	AN 09	AW 09X	SR 85 × 8	1		
4.1	1309	38 500	21309 EAE4	119 000	AN 09	AW 09X	SR 100 × 10.5	2	GS 12	GS 9
	2309	55 000	22309 EAE4	166 000	AN 09	AW 09X	SR 100 × 10	1		
3.0	1210	22 800	—	—	AN 10	AW 10X	SR 90 × 6.5	2	GS 13	GS 10
	2210	23 400	22210 EAE4	99 000	AN 10	AW 10X	SR 90 × 10	1		
4.7	1310	43 500	21310 EAE4	142 000	AN 10	AW 10X	SR 110 × 11.5	2	GS 13	GS 10
	2310	65 000	22310 EAE4	197 000	AN 10	AW 10X	SR 110 × 10	1		
4.5	1211	26 900	—	—	AN 11	AW 11X	SR 100 × 6	2	GS 15	GS 11
	2211	26 700	22211 EAE4	119 000	AN 11	AW 11X	SR 100 × 8	1		
5.8	1311	51 500	21311 EAE4	142 000	AN 11	AW 11X	SR 120 × 12	2	GS 15	GS 11
	2311	76 500	22311 EAE4	234 000	AN 11	AW 11X	SR 120 × 10	1		

Notes ⁽²⁾ The *X* dimension indicates the offset of the bearing center from the center of the plummer block bearing box. When one locating ring is used, it is 1/2 of the locating ring width, and when two rings are used, it becomes 0.

⁽³⁾ Applicable to the ZF Type with the same number. ⁽⁴⁾ B. D. L. R. : Basic Dynamic Load Ratings

STEPPED-SHAFT TYPE PLUMMER BLOCKS

SN 2 C, SN 3 C Types
Shaft Diameter 60 – 90 mm

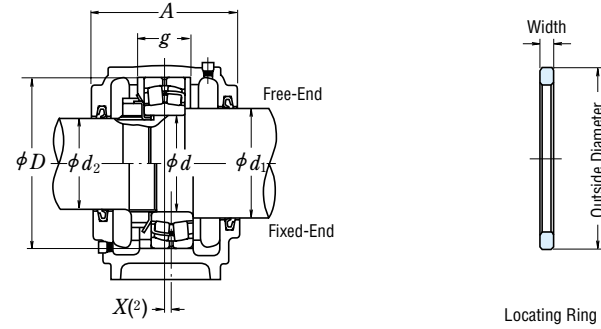
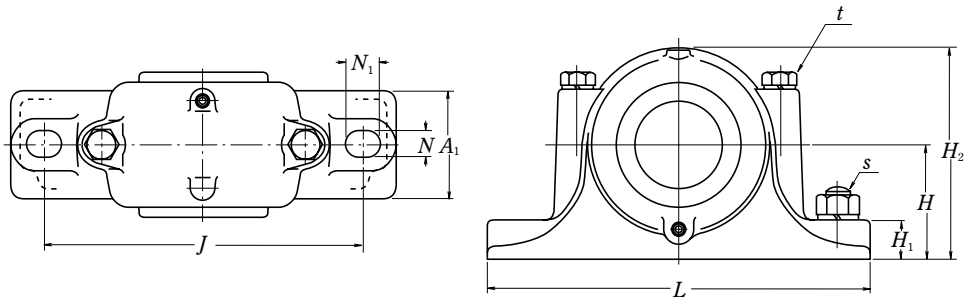

Shaft Diameter (mm) <i>d</i>	Plummer Block Bearing Box Numbers ⁽¹⁾	Dimensions (mm)														
		<i>d</i> ₁	<i>d</i> ₂	<i>D</i> _{H8}	<i>H</i> _{h13}	<i>J</i>	<i>N</i>	<i>N</i> ₁	<i>A</i>	<i>L</i>	<i>A</i> ₁	<i>H</i> ₁	<i>H</i> ₂	<i>g</i> _{H13}	<i>t</i> _{nominal}	<i>s</i> _{nominal}
60	SN 212 C	70	55	110	70	210	18	23	105	255	70	30	135	38	M 12	M 16
	SN 312 C	70	55	130	80	230	18	23	125	280	80	30	155	56	M 12	M 16
65	SN 213 C	75	60	120	80	230	18	23	110	275	80	30	150	43	M 12	M 16
	SN 313 C	75	60	140	95	260	22	27	130	315	90	32	175	58	M 16	M 20
70	SN 214 C	80	65	125	80	230	18	23	115	275	80	30	155	44	M 12	M 16
	SN 314 C	80	65	150	95	260	22	27	130	320	90	32	185	61	M 16	M 20
75	SN 215 C	85	70	130	80	230	18	23	115	280	80	30	155	41	M 12	M 16
	SN 315 C	85	70	160	100	290	22	27	140	345	100	35	195	65	M 16	M 20
80	SN 216 C	90	75	140	95	260	22	27	120	315	90	32	175	43	M 16	M 20
	SN 316 C	90	75	170	112	290	22	27	145	345	100	35	212	68	M 16	M 20
85	SN 217 C	95	80	150	95	260	22	27	125	320	90	32	185	46	M 16	M 20
	SN 317 C	95	80	180	112	320	26	32	155	380	110	40	218	70	M 20	M 24
90	SN 218 C	100	85	160	100	290	22	27	145	345	100	35	195	62.4	M 16	M 20
	SN 318 C	105	85	190	112	320	26	32	160	380	110	40	225	74	M 20	M 24

Note ⁽¹⁾ Including oil seal.

To place an order for a complete unit, please specify, "Plummer block bearing box+bearing+nut+washer+locating ring".

Remarks The threads for plugs are R 1/8 for SN316C, SN218C, and under and R 1/4 for SN317C and over.

Mass (kg) approx	Applicable Parts								Oil Seals ⁽³⁾	
	Self-Aligning Ball Bearing Numbers	B. D. L. R. ⁽⁴⁾ C _r (N)	Spherical Roller Bearing Numbers	B. D. L. R. ⁽⁴⁾ C _r (N)	Nut Numbers	Washer Numbers	Locating Ring Nominal (Outside Dia.×Width)	Qty	Side <i>d</i> ₁	Side <i>d</i> ₂
5.0	1212	30 500	—	—	AN 12	AW 12X	SR 110 × 8	2	GS 16	GS 12
	2212	34 000	22212 EAE4	142 000	AN 12	AW 12X	SR 110 × 10	1		
6.5	1312	57 500	21312 EAE4	190 000	AN 12	AW 12X	SR 130 × 12.5	2	GS 16	GS 12
	2312	88 500	22312 EAE4	271 000	AN 12	AW 12X	SR 130 × 10	1		
5.6	1213	31 000	—	—	AN 13	AW 13X	SR 120 × 10	2	GS 17	GS 13
	2213	43 500	22213 EAE4	177 000	AN 13	AW 13X	SR 120 × 12	1		
8.7	1313	62 500	21313 EAE4	212 000	AN 13	AW 13X	SR 140 × 12.5	2	GS 17	GS 13
	2313	97 000	22313 EAE4	300 000	AN 13	AW 13X	SR 140 × 10	1		
6.2	1214	35 000	—	—	AN 14	AW 14X	SR 125 × 10	2	GS 18	GS 15
	2214	44 000	22214 EAE4	180 000	AN 14	AW 14X	SR 125 × 13	1		
10	1314	65 000	21314 EAE4	250 000	AN 14	AW 14X	SR 150 × 13	2	GS 18	GS 15
	2314	111 000	22314 EAE4	340 000	AN 14	AW 14X	SR 150 × 10	1		
7.0	1215	39 000	—	—	AN 15	AW 15X	SR 130 × 8	2	GS 19	GS 16
	2215	44 500	22215 EAE4	190 000	AN 15	AW 15X	SR 130 × 10	1		
11.3	1315	80 000	21315 EAE4	250 000	AN 15	AW 15X	SR 160 × 14	2	GS 19	GS 16
	2315	125 000	22315 EAE4	390 000	AN 15	AW 15X	SR 160 × 10	1		
9.0	1216	40 000	—	—	AN 16	AW 16X	SR 140 × 8.5	2	GS 20	GS 17
	2216	49 000	22216 EAE4	212 000	AN 16	AW 16X	SR 140 × 10	1		
12.6	1316	89 000	21316 EAE4	284 000	AN 16	AW 16X	SR 170 × 14.5	2	GS 20	GS 17
	2316	130 000	22316 EAE4	435 000	AN 16	AW 16X	SR 170 × 10	1		
10	1217	49 500	—	—	AN 17	AW 17X	SR 150 × 9	2	GS 21	GS 18
	2217	58 500	22217 EAE4	250 000	AN 17	AW 17X	SR 150 × 10	1		
15	1317	98 500	21317 EAE4	289 000	AN 17	AW 17X	SR 180 × 14.5	2	GS 21	GS 18
	2317	142 000	22317 EAE4	480 000	AN 17	AW 17X	SR 180 × 10	1		
13	1218	57 500	—	—	AN 18	AW 18X	SR 160 × 16.2	2	GS 22	GS 19
	2218	70 500	22218 EAE4	289 000	AN 18	AW 18X	SR 160 × 11.2	2		
	—	—	23218 CE4	340 000	AN 18	AW 18X	SR 160 × 10	1		
19	1318	117 000	21318 EAE4	330 000	AN 18	AW 18X	SR 190 × 15.5	2	GS 23	GS 19
	2318	154 000	22318 EAE4	535 000	AN 18	AW 18X	SR 190 × 10	1		

Notes ⁽²⁾ The *X* dimension indicates the offset of the bearing center from the center of the plummer block bearing box. When one locating ring is used, it is 1/2 of the locating ring width, and when two rings are used, it becomes 0.

⁽³⁾ Applicable to the ZF Type with the same number. ⁽⁴⁾ B. D. L. R. : Basic Dynamic Load Ratings

STEPPED-SHAFT TYPE PLUMMER BLOCKS

SN 2 C, SN 3 C Types
Shaft Diameter 95 – 160 mm

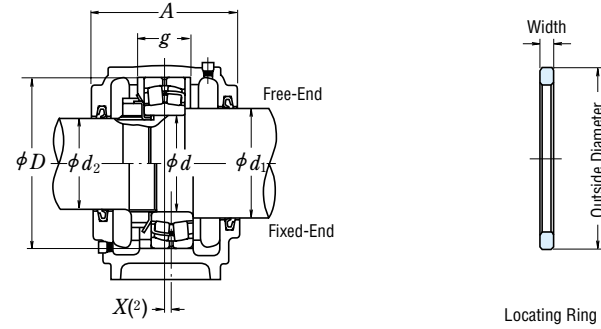
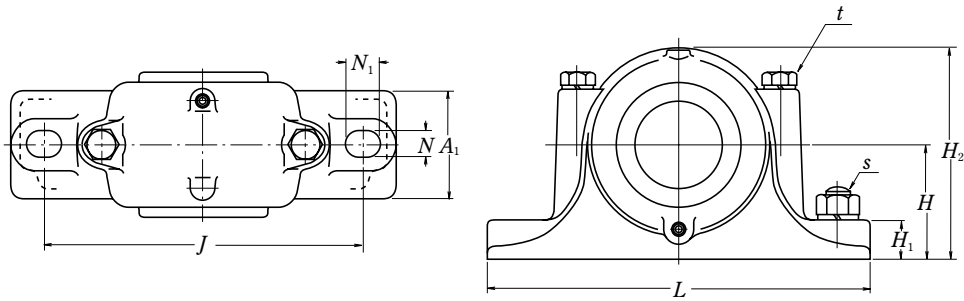

Shaft Diameter (mm) <i>d</i>	Plummer Block Bearing Box Numbers ⁽¹⁾	Dimensions (mm)														
		<i>d</i> ₁	<i>d</i> ₂	<i>D</i> _{H8}	<i>H</i> _{h13}	<i>J</i>	<i>N</i>	<i>N</i> ₁	<i>A</i>	<i>L</i>	<i>A</i> ₁	<i>H</i> ₁	<i>H</i> ₂	<i>g</i> _{H13}	<i>t</i> _{nominal}	<i>s</i> _{nominal}
95	SN 219 C	110	90	170	112	290	22	27	140	345	100	35	210	53	M16	M20
	SN 319 C	110	90	200	125	350	26	32	170	410	120	45	245	77	M20	M24
100	SN 220 C	115	95	180	112	320	26	32	160	380	110	40	218	70.3	M20	M24
	SN 320 C	115	95	215	140	350	26	32	175	410	120	45	270	83	M20	M24
110	SN 222 C	125	105	200	125	350	26	32	175	410	120	45	240	80	M20	M24
	SN 322 C	125	105	240	150	390	28	36	190	450	130	50	300	90	M24	M24
120	SN 224 C	135	115	215	140	350	26	32	185	410	120	45	270	86	M20	M24
	SN 324 C	135	115	260	160	450	33	42	200	530	160	60	320	96	M24	M30
130	SN 226 C	145	125	230	150	380	28	36	190	445	130	50	290	90	M24	M24
	SN 326 C	150	125	280	170	470	33	42	210	550	160	60	340	103	M24	M30
140	SN 228 C	155	135	250	150	420	33	42	205	500	150	50	305	98	M24	M30
	SN 328 C	160	135	300	180	520	35	45	235	610	170	65	365	112	M30	M30
150	SN 230 C	165	145	270	160	450	33	42	220	530	160	60	325	106	M24	M30
	SN 330 C	170	145	320	190	560	35	45	245	650	180	65	385	118	M30	M30
160	SN 232 C	175	150	290	170	470	33	42	235	550	160	60	345	114	M24	M30
	SN 332 C	180	150	340	200	580	42	50	255	680	190	70	405	124	M30	M36

Mass (kg) approx	Applicable Parts								Oil Seals ⁽³⁾		
	Self-Aligning Ball Bearing		Spherical Roller Bearing		Nut	Washer	Locating Ring		Side <i>d</i> ₁	Side <i>d</i> ₂	
	Numbers	B. D. L. R. ⁽⁴⁾ <i>C</i> _r (N)	Numbers	B. D. L. R. ⁽⁴⁾ <i>C</i> _r (N)	Numbers	Numbers	Nominal (Outside Dia.×Width)	Qty			
15	1219	64 000	—	—	AN 19	AW 19X	SR 170 × 10.5	2	GS 24	GS 20	
	2219	84 000	22219 EAE4	330 000	AN 19	AW 19X	SR 170 × 10	1			
	22	1319	129 000	21319 CE4	345 000	AN 19	AW 19X	SR 200 × 16	2	GS 24	GS 20
		2319	161 000	22319 EAE4	590 000	AN 19	AW 19X	SR 200 × 10	1		
18.5	1220	69 500	—	—	AN 20	AW 20X	SR 180 × 18.1	2	GS 26	GS 21	
	2220	94 500	22220 EAE4	365 000	AN 20	AW 20X	SR 180 × 12.1	2			
	—	—	23220 CE4	420 000	AN 20	AW 20X	SR 180 × 10	1			
25	1320	140 000	21320 CE4	395 000	AN 20	AW 20X	SR 215 × 18	2	GS 26	GS 21	
	2320	187 000	22320 EAE4	690 000	AN 20	AW 20X	SR 215 × 10	1			
20	1222	87 000	—	—	AN 22	AW 22X	SR 200 × 21	2	GS 28	GS 23	
	2222	122 000	22222 EAE4	485 000	AN 22	AW 22X	SR 200 × 13.5	2			
	—	—	23222 CE4	515 000	AN 22	AW 22X	SR 200 × 10	1			
32	1322	161 000	21322 CAE4	395 000	AN 22	AW 22X	SR 240 × 20	2	GS 28	GS 23	
	2322	211 000	22322 EAE4	825 000	AN 22	AW 22X	SR 240 × 10	1			
24.5	—	—	22224 EAE4	550 000	AN 24	AW 24	SR 215 × 14	2	GS 30	GS 26	
	—	—	23224 CE4	630 000	AN 24	AW 24	SR 215 × 10	1			
48	—	—	22324 EAE4	955 000	AN 24	AW 24	SR 260 × 10	1	GS 30	GS 26	
	—	—	22226 EAE4	655 000	AN 26	AW 26	SR 230 × 13	2	GS 33	GS 28	
30	—	—	23226 CE4	700 000	AN 26	AW 26	SR 230 × 10	1			
	—	—	22326 CE4	995 000	AN 26	AW 26	SR 280 × 10	1	GS 34	GS 28	
56	—	—	22228 CDE4	645 000	AN 28	AW 28	SR 250 × 15	2	GS 35	GS 30	
	—	—	23228 CE4	835 000	AN 28	AW 28	SR 250 × 10	1			
72	—	—	22328 CE4	1 160 000	AN 28	AW 28	SR 300 × 10	1	GS 36	GS 30	
	—	—	22230 CDE4	765 000	AN 30	AW 30	SR 270 × 16.5	2	GS 37	GS 33	
46	—	—	23230 CE4	975 000	AN 30	AW 30	SR 270 × 10	1			
	—	—	22330 CAE4	1 220 000	AN 30	AW 30	SR 320 × 10	1	GS 38	GS 33	
98	—	—	22232 CDE4	910 000	AN 32	AW 32	SR 290 × 17	2	GS 39	GS 34	
	—	—	23232 CE4	1 100 000	AN 32	AW 32	SR 290 × 10	1			
50	—	—	22332 CAE4	1 360 000	AN 32	AW 32	SR 340 × 10	1	GS 40	GS 34	
	—	—	—	—	—	—	—	—	—	—	

Note ⁽¹⁾ Including oil seal.
To place an order for a complete unit, please specify, "Plummer block bearing+bearing+nut+washer+locating ring".
Remarks 1. The threads for plugs are R 1/8 for SN219C, and R 1/4 for SN319C and SN220C and over.
2. Bearing boxes larger than SN320C and SN224C are provided with eye bolts.

Notes ⁽²⁾ The *X* dimension indicates the offset of the bearing center from the center of the plummer block bearing box. When one locating ring is used, it is 1/2 of the locating ring width, and when two rings are used, it becomes 0.

⁽³⁾ Applicable to the ZF Type with the same number. ⁽⁴⁾ B. D. L. R. : Basic Dynamic Load Ratings

STEPPED-SHAFT TYPE PLUMMER BLOCKS

SD 2 C, SD 3 C Types

Shaft Diameter 170 – 320 mm

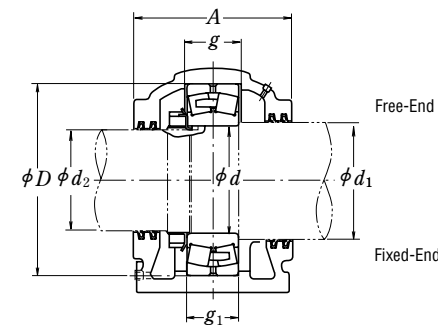
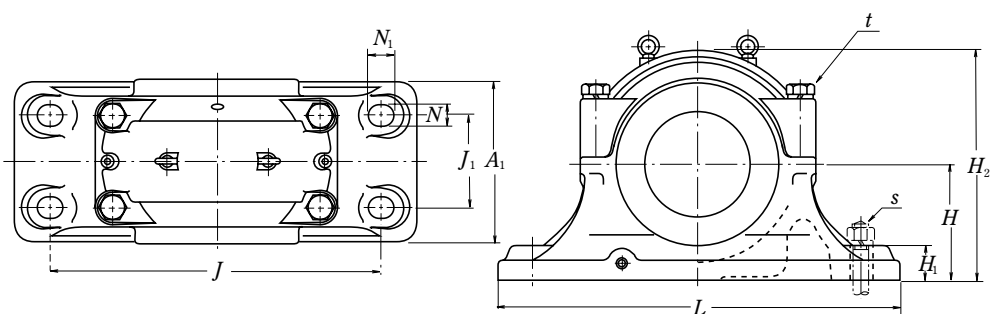

Shaft Diameter (mm) <i>d</i>	Plummer Block Bearing Box Numbers ⁽¹⁾		Dimensions (mm)												
	Free-End	Fixed-End	<i>d</i> ₁	<i>d</i> ₂	<i>D</i> _{H8}	<i>H</i> _{h13}	<i>J</i>	<i>N</i>	<i>N</i> ₁	<i>A</i>	<i>L</i>	<i>A</i> ₁	<i>H</i> ₁	<i>H</i> ₂	<i>J</i> ₁
	170	SD 234 C	SD 234 CG	190	160	310	180	510	36	46	270	620	250	60	360
	SD 334 C	SD 334 CG	190	160	360	210	610	36	46	300	740	290	65	420	170
180	SD 236 C	SD 236 CG	200	170	320	190	540	36	46	280	650	260	60	380	150
	SD 336 C	SD 336 CG	200	170	380	225	640	43	59	320	780	310	70	450	180
190	SD 238 C	SD 238 CG	210	180	340	200	570	36	46	290	700	280	65	400	160
	SD 338 C	SD 338 CG	210	180	400	240	680	43	59	330	820	320	70	475	190
200	SD 240 C	SD 240 CG	220	190	360	210	610	36	46	300	740	290	65	420	170
	SD 340 C	SD 340 CG	220	190	420	250	710	43	59	350	860	340	85	500	200
220	SD 244 C	SD 244 CG	240	210	400	240	680	43	59	330	820	320	70	475	190
	SD 344 C	SD 344 CG	240	210	460	280	770	43	59	360	920	350	85	550	210
240	SD 248 C	SD 248 CG	260	230	440	260	740	43	59	340	880	330	85	515	200
	SD 348 C	SD 348 CG	260	230	500	300	830	50	67	390	990	380	100	590	230
260	SD 252 C	SD 252 CG	280	250	480	280	790	43	59	370	940	360	85	560	210
	SD 352 C	SD 352 CG	280	250	540	325	890	50	67	410	1 060	400	100	640	250
280	SD 256 C	SD 256 CG	300	260	500	300	830	50	67	390	990	380	100	590	230
	SD 356 C	SD 356 CG	300	260	580	355	930	57	77	440	1 110	430	110	690	270
300	SD 260 C	SD 260 CG	320	280	540	325	890	50	67	410	1 060	400	100	640	250
320	SD 264 C	SD 264 CG	340	300	580	355	930	57	77	440	1 110	430	110	690	270

Note ⁽¹⁾ Including oil seal.

To place an order for a complete unit, please specify, "Plummer block bearing box+bearing+nut+washer or stopper".

Remarks 1. The threads for oil replenishing hole plugs are R 1/4 and those for drain plugs are R 3/8.

2. The plummer block bearing boxes listed above are provided with eye bolts.

<i>g</i> _{H13}	<i>g</i> ₁ _{H13}	<i>t</i> _{nominal}	<i>s</i> _{nominal}	Mass (kg) approx	Applicable Parts			Oil Seals ⁽²⁾		
					Spherical Roller Bearing Numbers	Nut Basic Dynamic Load Ratings <i>C</i> _r (N)	Washer or Stopper Numbers	Side <i>d</i> ₁	Side <i>d</i> ₂	
					96	86	M 24	M 30	100	22234 CDE4
130	120	M 30	M 30	160	22334 CAE4	1 580 000	AN 34	AW 34	GS 42	GS 36
96	86	M 24	M 30	110	22236 CDE4	1 020 000	AN 36	AW 36	GS 44	GS 38
136	126	M 30	M 36	195	22336 CAE4	1 740 000	AN 36	AW 36	GS 44	GS 38
102	92	M 30	M 30	130	22238 CAE4	1 140 000	AN 38	AW 38	GS 46	GS 40
142	132	M 30	M 36	210	22338 CAE4	1 890 000	AN 38	AW 38	GS 46	GS 40
108	98	M 30	M 30	155	22240 CAE4	1 300 000	AN 40	AW 40	GS 48	GS 42
148	138	M 36	M 36	240	22340 CAE4	2 000 000	AN 40	AW 40	GS 48	GS 42
118	108	M 30	M 36	205	22244 CAE4	1 570 000	AN 44	AL 44	GS 52	GS 46
155	145	M 36	M 36	315	22344 CAE4	2 350 000	AN 44	AL 44	GS 52	GS 46
130	120	M 36	M 36	240	22248 CAE4	1 870 000	AN 48	AL 44	GS 56	GS 50
165	155	M 36	M 42	405	22348 CAE4	2 600 000	AN 48	AL 44	GS 56	GS 50
140	130	M 36	M 36	315	22252 CAE4	2 180 000	AN 52	AL 52	GS 60	GS 54
175	165	M 36	M 42	480	22352 CAE4	3 100 000	AN 52	AL 52	GS 60	GS 54
140	130	M 36	M 42	390	22256 CAE4	2 280 000	AN 56	AL 52	GS 64	GS 56
185	175	M 42	M 48	610	22356 CAE4	3 500 000	AN 56	AL 52	GS 64	GS 56
150	140	M 36	M 42	465	22260 CAE4	2 610 000	AN 60	AL 60	GS 68	GS 60
160	150	M 42	M 48	595	22264 CAE4	2 990 000	AN 64	AL 64	GS 72	GS 64

Note ⁽²⁾ Applicable to the ZF Type with the same number.