

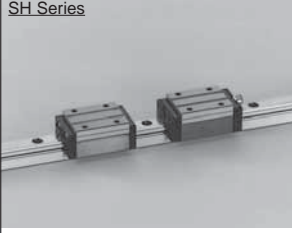

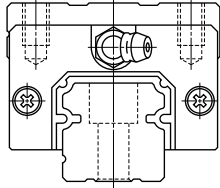

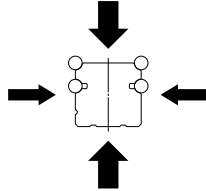

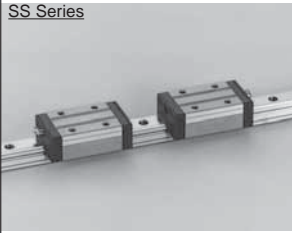

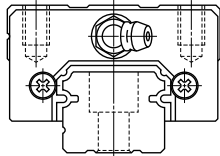
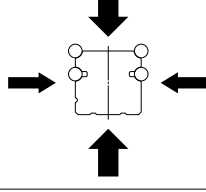
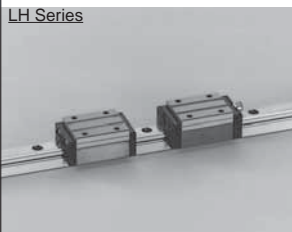
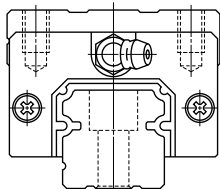
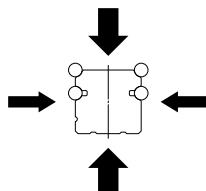
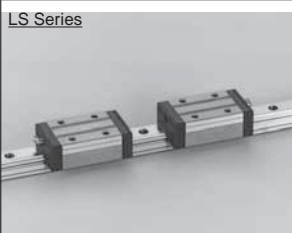
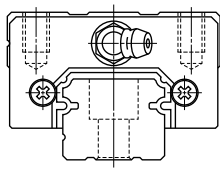
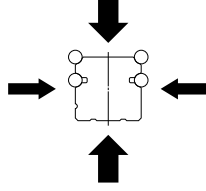
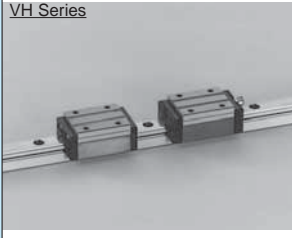
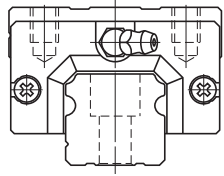
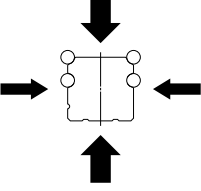

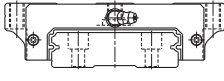
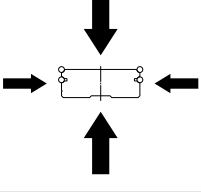

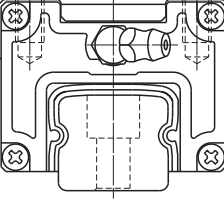
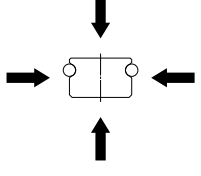

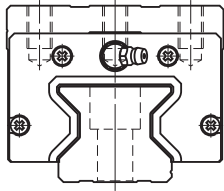
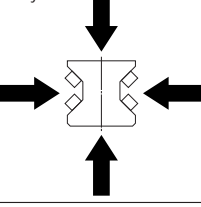
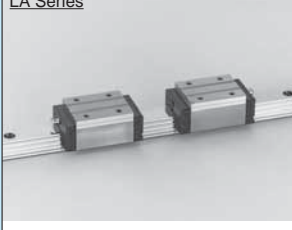
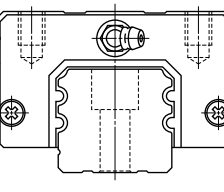
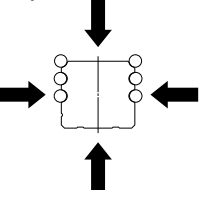







A-2 Types of NSK Linear Rolling Guides

Product	Appearance	Shape	Rolling element	Load capability
NSK Linear Guides	SH Series 		Ball	High vertical load carrying capacity 
	SS Series 		Ball	High vertical load carrying capacity 
	LH Series 		Ball	High vertical load carrying capacity 
	LS Series 		Ball	High vertical load carrying capacity 







Rigidity ; ☆ : Extremely high ◎ : High ◉ : Medium ○ : Low
 Friction characteristic ; ◎ : Low ○ : Normal
 Mounting ; ◎ : Good ○ : Fair



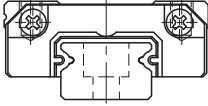
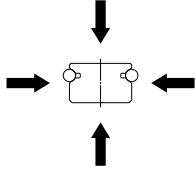

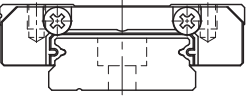
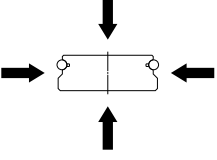
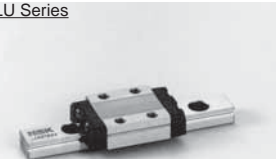
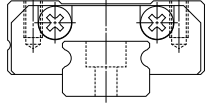
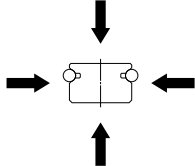
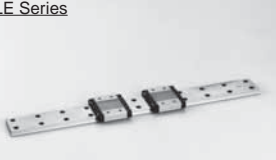

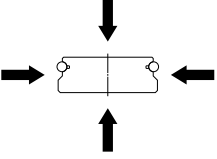
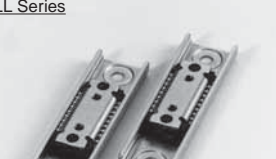

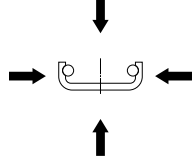





Rigidity	Friction characteristic	Mounting	Major applications	Page
◎	◎	◎	<ul style="list-style-type: none"> Industrial robots Materials handling Semiconductor manufacturing equipment Laser processing machines Electric discharge machines Packaging/packing machines 	A115
◎	◎	◎	<ul style="list-style-type: none"> Industrial robots Materials handling Electric discharge machines Semiconductor manufacturing equipment Packaging/packing machines Pneumatic components 	A139
◎	◎	◎	<ul style="list-style-type: none"> Industrial robots Materials handling Semiconductor manufacturing equipment Woodworking machines Laser processing machines Electric discharge machines Packaging/packing machines 	A161
◎	◎	◎	<ul style="list-style-type: none"> Industrial robots Materials handling Electric discharge machines Woodworking machines Semiconductor manufacturing equipment Packaging/packing machines Pneumatic components 	A185









Product	Appearance	Shape	Rolling element	Load capability
NSK Linear Guides	VH Series 		Ball	High vertical load carrying capacity 
	LW Series 		Ball	High vertical load carrying capacity 
	TS Series 		Ball	Four-directional iso-load carrying capacity 
	RA Series 		Roller	Four-directional iso-load carrying capacity 
	LA Series 		Ball	Four-directional iso-load carrying capacity 

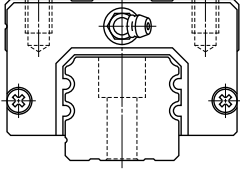
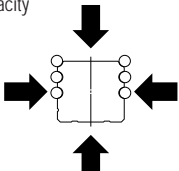

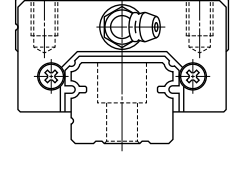
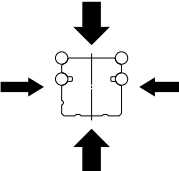

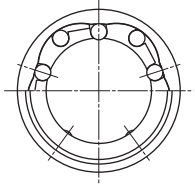
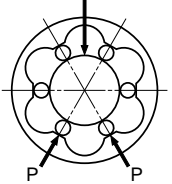

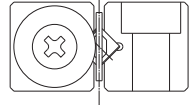
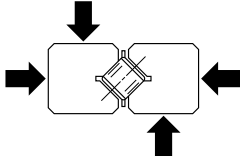

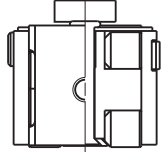
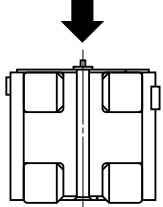
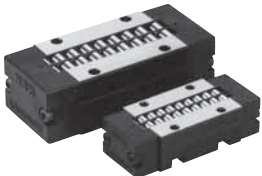
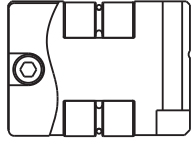
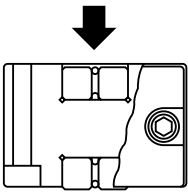









Rigidity	Friction characteristic	Mounting	Major applications	Page
			<ul style="list-style-type: none"> Industrial robots Materials handling Woodworking machines Laser processing machines Electric discharge machines Packaging/packing machines 	A207
			<ul style="list-style-type: none"> Industrial robots Materials handling Electric discharge machines Woodworking machines Semiconductor manufacturing equipment Packaging/packing machines Pneumatic components 	A229
			<ul style="list-style-type: none"> Industrial robots Materials handling Woodworking machines Laser processing machines Electric discharge machines Packaging/packing machines 	A243
			<ul style="list-style-type: none"> Machining centers NC lathes Heavy cutting machine tools Grinders Gear cutting machines Press Electric discharge machines 	A251
			<ul style="list-style-type: none"> Machining centers NC lathes Heavy cutting machine tools Grinders Gear cutting machines Press Electric discharge machines 	A269



Product	Appearance	Shape	Rolling element	Load capability
NSK Linear Guides	<p>PU Series</p> 		Ball	<p>Four-directional iso-load carrying capacity</p> 
	<p>PE Series</p> 		Ball	<p>Four-directional iso-load carrying capacity</p> 
	<p>LU Series</p> 		Ball	<p>Four-directional iso-load carrying capacity</p> 
	<p>LE Series</p> 		Ball	<p>Four-directional iso-load carrying capacity</p> 
	<p>LL Series</p> 		Ball	<p>Four-directional iso-load carrying capacity</p> 

Rigidity	Friction characteristic	Mounting	Major applications	Page
			<ul style="list-style-type: none"> • Semiconductor manufacturing equipment • Liquid crystal display manufacturing equipment • Medical equipment • Optical stage • Microscope XY stage • Small robots • Pneumatic equipment • Computer peripheral equipment 	A289
			<ul style="list-style-type: none"> • Semiconductor manufacturing equipment • Liquid crystal display manufacturing equipment • Medical equipment • Optical stage • Microscope XY stage • Small robots • Pneumatic equipment • Computer peripheral equipment 	A299
			<ul style="list-style-type: none"> • Semiconductor manufacturing equipment • Liquid crystal display manufacturing equipment • Medical equipment • Optical stage • Microscope XY stage • Small robots • Pneumatic equipment • Computer peripheral equipment 	A309
			<ul style="list-style-type: none"> • Semiconductor manufacturing equipment • Liquid crystal display manufacturing equipment • Medical equipment • Optical stage • Microscope XY stage • Small robots • Pneumatic equipment • Computer peripheral equipment 	A321
			<ul style="list-style-type: none"> • Knitting machines • Computer peripheral equipment • Pneumatic equipment • Office equipment 	A335

Product	Appearance	Shape	Rolling element	Load capability
NSK Linear Guides	HA Series 		Ball	Four-directional iso-load carrying capacity 
	HS Series 		Ball	High vertical load carrying capacity 
Linear rolling bushing			Ball	
Crossed roller guide			Roller	
Roller pack			Roller	
Linear roller bearing			Roller	

Rigidity	Friction characteristic	Mounting	Major applications	Page
			<ul style="list-style-type: none"> • Machining centers • Precision lathes • Grinders • Electric discharge machines • Optical stage • Liquid crystal display manufacturing equipment • Die and mold tooling machine • Precision measuring equipment 	A341
			<ul style="list-style-type: none"> • Machining centers • Precision lathes • Grinders • Electric discharge machines • Optical stage • Liquid crystal display manufacturing equipment • Precision measuring equipment 	A355
			<ul style="list-style-type: none"> • Materials handling • Packaging/packing machines • Medical equipment • Pneumatic components • Office equipment • Assembling machines 	A369
			<ul style="list-style-type: none"> • Precision stage • Measuring equipment • Test equipment • Printed circuit board assembly 	A380
			<ul style="list-style-type: none"> • Large machine tools • Conveyor system for heavy objects (guide for heavy load) 	A386
			<ul style="list-style-type: none"> • Large machine tools • Conveyor system for heavy objects (guide for heavy load) 	A393