

## A-3-7 Rust Prevention (Stainless Steel and Surface Treatment)

### (1) Stainless steel

NSK linear guide is available in stainless steel.

○Stainless steel standard series

PU Series PE Series  
LL Series

○Available in stainless steel

SH Series SS Series  
LH Series LS Series  
LU Series LE Series

Select from the above when using in the environments which invite rust.

### (2) Surface Treatment

#### 1) Recommended surface treatment

Among the surface treatments mentioned above, we recommend "low temperature chrome plating" and "fluoride low temperature chrome plating" for rust prevention because of the result of humidity chamber test for antirust characteristics and their cost-effectiveness.

However, never apply any organic solvent for degreasing because it has adverse effect on antirust characteristics.

Refer to next page for the results of humidity chamber test.

Please consult NSK for other surface treatment.

○Low temperature chrome plating (Electrolytic rust prevention black treatment)

- Used to prevent corrosion, light reflection, and for cosmetic purpose.

○Fluoride low temperature chrome plating

- Fluoroplastic coating is provided following the low temperature chrome plating.
- Resistance to corrosion is higher than electrolytic rust prevention film treatment.

#### 2) Rust prevention of fluoride low temperature chrome plating

The use environment of NSK linear guides is expanding from general industrial machines, semiconductor and liquid crystal manufacturing systems to aerospace equipment.

Among all measures to cope with environment, rust prevention is the most challenging. Such environment includes: Moisture for washers and other equipment; Chemicals used in the wet processing of semiconductor and liquid crystal display manufacturing equipment.

NSK developed electrolytic rust prevention black film treatment (black chrome plating) which is added by fluororesin impregnating treatment. (hereinafter referred as "Fluoride low temperature chrome plating") This surface treatment methods has proved its superiority as the rust prevention of linear guides which are used in above equipment.

#### ● What is "Fluoride low temperature chrome plating ?"

This is a type of black chrome plating which forms a black film (1-2 μm) on the metal surface. Fluoroplastic coating is added to the film to increase corrosion resistance.

- Accuracy control is easily manageable due to low temperature treatment and to an absence of hydrogen embrittlement.
- Product accuracy is less affected due to the thin film which has high corrosion resistance.
- This method is superior to other surface treatments in durability on the rolling surface.
- Inexpensive compared with products by other surface treatment and stainless steel products.

Do not use organic solvent because it adversely affects antirust property of the plating.

### ● Humidity cabinet corrosion resistance test

Table 7.1 Results of the humidity cabinet test

Characteristic		Test sample				
		Fluoride low temperature chrome plating (Recommended)	Hard chrome plating (Reference)	Electroless nickel plating (Reference)	Equivalent to SUS440C material	Standard steel
Rusting	Top	(Ground) B	(Ground) B	(Ground) A	(Ground) C	(Ground) D
	Side	(Ground) A	(Ground) A	(Ground) A	(Ground) C	(Ground) E
	Bottom	(Ground) A	(Ground) A	(Ground) A	(Ground) C	(Ground) E
	End	(Machined) A	(Machined) C	(Machined) A	(Machined) C	(Machined) E
	Chamfer/grinding recess	(Drawn) A	(Drawn) D	(Drawn) A	(Drawn) C	(Drawn) E
Rust prevention ability	Test conditions ● Testing cabinet: High temperature, highly moist cabinet (made by DABAI ESPEC) ● Temperature: 70 °C ● Relative humidity: 95% ● Testing time: 96 h Time to "reach to" and "falling from" the temperature/humidity conditions Reaching: 5 h Falling: 2 h					
Film thickness		5 μm	0.5 - 7 μm	10 μm	—	—
		Rusting	A: No rust	B: Not rust, but some discoloration	C: Spotty rust	D: Light rusted E: Completely rusted

● Corrosion resistance test against chemicals

Table 7.2 Result of the corrosion resistance test

Test conditions Rail base material : Equivalent to SUS440C  
Chemical density : 1 mol/l

Fluoride low temperature chrome plating		Hard chrome plating (reference)	None surface treatment
	Immersed in solution for 24 hrs Nitric acid		
	Immersed in solution for 24 hrs Fluoride		
	Immersed in solution for 72 hrs Hydrochloric acid type washing solution HCl : H <sub>2</sub> O <sub>2</sub> : H <sub>2</sub> O = 1 : 1 : 8		
○	Hydrochloric acid (immersed)	○	▲
○	Sulfuric acid (immersed)	○	×
○	Ammonia or sodium hydroxide	○	△

○: Normal △: Partial surface damage ▲: Overall surface damage ×: Corroded

● Surface treatment durability test

● Total evaluation

Life of surface treatment by peeling

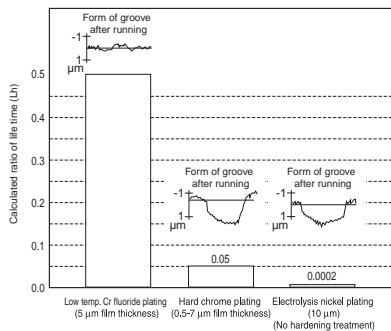

Fig. 7.1 Result of durability test

Table 7.3 Evaluation

	Rust prevention ability	Quality stability	Durability	Cost
Fluoride low temperature chrome plating (recommended)	◎	○	◎	◎
Hard chrome plating (reference)	○	×	△	△
Electroless nickel plating (reference)	◎	△	×	△
Material equivalent to SUS440C	○	◎	◎	△

◎: Excellent ○: Suitable in use  
△: Not very suitable in use ×: Problem in use

A-3-8 Special Environment

(1) Heat-Resistant Specifications

- Standard linear guides use plastic for rolling element recirculation component. The environmental maximum temperature of standard linear guides is 80°C.
- Use linear guide with heat-resistant specifications under temperatures that exceed this limit.

Table 8.1 Comparison of materials: Standard and heat-resistant specifications

Component	Standard specification	Heat-resistant specification
Rail	Special high carbon steel (equivalent to SUS440C/JIS)	Special high carbon steel (equivalent to SUS440C/JIS)
Slide	Special high carbon steel (equivalent to SUS440C/JIS)	Special high carbon steel (equivalent to SUS440C/JIS)
Rolling elements	SUJ2, SUS440C	SUJ2, SUS440C
Retainer	Polyacetals	SUS304
Retaining wire	SUS304	SUS304
End cap	Polyacetals	SUS316L
Return guide	Polyacetals	SUS316L
End seal	Acrylonitril-butadiene rubber, SPC/JIS and stainless steel	Fluoro rubber, SPC/JIS and stainless steel
Bottom seal	Acrylonitril-butadiene rubber, SPC/JIS and stainless steel	Fluoro rubber, SPC/JIS and stainless steel

Heat resistant linear guides

- LH Series
- LW Series
- LE Series
- LS Series
- LU Series

(2) Vacuum and Clean Specifications

- Due to its abundant experience and technology, NSK manufactures linear guides that can be used in a vacuum or in clean environment. Please consult NSK.
- Linear guide specifications vary for environmental conditions. For example, "all stainless steel plus special grease, or solid film lubricant" for vacuum environment.
- NSK has low-dust generating grease "LG2" which is ideal for clean environment. Refer to Page A43 for details.

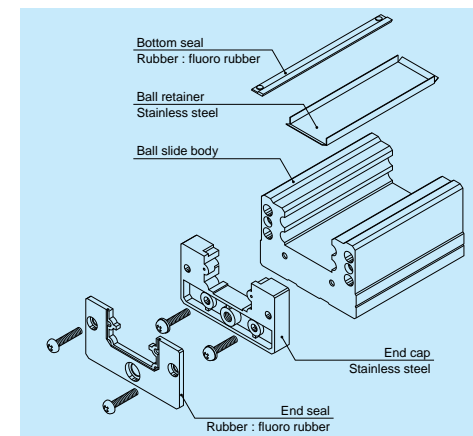
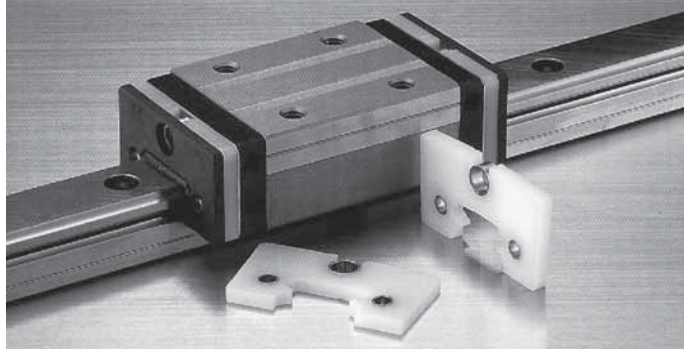

Fig. 8.1

### (3) "NSK Linear Guides for Food Processing Equipment and Medical Devices" for Sanitary Environment

Used with NSK K1 for food processing equipment and medical devices and grease for food processing equipment.



#### What is "NSK K1™" for food processing equipment and medical devices?

With an amazing innovation lubrication unit, the "NSK K1™" for food processing equipment and medical devices utilizing the US Food and Drug Administration (FDA) compliant material, provides reliability when used in food processing equipment and medical devices. The newly developed porous synthetic resin contains abundant lubricant.

With the basic function of highly praised "NSK K1™" lubrication unit for general industry, more sophisticated materials make it applicable in food and medical equipment. It also offers easy installation, mounted inside the standard end seal.

#### 1. Features

◆The highest grade of category H1 grease of USDA standard is used for NSK K1 lubrication unit.

\*category H1: Lubricants permitted for use where there is possibility of incidental food contact

\*USDA: USDA (The United States Department of Agriculture)

<Features of grease for food processing machines>

• This grease is approved by USDA H1. (National Science Foundation [NSF] carries out certification for USDA.)

- Superb water resistance and antirust capability
- Superb wear resistance
- Applicable for a centralized oiling system

◆Appropriate volume of grease

Reduces grease draining and scattering, and maintains a clean environment by supplying appropriate volume of grease.

#### 2. Available models

Table 8.2 shows available models.

Table 8.2

LH Series	LH12, LH15, LH20, LH25, LH30, LH35
LS Series	LS15, LS20, LS25, LS30, LS35
PU Series	PU09, PU12, PU15
PE Series	PE09, PE12, PE15
LU Series	LU09, LU12, LU15
LE Series	LE09, LE12, LE15
LW Series	LW17, LW21, LW27, LW35

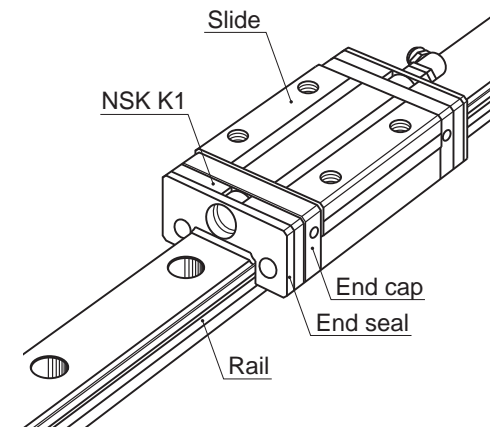

#### Precautions for use

To maintain optimal performance of NSK K1 lubrication unit over a long time, please follow the instructions below:

1. Temperatures range for use: Maximum temperature for use: 50°C  
Momentary maximum temperature in use: 80°C
2. Chemicals that should not come to contact:  
Do not leave NSK K1 lubrication unit in organic solvent, white kerosene such as hexane, thinner which removes oil, and rust prevention oil which contains white kerosene.

Note: Water-type cutting oil, oil-type cutting oil, grease such as mineral-type and ester-type do not damage NSK K1 lubrication unit.

(4) Specifications for Special Environments

Table 8.3 Linear guide specifications

Environment	Condition	NSK linear guide specifications				Technical Explanation Page No.
		Rail, slide	Steel balls/rollers	Ball Recirculation component	Lubrication/surface treatment	
Clean	Atmosphere, normal temperature	Standard material	Standard material	Standard material	LG2 Grease, LGU Grease	D8
					NSK K1 lubrication unit	D10
		Martensitic stainless steel	Martensitic stainless steel	Austenitic stainless steel	LG2 Grease, LGU Grease	D8
					NSK K1 lubrication unit	D10
Atmosphere-Vacuum, normal temperature Atmosphere-Vacuum up to 200°C	Martensitic stainless steel	Martensitic stainless steel	Austenitic stainless steel	Fluoride low temperature chrome plating	D5	
				Fluoride grease		
Vacuum	Atmosphere-Vacuum, normal temperature Atmosphere-Vacuum up to 200°C Atmosphere-Vacuum up to 300°C High vacuum up to 500°C	Martensitic stainless steel	Martensitic stainless steel	Austenitic stainless steel	Fluoride grease	
					Molybdenum disulfide	
					Special silver film	D7
Corrosion resistance	Vapor, steam	Martensitic stainless steel	Martensitic stainless steel	Austenitic stainless steel		
	Acid, alkali	Standard material	Standard material	Standard material	Fluoride low temperature chrome plating	D5
					Fluoride grease	D5
	Acid, alkali, clean Strong acid, strong alkali Organic solvent	Martensitic stainless steel	Martensitic stainless steel	Austenitic stainless steel	Fluoride low temperature chrome plating	D5
					LG2 Grease, LGU Grease	D8
					Fluoride low temperature chrome plating	D5
					Fluoride grease	
	High temperature	Atmosphere up to 150°C	Standard material	Standard material	Austenitic stainless steel	ET150 Grease
Atmosphere Up to 200°C		Martensitic stainless steel	Martensitic stainless steel	Austenitic stainless steel	Fluoride grease	
Atmosphere Up to 200°C, Corrosion resistant					Fluoride grease	
Low temperature	-273 °C -	Martensitic stainless steel	Martensitic stainless steel	Austenitic stainless steel	Solid lubricant	
Radiation resistance	Atmosphere	Standard material	Standard material	Standard material	Radiation resistant grease	
		Martensitic stainless steel	Martensitic stainless steel	Austenitic stainless steel		
Foreign matters	Fine particles, wooden chips	Standard material	Standard material	Standard material	NSK K1 lubrication unit	D10
			Martensitic stainless steel	Austenitic stainless steel		D10
	Water, under water	Martensitic stainless steel	Standard material	Standard material		D10
			Martensitic stainless steel	Austenitic stainless steel		D10

(5) Lubrication and Materials

1. Lubrication

Grease can be used for high rotation and magnetic field. However, grease evaporates or solidifies in special environment such as vacuum, high temperature, and low temperature. Solid lubricant is used when it is difficult to use grease. Functions of solid lubricant differ greatly by condition where it is used. It is important to select the most suitable solid lubrication for the environment.

Fig. 8.2 Lubrication in clean environment

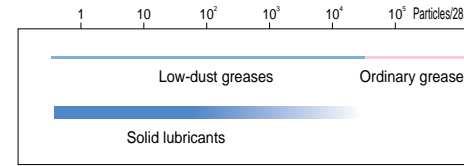

Fig. 8.3 Lubrication in vacuum

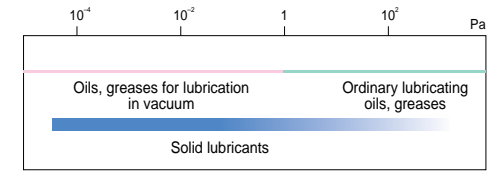

Fig. 8.4 Lubrication in corrosive environment

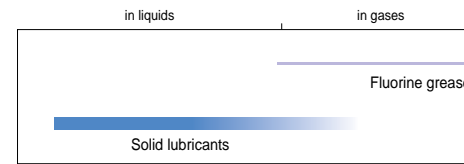

Fig. 8.5 Lubrication in high temperature

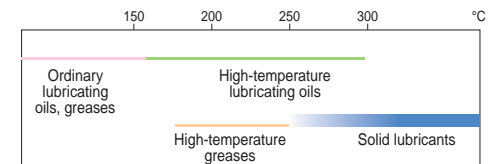

Fig. 8.6 Lubrication in low temperature

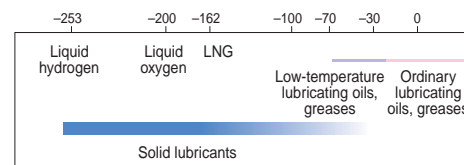

Fig. 8.7 Lubrication in radioactive environment

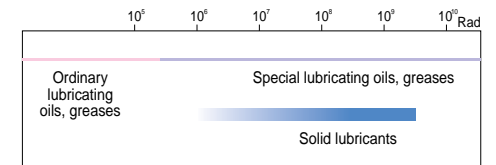
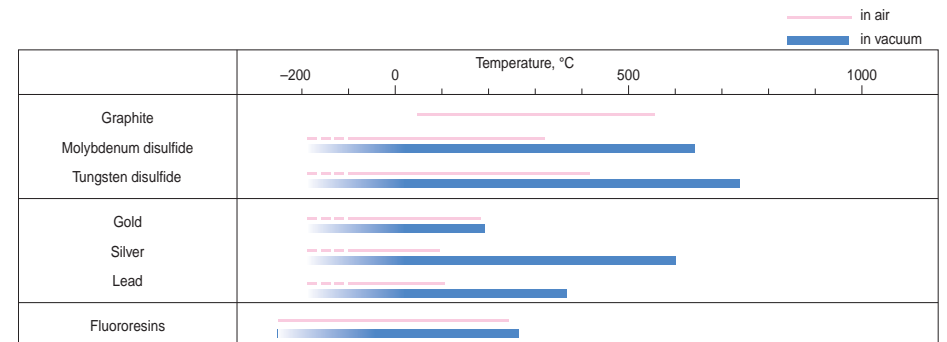

Fig. 8.8 Temperature range for using solid lubricants



## 2. Materials

Steel type metals are used in vacuum, high temperature, and high speed environments as the basic material. We generally use nonmagnetic stainless steel for nonmagnetic materials.

Table 8.4 Characteristics of metal materials

Application	Type of steel	Linear expansivity ×10 <sup>-6</sup> /°C	Young's modulus GPa	Hardness <sup>*)</sup> HB
For clean environment, vacuum environment, corrosion resistance, low temperature, high temperature, radioactive resistance	Martensitic stainless steel SUS440C	10.1	200	580
	Austenitic stainless steel SUS304	16.3	193	150
	Precipitation hardening stainless steel SUS630	10.8	200	277 - 363
Nonmagnetic	Nonmagnetic stainless steel	17.0	195	420

\*) Hardness of steel is usually indicated by Rockwell C Scale. For comparison, these figures are expressed by Brinell number.

## 3. Table to Cope With Special Environments

Series	Model No.	Special environment which linear guide can tolerate					
		Clean	Vacuum	Corrosion	High temp.	Hygienic	High dust proofing
SH	SH15	○		○			
	SH20	○		○			
	SH25	○		○			
	SH30	○		○			
	SH35	○		○			
	SH45	○		○			
	SH55	○		○			
	SS15	○		○			
	SS20	○		○			
	SS25	○		○			
SS	SS30	○		○			
	SS35	○		○			
	LH08	○		○			
LH	LH10	○		○			
	LH12	○		○		○	
	LH15	○	○	○	○	○	○
	LH20	○	○	○	○	○	○
	LH25	○	○	○	○	○	○
	LH30	○	○	○	○	○	○
	LH35	○		○		○	
	LH45	○		○			
	LH55	○		○			
	LH65	○		○			
LS	LS15	○	○	○	○	○	
	LS20	○	○	○	○	○	
	LS25	○	○	○	○	○	
	LS30	○	○	○	○	○	
	LS35	○		○		○	
VH	VH15	○		○	○		○
	VH20	○		○	○		○
	VH25	○		○	○		○
	VH30	○		○	○		○
	VH35	○		○			○
	VH45	○		○			○
	VH55	○		○			○
LW	LW17	○		○		○	
	LW21	○		○		○	
	LW27	○		○		○	
	LW35	○		○		○	
	LW50	○		○			
TS	TS15	○		○			
	TS20	○		○			
	TS25	○		○			
	TS30	○		○			
	TS35	○		○			
RA	RA15	○		○			
	RA20	○		○			

Series	Model No.	Special environment which linear guide can tolerate					
		Clean	Vacuum	Corrosion	High temp.	Hygienic	High dust proofing
RA	RA25	○		○			
	RA30	○		○			
	RA35	○		○			
	RA45	○		○			
	RA55	○		○			
	RA65	○		○			
LA	LA25	○		○			
	LA30	○		○			
	LA35	○		○			
	LA45	○		○			
	LA55	○		○			
	LA65	○		○			
PU	PU05	○		○			
	PU07	○		○			
	PU09	○		○		○	
	PU12	○		○		○	
	PU15	○		○		○	
PE	PE05	○		○			
	PE07	○		○			
	PE09	○		○		○	
LU	PE12	○		○		○	
	PE15	○		○		○	
	LU05	○		○			
	LU07	○		○			
	LU09_L	○	○	○	○	○	○
	LU09_R	○	○	○	○	○	○
	LU12_L	○	○	○	○	○	○
	LU12_R	○	○	○	○	○	○
	LU15	○	○	○	○	○	○
	LE05	○		○			
LE	LE07	○	○	○	○		
	LE09_L	○	○	○	○	○	
	LE09_R	○	○	○	○	○	
	LE12_L	○	○	○	○	○	
	LE12_R	○	○	○	○	○	
	LE15_L	○	○	○	○	○	
HA	LE15AR	○	○	○	○	○	
	HA25	○		○			
	HA30	○		○			
	HA35	○		○			
	HA45	○		○			
HS	HA55	○		○			
	HS15	○		○			
	HS20	○		○			
	HS25	○		○			
	HS30	○		○			
HS35	○		○				

## 4. Precautions for Handling

Please observe the following precautions to maintain high functions of linear guide.

- Products are washed to remove oil, and wrapped in a way to protect them from moisture. Use the product as soon as possible after opening the package.
- After opening, store the products in a clean, air-tight container such as desiccator with desiccating agent (e.g. silica gel). Do not apply rust preventive oil or paper or product that vaporizes rust preventive agent.
- Wear plastic gloves and handle product in clean place.

Note: Please refer to the catalog "CAT. No. E1258 SPACEA" for details of special environmental use.