

A-I Selection Guide to NSK Linear Guides

A-I-1 Structure of NSK Linear Guides

By avoiding structural complexity, and by reducing the number of components, we not only enhanced the precision of linear guides, but also are able to keep costs low. We have added NSK's patented unique structural feature to the original invention (Fig. I-1-1). This contributes to higher precision and lower prices.

NSK linear guide consists of a rail and a ball slide (Fig. I-1.2). The balls roll on the grooves on the rail and the ball slide, and scooped up by the end caps attached to both ends of the ball slide. Then, the balls go through the opening made in the ball slide, and circulate back to the other end.

A-I-2 Characteristics of NSK Linear Guides

The use of a unique offset gothic arch groove (Fig. I-1•3) allows the NSK linear guides to satisfy groove designs required for specific purposes.

The precise measurement of the ball groove leads to stable production of highly accurate linear guides and interchangeable linear guides.

(Fig. I-1•4).

Such technologies ensure the feature of NSK linear guides outlined below.

(1) Abundant in type for any purpose

* Various series are available, and their ball slide models and size categories are standardized to satisfy any requirement. Our technology, polished by abundant experience in the use of special materials and surface treatments, meets the customer's most demanding expectations.

(2) High precision and quality

* High precision and quality come from our superb production and measuring technologies, strengthened by extensive experience in antifriction rotary bearings and ball screw production. Our quality assurance extends to the smallest components.

(3) High reliability and durability

* Logical simplicity in shape, along with stable processing, maintains high precision and reliability.

* Super-clean materials, our advanced heat treatment and processing technologies increase product durability.

(4) Component compatibility shortens delivery time

* Interchangeable parts: The adoption of the gothic-arch groove which makes measuring easy, and a new reliable quality control method has made random-matching of the rails and the ball slides possible. The parts are stocked as standard products, thereby reducing delivery time.

(5) Patented static load carrying capacity (shock-resistance)

* When a super-high load (impact) is applied, our gothic-arch groove spreads the load to surfaces which usually do not come into contact. This increases shock resistance (Fig. I-1•5).

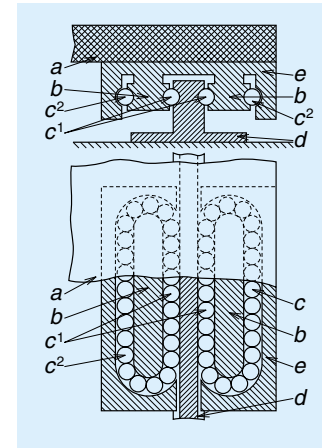

Fig. I-1-1 • French Patent in 1932.
• Inventor : Gretsch (German)

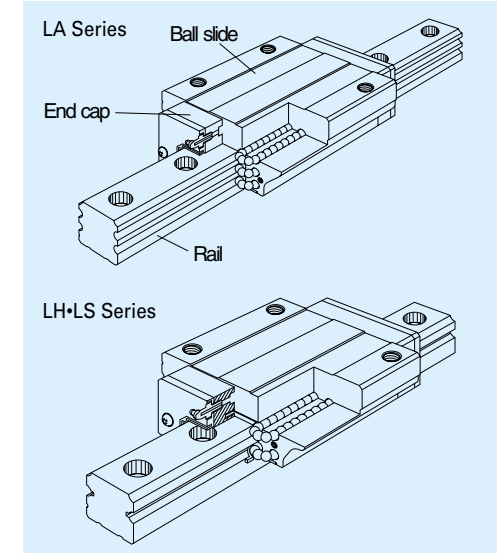

Fig. I-1-2 Structure of NSK linear guides

NSK added its patented technology to the invention in Fig. I-1-1, and improved the linear guide structure and realized low cost design.

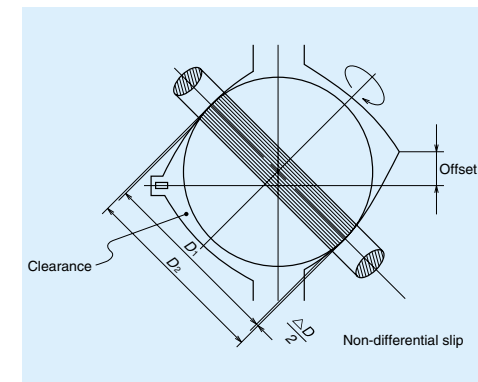

Fig. I-1-3 Offset gothic-arch groove

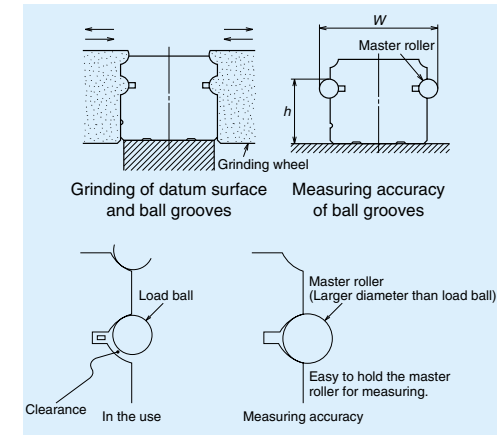

Fig. I-1-4 Processing and measuring grooves

Measuring grooves is easy, and you can obtain highly accurate results for all types of NSK series. This is why you can purchase rail and ball slide separately (interchangeability).

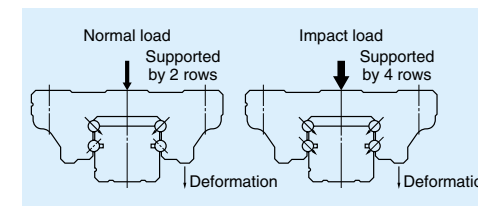

Fig. I-1-5 Shock-resistance

A-I-2.1 Types and Characteristics of NSK Linear Guides

We have abundant types of linear guide for any purpose to accommodate the most special needs of the users.

(1) Types of series and classification by feature

- There are two types of NSK linear guide:
 1. Rigidity and load carrying capacity against the vertical direction are greater than the rigidity and load carrying capacity against the load from the lateral direction (high vertical load carrying capacity type);
 2. Load is equally distributed to four directions (four-directional iso-load carrying capacity type)
- There are three types of NSK linear guide by the length of the ball slide
 1. Standard length ball slide with high-load carrying capacity;

2. Long ball slide with super-high load carrying capacity;
 3. Short ball slide for mid-level load carrying capacity.
- Four-row ball grooves linear guide has two types:
 1. Self-aligning capability- which absorbs certain amount of installation error;
 2. High moment carrying type with great moment rigidity.
 - Two-row ball grooves linear guide has mid-level moment rigidity.
 - Interchangeable parts: Thanks to the ease of measuring gothic-arch groove, we can precisely manufacture rails and ball slides, and thus, you can purchase the rails and the ball slides individually and assemble them randomly.
 - Stainless steel is also available as standard material for some series.

Table I-2.1 Classification of NSK linear guides

Category	Series	Ball slide model	Shape/installation method	Load direction/capacity	Ball groove structure
High vertical load carrying capacity type	Self-aligning type	AL AN BN BL			
		EL GL			
		FL HL			
		EM GM			

Characteristics	Applications	Page
<ul style="list-style-type: none"> ● High load capacity type. ● The contact angle between the ball and ball raceway is set at 50 degrees. The load carrying capacity against the vertical directions, which is prevalent in most operations, increases by this design. ● The DF contact structure greatly absorbs the error in the perpendicular direction to rail at the time of installation. ● Balls make contacts at two points thanks to the offset Gothic-arch groove. This keeps friction to a minimum. ● Structural resistance against shock load. ● Gothic-arch groove renders measuring of ball grooves accurate and easy. ● Standardized interchangeable assemblies allows separate purchase of rails and ball slides. ● Stainless steel type is also available for small sizes (- #30). <p><u>Characteristics of SH series</u></p> <ul style="list-style-type: none"> ● Lower noise and gentler tone. ● Smoother motion. ● Low dust generation. 	<ul style="list-style-type: none"> • Cartesian type robots • Robots that remove plastic molds from injection machine • Material handling • Food processing machines • Packaging/packing machines • Printing machines • Woodworking machines • Paper machines • Measuring equipment • Inspecting equipment • Semiconductor manufacturing equipment • Liquid crystal display manufacturing equipment • Medical equipment • Electric discharge machines • Laser cutting machines • Press • Tool grinders • Flat surface grinders • NC lathes • Machining centers • ATC 	A42 A111

Category	Series	Ball slide model	Shape/installation method	Load direction/capacity	Ball groove structure	
High vertical load carrying capacity type	Self-aligning type	LS SS	AL CL			
			EL JL			
			FL KL			
			EM JM			
			AN BN AL BL			
Four-directional iso-load carrying type	Super-rigid type	LA	EL GL			
			FL HL			
			AN BN AL BL			

Characteristics	Applications	Page
<ul style="list-style-type: none"> ● Compact, low in height ● The contact angle between the ball and the raceway is set at 50 degrees. The load carrying capacity against vertical directions, which is prevalent in most operations, increases by this design. ● The DF contact structure greatly absorbs the error in the perpendicular direction of rail at time of installation. ● Thanks to the offset gothic arch groove, balls make contacts at two points. This keeps friction small. ● Great resistance against shock load. ● Gothic arch groove renders measuring groove accurate and easy. ● Standardized interchangeability allows separate purchase of rails and ball slide. ● Some are standardized stainless steel type. ● Low-noise type <p><u>SS series</u></p> <ul style="list-style-type: none"> ● Lower noise and gentler tone. ● Smoother motion. ● Low dust generation. 	<ul style="list-style-type: none"> • Cartesian type robots • Robots that remove plastic molds from injection machine • Material handling • Food processing machines • Packaging/packing machines • Printing machines • Woodworking machines • Paper machines • Measuring equipment • Inspection equipment • Semiconductor manufacturing equipment • Liquid crystal display manufacturing equipment • Medical equipment • Electric discharge machines • Laser cutting machines • Press 	A42 A119
<ul style="list-style-type: none"> ● The contact angle between the ball and the raceway is set at 45 degrees. This makes load carrying capacity and rigidity equal in vertical and lateral directions. ● Six-row ball grooves support load from vertical and lateral directions, enhancing rigidity and increasing load carrying capacity. ● Appropriate friction ● Best for machine tools. 	<ul style="list-style-type: none"> • Machining centers • NC lathes • Heavy cutting machine tools • Gear cutters • Electric discharge machines • Press • Grinders 	A56

Category	Series	Ball slide model	Shape/installation method	Load direction/capacity	Ball groove structure
Four-directional iso-load carrying type	High rigidity type	AN BN AL BL			 At time of light preload At time of high preload
		LY	EL GL		
		FL HL			
High vertical load carrying capacity type	High moment capacity type	LW	EL		
Miniature	High moment capacity type	LE	AL TL BL UL CL SL AR TR		
Miniature		LU	AL TL BL UL AR TR		
Lightweight miniature		LL	PL		

Characteristics	Applications	Page
<ul style="list-style-type: none"> ● The contact angle between the ball and the raceway is set at 45 degrees. Therefore, load carrying capacity and rigidity are equal in vertical and lateral directions. ● Balls contact at four points during high preload. The four-row ball groove supports the load from vertical and lateral directions. This makes the linear guide highly rigid. ● Rigidity against moment load is great due to the DB contact (at time of light preload) or the four-point contact (at time of high preload) ● Sliding resistance slightly increases, absorbing vibration to the rail longitudinal direction due to the four-point contact at time of high preload. ● Ideal for heavy cutting machine tools. ● Strong against shock load 	<ul style="list-style-type: none"> • Machining centers • NC lathes • Heavy cutting machine tools • Gear cutters 	A66
<ul style="list-style-type: none"> ● The contact angle between the ball and the raceway is set at 50 degrees. The load carrying capacity against vertical directions, which is prevalent in most operations, increases with this design ● The rail is wide. This contributes to a high rolling moment carrying capacity and to great moment rigidity when only single linear guide is in use ● Balls contact at two points in the offset gothic arch groove, keeping friction small. ● High resistance against shock load ● Standardized interchangeable assemblies allows separate purchase of rails and ball slides. 	<ul style="list-style-type: none"> • Semiconductor manufacturing equipment • Liquid crystal display manufacturing equipment • Conveyor systems • Inspection equipment • Punch press 	A76
<ul style="list-style-type: none"> ● Extremely thin, and wide in shape. This is ideal in use of only single linear guide. ● Available in standardized stainless steel ● Standardized series with ball retainer. ● Standardized interchangeability allows separate purchase of rails and ball slide. 	<ul style="list-style-type: none"> • Semiconductor manufacturing equipment • Liquid crystal display manufacturing equipment • Medical equipment • Optical stage 	A82
<ul style="list-style-type: none"> ● Super-small size ● Stainless steel is standard as the material. ● Series with a ball retainer is standardized. ● Interchangeability is standardized, allowing separate purchase of rails and ball slide. 	<ul style="list-style-type: none"> • Microscope XY stage • Conveying optical fiber • Small robots • Computer peripheral equipment • Pneumatic equipment 	A92
<ul style="list-style-type: none"> ● Light-weight and compact ● Stainless steel as standard material is available. 	<ul style="list-style-type: none"> • Knitting machines • Hard disk carriage damper 	A100

A-I-2.2 Models in Each Series and Ball Slide Shape

• "Model" refers to a combination of the linear guide series and its size number with the shape code and height code of the ball slide. Ball slide codes for shape and height are sometimes omitted.

Example of a model:

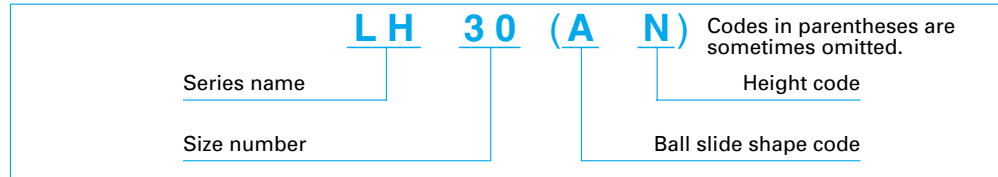

Note: Height code R of LE and LU series refers to low type with ball retainer.

• The combination of ball slide shape and height are shown in table I-2-2

Table I-2-2 Ball slide shape and height codes

Series	Height	Ball slide length	Square type		Flanged type		
			Mounting tap	Mounting tap	Mounting bolt hole	Dual use for tap and bolt holes	
LH SH	High	Standard	AN				
		Long	BN				
	Low	Standard	AL	EL	FL	EM	
		Long	BL	GL	HL	GM	
LS SS	Low	Standard	AL	EL	FL	EM	
		Short	CL	JL	KL	JM	
LA	High	Standard	AN				
		Long	BN				
	Low	Standard	AL	EL	FL		
		Long	BL	GL	HL		
LY	High	Standard	AN				
		Long	BN				
	Low	Standard	AL	EL	FL		
		Long	BL	GL	HL		
LW	Low	Standard		EL			
LE	Low	Standard	AL, TL, AR, TR				
		Long	BL, UL				
		Short	CL, SL				
LU	Low	Standard	AL, TL, AR, TR				
		Long	BL, UL				
LL	Low	Standard	PL				

A-I-3 Procedures for Selecting Linear Guide

A-I-3.1 Flow Chart for Selection

The flow chart below shows general steps for selection.

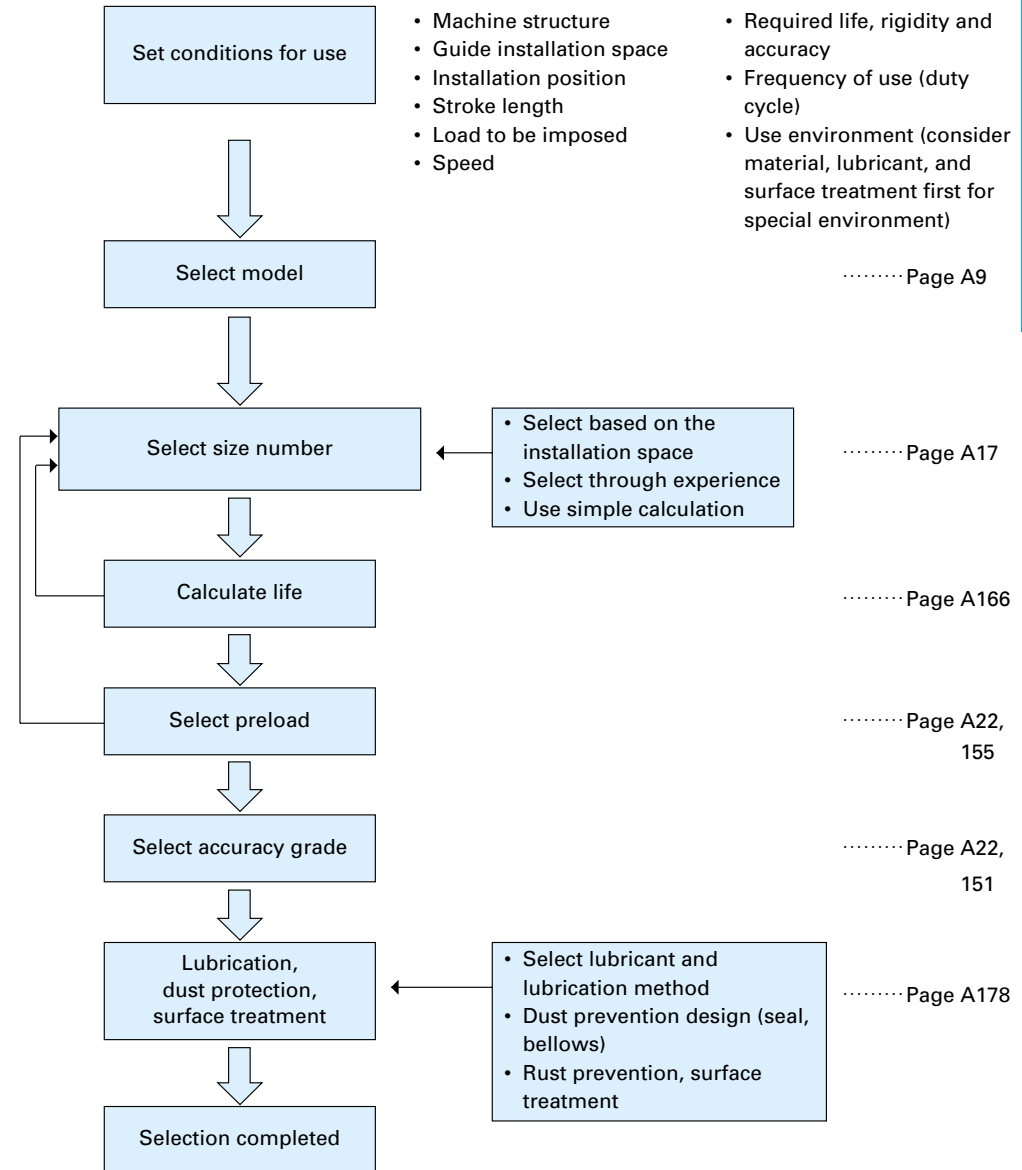

A-I-3.2 Selection of Linear Guide Size (Model number)

To select a linear guide of satisfactory durability; it is a standard practice to calculate its expected life. Prior to calculating the linear guide's life expectancy, select an appropriate size of the linear guide. Below is an easy selection method. After selecting the size by this method, check the life by using the "A-II-3.2: Calculation of Life Expectancy."

(1) Select the size based on the space to be used.

Select a linear guide which matches the space in which it is used. Select directly from the "A-I-5: Model Number and Dimension Table."

(2) Select the size based on the ball screw size.

Always select a linear guide which matches the size of the screw shaft diameter, or the size closest to it, e.g., when the ball screw shaft diameter is 32, select linear guide type LH30, or LH35.

(3) Select the size based on the estimated load on one ball slider.

Most linear guides are table-shaped and have two rails and four ball slides for an axis. Assuming the linear guide is this type, calculate a rough load per ball slide using the formula below:

$$P = \sum \frac{F}{4} + \sum \frac{K_p \cdot F}{2} \quad \dots \dots (3.1)$$

- P** : Load per ball slide
- K_p** : Load position coefficient
- F** : Load

Load position coefficient K_p should be found for each load by the proportion of the distance between ball slide span and load point, and the distance between rail span and load point.

(A) When load is vertical

(Fig. I-3-1)

$$K_p = \left| \frac{X_0}{L_b} \right| + \left| \frac{Y_0}{L_r} \right|$$

(B) When the load is in the axial direction

(Fig. I-3-2)

$$K_p = \left| \frac{Z_1}{L_b} \right| + \left| \frac{Y_1}{L_b} \right|$$

(C) When the load is lateral to the rail

(Fig. I-3-3)

$$K_p = \left| \frac{X_0}{L_b} \right| + \left| \frac{Z_0}{L_r} \right|$$

The load position is normally the coordinate position. Disregard + or - symbols, and use absolute values.

Upon obtaining the load value P per ball slide by using the above position coefficient K_p in (3.1), select the matching size (model number) from Fig. I-3-4. Because the above calculation formula is a simple one, the load obtained by the above formula may be larger than the actual case if the value of K_p is over 1, or in the case three patterns (A), (B), and (C) are combined. In such case, the size to be selected (model number) should be larger; however, the life will be longer.

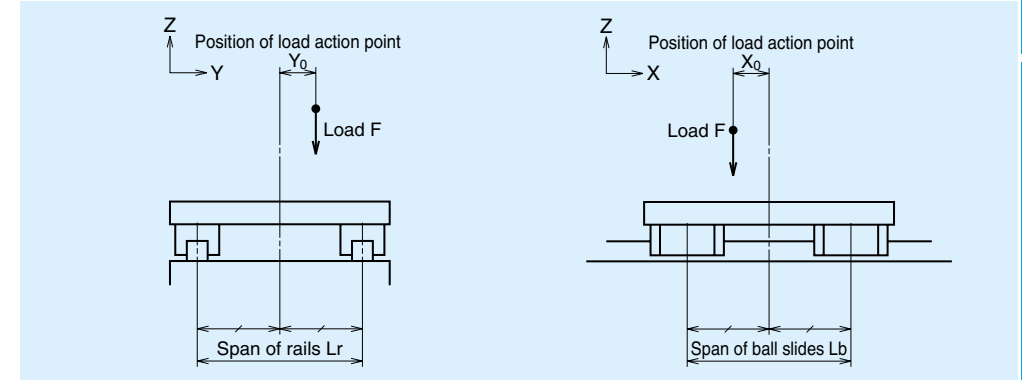

Fig. I-3-1 Load from vertical direction

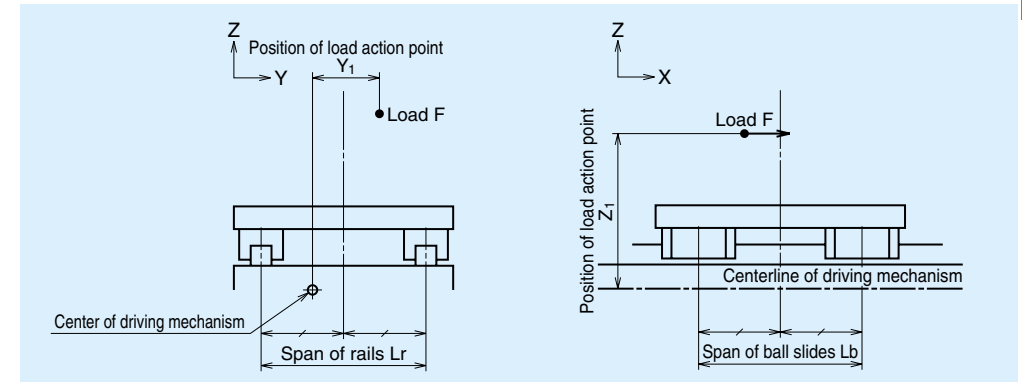

Fig. I-3-2 Load to the axis direction

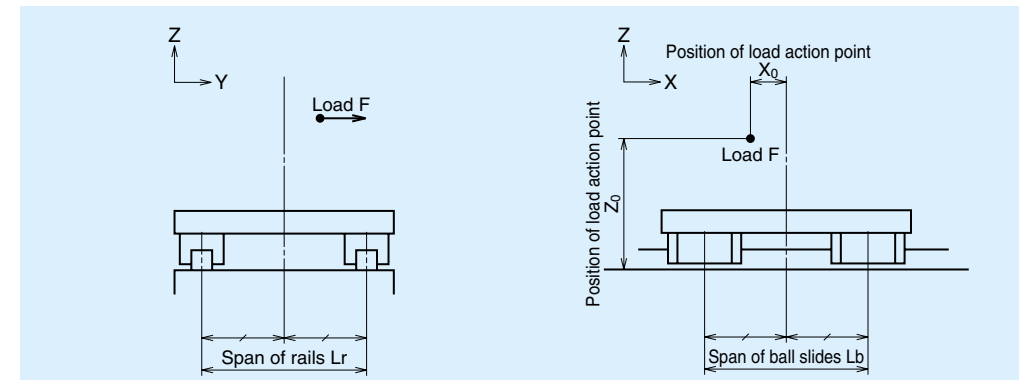

Fig. I-3-3 Load from lateral direction

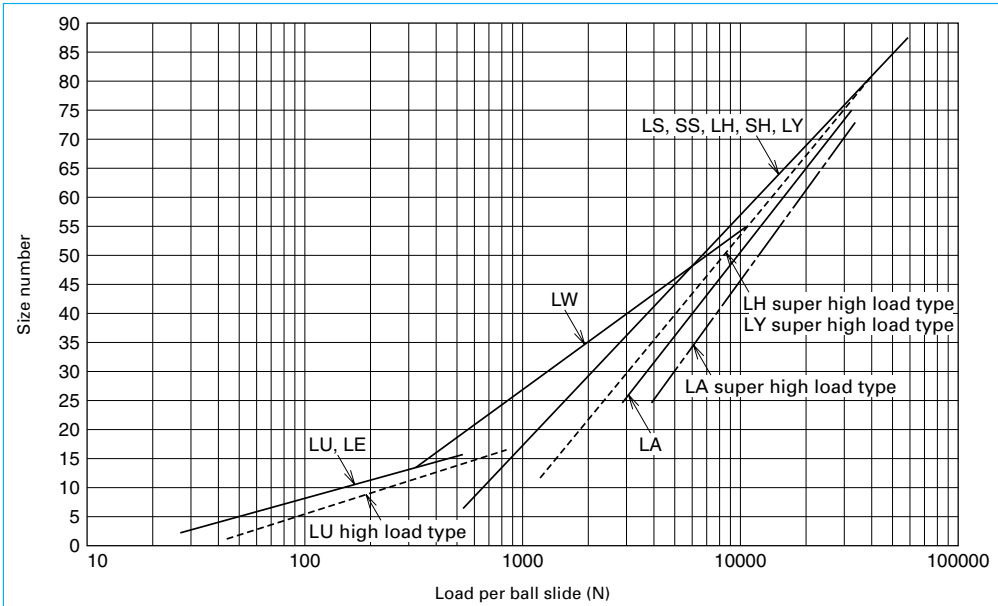

Fig. I-3-4 Selection based on the load

(4) Selection based on the moment load per ball slide

- In cases shown in Fig. I-3-5 to •6, •7, it is necessary to consider the moment load applied to the ball slide.
- Moment directions that have to be taken into account are only those shown by the arrow in the Figures.
- When the load is applied from more than one

direction, select the value of the direction which applies the largest moment load.

- Select the size (model number) based on the moment load per ball slide referring to either Fig. I-3-8 or Fig. I-3-9.
- Consult NSK when: moment load and vertical load are applied at the same time; or moment load and horizontal load are applied at the same time.

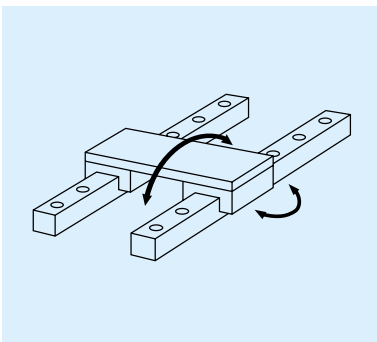

Fig. I-3-5 Pitching and yawing direction

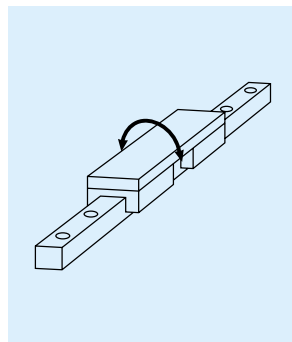

Fig. I-3-6 Rolling direction

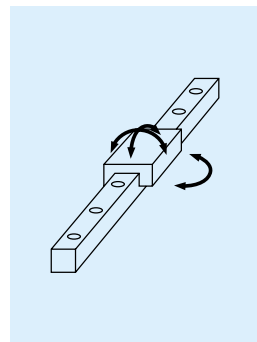

Fig. I-3-7 Pitching, rolling and yawing directions

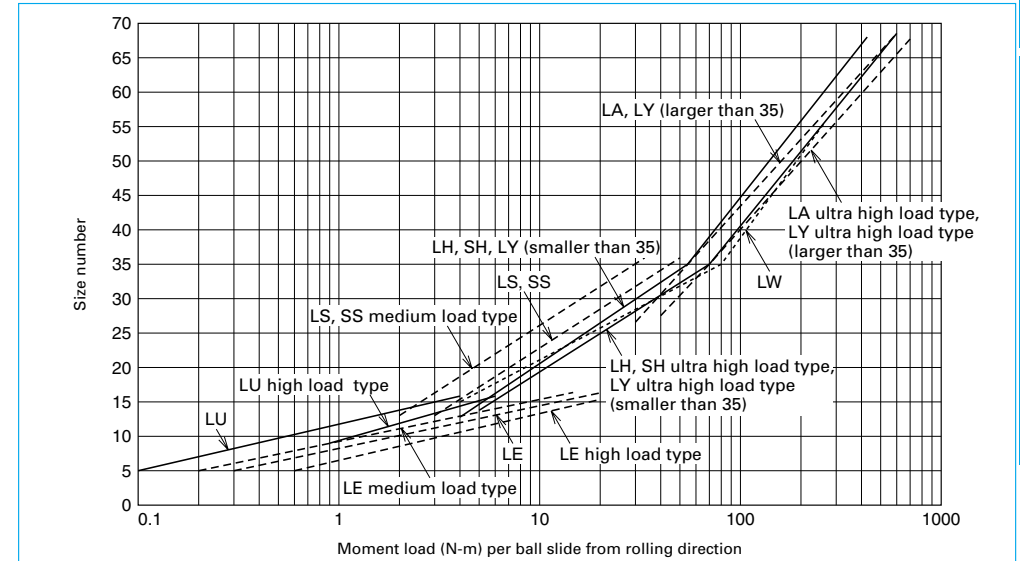

Fig. I-3-8 Selection based on the moment load, rolling direction

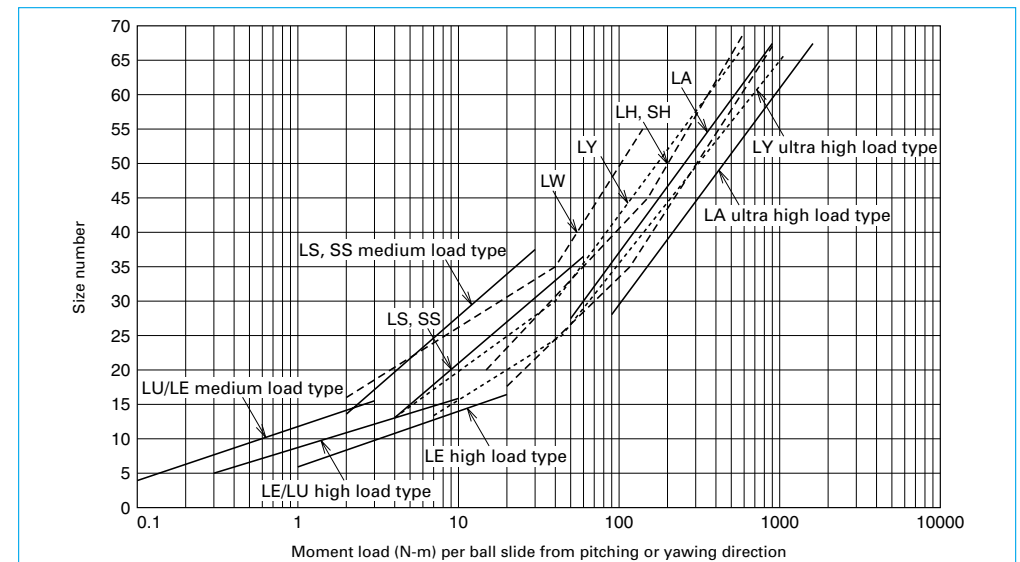

Fig. I-3-9 Selection based on the moment load, pitching or yawing direction

- Loads applied to the types recommended in Fig. I-3-4, I-3-8, and I-3-9 are equivalent to 8% of the basic dynamic load rating of the linear guide. This contributes to select a size number with a longer life.

A-I-3.3 Example of Linear Guide Selection (Model number)

The selection below used "A-I-3.2 (3) Selection based on load per ball slide."

In this example, let us select a linear guide for a single axis table as illustrated below.

Use LH-AN type in LH Series which is selected based on "A-I-2.1 Types and Characteristics of NSK Linear Guides."

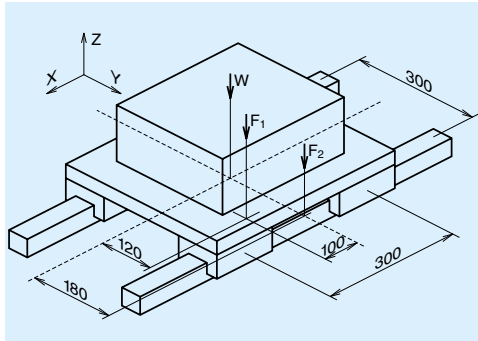

Weight and coordinates of Table W :
500N, (0, 0, —)

Weight and coordinates of Weight F₁:
2500N, (100, 120, —)

Weight and coordinates of Weight F₂:
1000N, (0, 180, —)

Since the above is all vertical load, we do not consider Z axis coordinates.

Therefore, the formula "(A) When vertical load is applied" is:

$$K_{p0} = \frac{|X_0|}{L_b} + \frac{|Y_0|}{L_r} = \frac{0}{300} + \frac{0}{300} = 0$$

(1) Also $K_{p1} = \frac{100}{300} + \frac{120}{300} = 0.73$

$$K_{p2} = \frac{0}{300} + \frac{180}{300} = 0.6$$

obtain the load per ball slide P using formula (3.1) as follows.

$$\begin{aligned} P &= \sum \frac{F}{4} + \sum \frac{K_p \cdot F}{2} \\ &= \frac{W + F_1 + F_2}{4} + \frac{K_{p0} \cdot W + K_{p1} \cdot F_1 + K_{p2} \cdot F_2}{2} \\ &= \frac{500 + 2500 + 1000}{4} \\ &\quad + \frac{0 \times 500 + 0.73 \times 2500 + 0.6 \times 1000}{2} \\ &= 2212.5 \text{ (N)} \end{aligned}$$

The appropriate size is around 30 for LH, LS, and LY types according to Fig. I-3.4. Confirm the size (Model number) in "A-I-5 Model Number and Dimension Table." The correct linear guide size is LH30AN. Calculate the life expectancy using "A-II-3.2 How to Calculate Life."

$$\begin{aligned} L &= 50 \times \left(\frac{f_h \cdot C}{f_w \cdot F_m} \right)^3 \\ &= 50 \times \left(\frac{1 \times 31000}{1.2 \times 2212.5} \right)^3 \\ &= 79590 \text{ km} \end{aligned}$$

Under the condition that:

- f_h : Hardness coefficient — 1
- f_w : Load coefficient — 1.2
- C : Basic dynamic load rating — LH30AN=31000N
- F_m : P=2212.5N

A-I-3.4 Accuracy and Preload

(1) Accuracy grades and types of preload

① Accuracy grades

- The accuracy grade which matches the characteristic of each series is set for NSK linear guides.
- Table I-3•1 shows accuracy grade set for each series.
- See Page A153 for accuracy specifications of each

series.

- Refer to "(2) Application examples of accuracy grades and preload" which shows cases of appropriate accuracy grade and preload type for specific purpose.

Table I-3•1 Accuracy grades and applicable series

Series	Preloaded assembly (non-interchangeable)					Interchangeable assembly
	Ultra precision	Super precision	High precision	Precision	Normal grade	Normal grade
	P3	P4	P5	P6	PN	PC
LH, SH	○	○	○	○	○	○
LS, SS	○	○	○	○	○	○
LA	○	○	○	○		
LY	○	○	○	○		
LW			○	○	○	○
LE			○	○	○	○
LU		○	○	○	○	○
LL					○	

② Preload

- Several types of preload that match the characteristic of each series are set for NSK linear guides.
- Types of preload for each series are shown in Table I-3-2.

- Radial clearance, preload, and rigidity of each series are shown in Page A155.
- "(2) Application examples of accuracy grade and preload" show cases of appropriate preload and accuracy grades for specific purposes.

Table I-3-2 Classification of preload

Series	Preloaded assembly (non-interchangeable)					Interchangeable assembly	
	Heavy preload	Medium preload	Light preload	Slight preload	Fine clearance	Slight preload	Fine clearance
	Z4	Z3	Z2	Z1	Z0	ZZ	ZT
LH, LS		○		○	○	○	○
SH, SS		○		○	○	○	
LA	○	○					
LY	○	○	○	○	○		
LW		(○)		○	○	○	○
LE				○	○		○
LU				○	○		○
LL					○		

Note: • Z3 preload types for LW Series are LW35, 50 only.
• "Z" is omitted from the specification number (See A-I-4.1).

③ Combinations of accuracy grade and preload

- Combinations of accuracy grade and preload are shown in Table I-3-3.

Table I-3-3 Combinations of accuracy grade and preload type

	Accuracy grade	Preload
Preloaded assembly	P3~P6	Z4~Z0
	PN	Z1, Z0
Interchangeable assembly	PC	ZZ, ZT

(2) Application examples of accuracy grade and preload

Table I-3.4 shows examples of accuracy grade and preload" of NSK linear guides for specific purposes. Refer to this table when selecting accuracy grade and preload type for your application.

Table I-3-4 Examples of accuracy grade and preload for specific purpose

Type of machine	Application	Accuracy grade					Preload				
		Ultra precision P3	Super precision P4	High precision P5	Precision P6	Normal grade PN, PC	Heavy preload Z4	Medium preload Z3	Light preload Z2	Slight preload Z1, ZZ	Fine clearance Z0, ZT
Machine tools	• Machining centers		○	○	○		○	○			
	• Grinders	○	○	○			○	○	○		
	• Lathes		○	○	○		○	○			
	• Milling machines		○	○	○		○	○			
	• Drilling machines			○	○		○	○			
	• Boring machines		○	○	○		○	○			
	• Gear cutters		○	○	○		○	○	○		
	• Diesinking machine		○	○	○			○	○	○	
	• Laser cutting machine		○	○	○			○	○	○	
	• Electric discharge machine	○	○	○			○	○			
Industrial machines and equipment	• Punch press			○	○			○	○	○	
	• Press machine				○	○			○	○	○
	• Welding machine				○	○		○	○	○	○
	• Painting machine				○	○			○	○	○
	• Textile machine				○	○			○	○	○
	• Coil winder				○	○		○	○	○	○
	• Woodworking machine			○	○	○		○	○	○	○
	• Glass processing machine				○	○			○	○	○
	• Stone cutting machine				○	○			○	○	○
	• Tire forming machine				○	○			○	○	○
	• ATC				○	○			○	○	○
	• Industrial robot			○	○	○		○	○	○	○
	• Materials handling				○	○			○	○	○
	• Packing machine				○	○			○	○	○
	• Construction machine					○				○	○
Semiconductor facilities	• Prober	○						○	○	○	
	• Wire bonder		○	○				○	○	○	
	• PCB driller			○	○			○	○	○	
	• Slicer	○	○						○		
	• Dicer	○	○						○		
	• Chip mounter			○	○			○	○	○	
	• IC handler			○	○				○	○	
• Scanner			○	○				○	○		
Others	• Lithographic machine	○	○					○	○	○	
	• Measuring / inspection equipment	○	○	○	○				○	○	
	• Three-dimensional measuring equipment	○	○	○	○			○	○	○	
	• Medical equipment		○	○	○				○	○	○
	• OA equipment				○	○				○	○
	• Railway cars					○				○	○
	• Stage systems					○				○	○
• Pneumatic equipment				○	○				○	○	

Only "slight preload (Z1, ZZ)" and "fine clearance (Z0, ZT)" are available for normal grade (PN and PC). For interchangeable type, only accuracy grade "PC," and preload (ZZ) and (ZT) are available. Refer to Page A151 for the explanation of accuracy grade and preload.

A-I-3.5 Available Length of Rail (single rail)

- Table I-3•5 and Table I-3•6 show the limitations of rail length (maximum length). However, the limitations vary by accuracy grade.

Table-I-3•5 Limitations of rail length (single rail) Unit : mm

Series	Size		05	07	09	12	15	20	25	30	35	45	55	65	85
	Material														
LH SH	Special high carbon steel						2000	3960	3960	4000	4000	3990	3960	3900	2520
	Stainless steel						1800	3500	3500	3500					
LS SS	Special high carbon steel						2000	3960	3960	4000	4000				
	Stainless steel						1800	3500	3500	3500	3500				
LA	Special high carbon steel								3960	4000	4000	3990	3960	3900	
LY	Special high carbon steel						2000	2000	2200	3000	3000	3700	3000	3000	
LE	Stainless steel	150	600	800	1000	1200									
LU	Special high carbon steel			1200	1800	2000									
	Stainless steel	210	375	600	800	1000									

Table-I-3•6 Length limitations of LW Series rails Unit : mm

Series	Size		17	21	27	35	50
	Material						
LW	Special high carbon steel		1000	1600	2000	2400	3000

- Rails can be butted if user requirement exceeds the rail length shown in the Table. Please consult NSK.
- Rails for butting connection are available for LH and LS interchangeable rails. Please consult with NSK.

A-I-4 Coding for Reference Number of Linear Guides

When inquiring about or ordering linear guide products from the catalog, please use the reference number of the coding system detailed below. Please omit the design serial number (-**) as this is an internal NSK code that is assigned after a design is created for an application. Once an order is placed, the product reference number and design serial number are combined into the final part number.

A matched set of assemblies is a set of rails and slider blocks where the rails and slider blocks are ground simultaneously to ensure matching assembly height tolerances depending on the accuracy grade required. If you would like to order a matched set, be sure to indicate as such by including the "-II" with your reference number.

1. Preloaded assembly

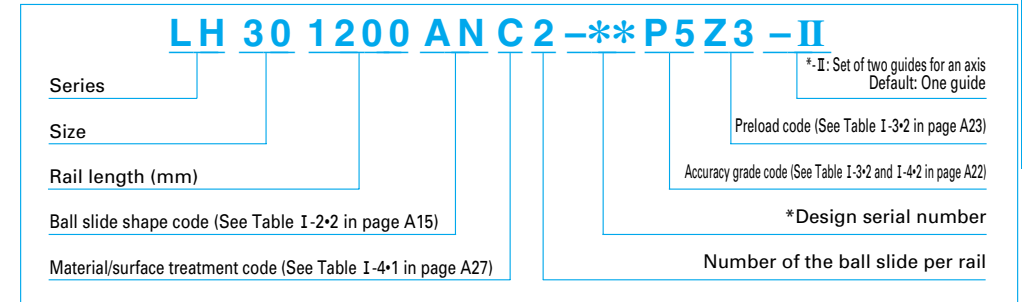

* Please note that we assign the design number, and omit the last code (II) that indicates a use of two rails as a set to finalize the reference number as product identification.

2. Interchangeable type

Interchangeable rails and ball slides for random matching are available for LH, LS, SH, SS, LE, LU, and LW series. The rails and ball slides may be purchased separately.

(1) Reference number coding for assembled rail and ball slide

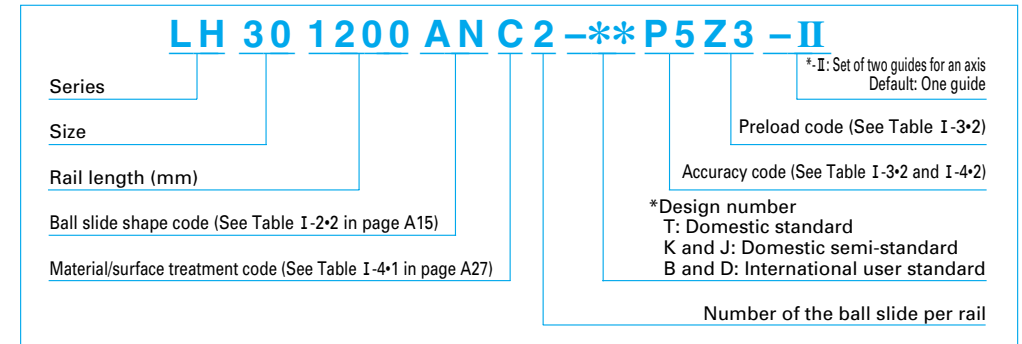

* Please note that we assign the design number, and omit the last code (II) that indicates a use of two rails as a set to finalize the reference number as product identification.