

A-5-2.1 RA Series



(1) Features

1. Super-high load capacity

By installing rollers that are the largest possible diameter and length within the existing standard cross-section dimension in a rational layout based on analysis technology, we have realized the world's highest load capacity,\* far superior to conventional roller guides. Super-long life is achieved and impact load can be sufficiently handled.

\* Compared with products of the same size, as of September 1, 2003, researched by NSK.

2. Super-high rigidity

Using NSK's advanced analysis technology, we pursued a complete, optimal design, down to the detailed shape of roller slides and rails, thereby realizing super-high rigidity superior to that of competitor's roller guides.

3. Super-high motion accuracy

NSK has developed its own unique method of simulating rolling element passage vibration and method of designing optimal roller slide specifications for damping roller passage vibration. These developments have dramatically enhanced roller slide motion accuracy for the RA series.

4. Smooth motion

Installing a retaining piece between rollers and restraining the skew peculiar to roller bearings achieve smooth motion.

5. Low friction

Using rollers for rolling elements helps minimize dynamic friction.

6. Fast delivery

Lineup of random-matching rails and roller slides supports random matching and facilitates fast delivery. (RA25 to RA65)

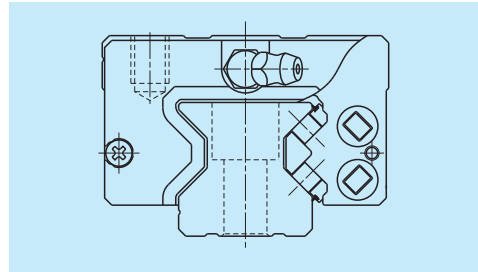

Fig. 1 RA Series

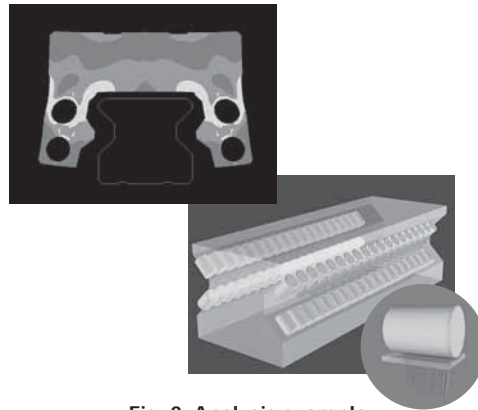

Fig. 2 Analysis example

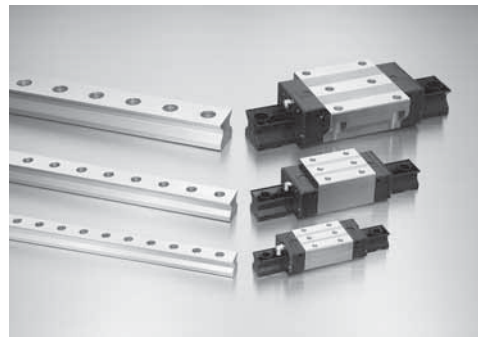

Fig. 3 Random-matching type

(2) Roller slide shape

Roller slide Model	Shape/installation method	Type	
		High-load type	Super-high-load type
AN BN		AN 	BN 
AL BL		AL 	BL 
EM GM		EM 	GM 

(3) Accuracy and preload

1. Running parallelism of roller slide

Table 1

Unit: μm

Rail over all length (mm) over or less	Preloaded assembly			Random-matching type
	Ultra precision P3	Super precision P4	High precision P5	Precision grade P6
- 50	2	2	2	4.5
50 - 80	2	2	3	5
80 - 125	2	2	3.5	5.5
125 - 200	2	2	4	6
200 - 250	2	2.5	5	7
250 - 315	2	2.5	5	8
315 - 400	2	3	6	9
400 - 500	2	3	6	10
500 - 630	2	3.5	7	12
630 - 800	2	4	8	14
800 - 1 000	2.5	4.5	9	16
1 000 - 1 250	3	5	10	17
1 250 - 1 600	4	6	11	19
1 600 - 2 000	4.5	7	13	21
2 000 - 2 500	5	8	15	22
2 500 - 3 150	6	9.5	17	25
3 150 - 3 500	9	16	23	30

2. Accuracy standard

The preloaded assembly has four accuracy grades; Ultra precision P3, Super precision P4, High precision P5, and Precision P6 grades, while the random-matching type has Precision P6 grade.

• Tolerance of preloaded assembly

Table 2 Unit:  $\mu\text{m}$

Accuracy grade	Ultra precision P3	Super precision P4	High precision P5	Precision grade P6
Characteristics				
Mounting height $H$	$\pm 8$	$\pm 10$	$\pm 20$	$\pm 40$
Variation of $H$ (All roller slides on a set of rails)	3	5	7	15
Mounting width $W_2$ or $W_3$	$\pm 10$	$\pm 15$	$\pm 25$	$\pm 50$
Variation of $W_2$ or $W_3$ (All roller slides on reference rail)	3	7	10	20
Running parallelism of face C to face A Running parallelism of face D to face B	Shown in Table 1 and Fig. 4			

• Tolerance of random-matching type

Table 3 Unit:  $\mu\text{m}$

Accuracy grade	Random-matching with precision grade P6
Characteristics	
Mounting height $H$	$\pm 20$
Variation of mounting height $H$	15① 30②
Mounting width $W_2$ or $W_3$	$\pm 25$
Variation of mounting width $W_2$ or $W_3$	20
Running parallelism of face C to face A Running parallelism of face D to face B	See Table 1 and Fig. 4

Note: ① Variation on the same rail ② Variation on multiple rails

3. Assembled accuracy

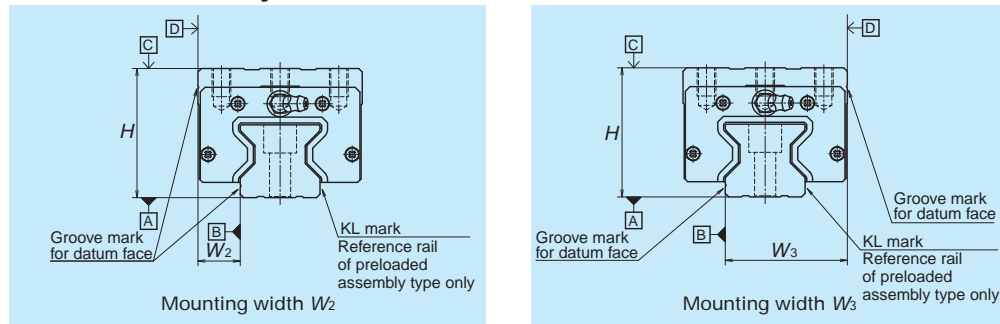

Fig. 4

4. Preload and rigidity

Preload is set for the RA series by slightly changing the size of the roller used. Applying preload enhances rigidity and minimizes elastic deformation.

With the characteristics of the roller guide, there is minimal variation in rigidity according to amount of preload, and it offers stable, high rigidity. Because of that, for the RA series, only medium preload type Z3 (preload: 10% of  $C$ , where  $C$  is the basic dynamic load rating) is set. Preload is shown in Table 4, and theoretical rigidity lines are shown in Fig. 6 and Fig. 7.

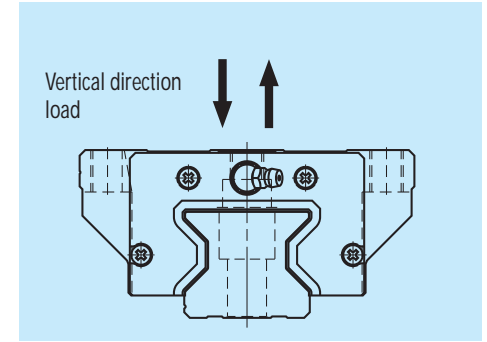

Fig. 5 Direction of load

Table 4 Preload Unit: N

Model No.	High-load type Medium preload (Z3)	Super-high-load type Medium preload (Z3)
RA15	1 030	1 300
RA20	1 920	2 400
RA25	2 920	3 540
RA30	3 890	4 760
RA35	5 330	6 740
RA45	9 280	11 600
RA55	12 900	16 800
RA65	21 000	28 800

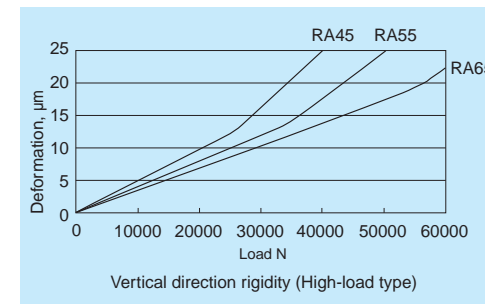
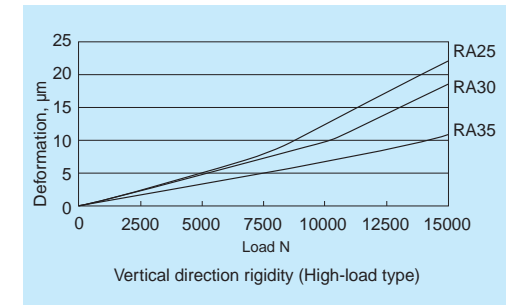
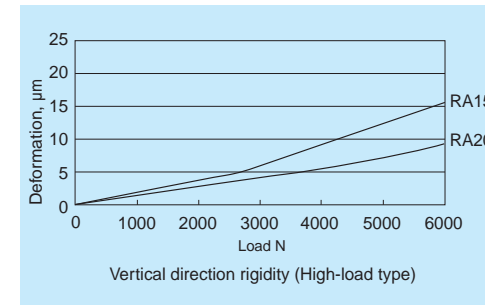

Fig. 6 Vertical direction theoretical rigidity line: High-load type (Roller slide shape: AN, AL, EM)

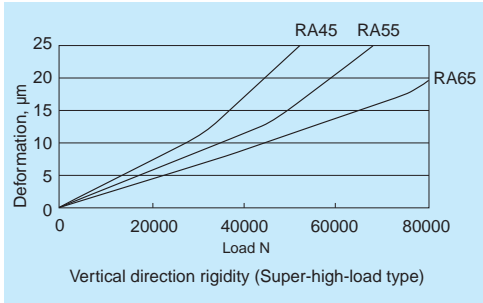
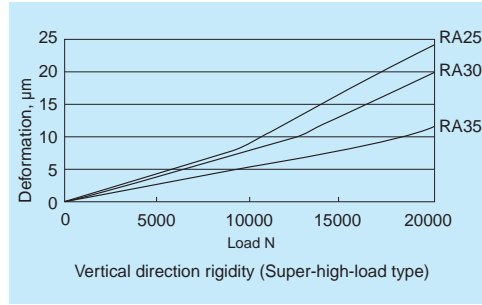
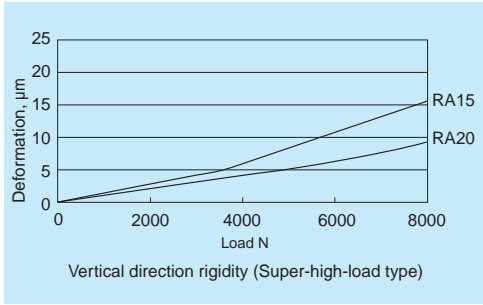

Fig. 7 Vertical direction theoretical rigidity line: Super-high-load type (Roller slide shape: BN, BL, GM)

(4) Available length of rail

Table 5 shows the limitations of rail length (maximum length). However, the limitations vary by accuracy grade.

**Table 5 Length limitation of rails** Unit : mm

Series	Size	RA15	RA20	RA25	RA30	RA35	RA45	RA55	RA65
RA		2000	3000	3000	3500	3500	3500	3500	3500

Note: Rails can be butted if user requirement exceeds the rail length shown in the Table. Please consult NSK.

(5) Installation

1. Permissible values of mounting error

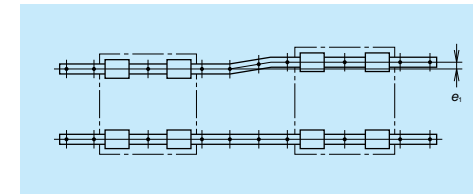

Fig. 8

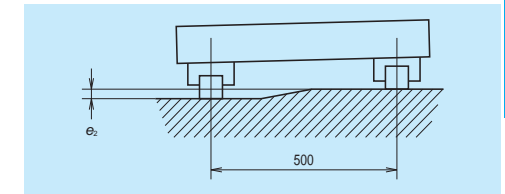

Fig. 9

**Table 6** Unit :  $\mu\text{m}$

Value	Preload	Model No.							
		RA15	RA20	RA25	RA30	RA35	RA45	RA55	RA65
Permissible values of parallelism in two rails $e_1$	Z3	5	7	9	11	13	17	19	30
Permissible values of parallelism (height) in two rails $e_2$	Z3	150 $\mu\text{m}$ /500 mm							

2. Shoulder height of the mounting face and corner radius r

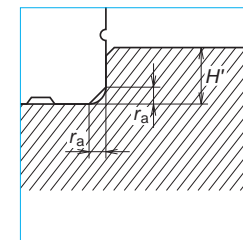

Fig. 10 Shoulder for the rail datum face

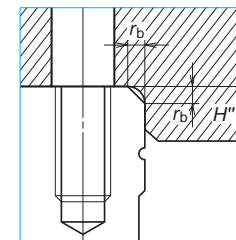

Fig. 11 Shoulder for the roller slide datum face

**Table 7** Unit : mm

Model No.	Corner radius (maximum)		Shoulder height	
	$r_a$	$r_b$	$H'$	$H''$
RA15	0.5	0.5	3	4
RA20	0.5	0.5	4	5
RA25	0.5	1	4	5
RA30	1	1	5	6
RA35	1	1	5	6
RA45	1.5	1	6	8
RA55	1.5	1.5	7	10
RA65	1.5	1.5	11	11

(6) Lubrication components

Refer to page A38 and D13 for the lubrication of linear guides.

1. Types of lubrication accessories

Figure 14 and Table 10 show grease fittings and tube fittings.

2. Mounting position of lubrication accessories

The standard position of grease fittings is the end face of roller slide. We mount them on a side of end cap for an option. (Fig. 12) Mounting positions are shown in Fig.12, 13, Table 8 and 9.

Please consult NSK for installation of grease or tube fittings to the roller slide body or side of end cap.

When using a piping unit with thread of M6×1, you require a connector to connect to a grease fitting mounting hole with M6 × 0.75. The connector is available from NSK.

A lubrication hole can also be provided on the top of the end cap. Fig.13, Table 8 and 9 show the mounting position.

A spacer is required for AN and BN type of roller slides.

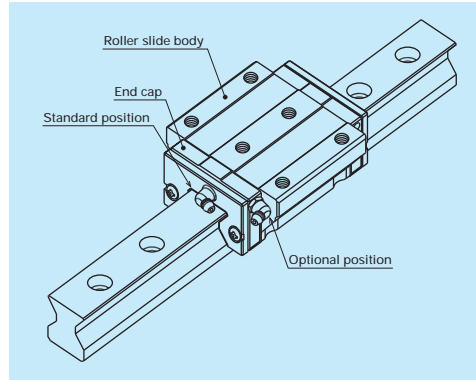

Fig. 12 Mounting position of lubrication accessories

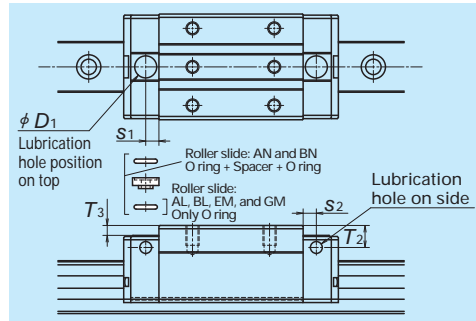

Fig.13 Top and side lubrication hole positions

Table 8 Top and side lubrication hole positions Unit: mm

Model No.	Roller slide shape code	Grease fitting size	$s_2$	$T_2$	O ring (JIS)	Spacer	$D_1$	$s_1$	$T_3$
RA15	AN, BN	$\phi 3$	4	7	P5	Necessary	8.2	4.4	4.2
RA20		$\phi 3$	4	4	P6	—	9.2	5.4	0.2
RA25		M6×0.75	6	10	P7	Necessary	10.2	6	4.5
RA30		M6×0.75	5	10	P7	Necessary	10.2	6	3.5
RA35		M6×0.75	5.5	15	P7	Necessary	10.2	7	7.4
RA45		Rc 1/8	7.2	20	P7	Necessary	10.2	7.2	10.4
RA55		Rc 1/8	7.2	21	P7	Necessary	10.2	7.2	10.4
RA65		Rc 1/8	7.2	19	P7	—	10.2	7.2	0.4

Table 9 Top and side lubrication hole positions Unit: mm

Model No.	Roller slide shape code	Grease fitting size	$s_2$	$T_2$	O ring (JIS)	$D_1$	$s_1$	$T_3$
RA15	AL, BL, EM, GM	$\phi 3$	4	3	P5	8.2	4.4	0.2
RA20	EM, GM	$\phi 3$	4	4	P6	9.2	5.4	0.2
RA25	AL, BL, EM, GM	M6×0.75	6	6	P7	10.2	6	0.4
RA30		M6×0.75	5	7	P7	10.2	6	0.4
RA35		M6×0.75	5.5	8	P7	10.2	7	0.4
RA45		Rc 1/8	7.2	10	P7	10.2	7.2	0.4
RA55		Rc 1/8	7.2	11	P7	10.2	7.2	0.4
RA65		EM, GM	Rc 1/8	7.2	19	P7	10.2	7.2

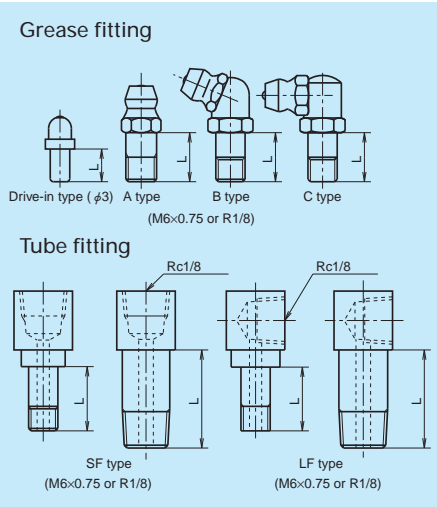

Fig. 14 Grease fitting and tube fitting

(7) Dust proof components

1. Standard specification

RA series is equipped with end, inner\* and bottom seals to prevent foreign matter from entering the inside of the roller slide. Under normal applications, the RA series can be used without modification.

For severe usage conditions, optional rail covers\*\* are available. Contact NSK for information on how to mount the cover.

\*) Inner seals for RA15 and RA20 are available as options.

\*\*\*) Rail cover is applicable to RA25 to RA65.

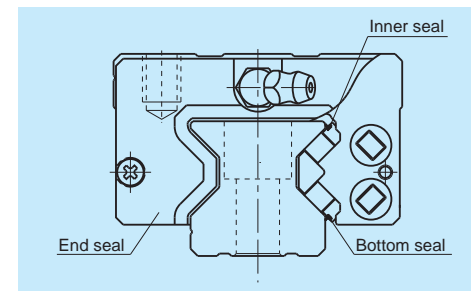

Fig. 15



Fig. 16 Rail cover

Table 11 Seal friction per roller slide (maximum value)

Series	Size	Unit : N							
		15	20	25	30	35	45	55	65
RA		4	5.5	5	5	6	8	8	14

Table 10 Unit: mm

Model No.	Dust-proof specification	Grease fitting	Tube fitting
		Drive-in fitting Thread body length L	Thread body length L
RA15	Standard	5	—
	With NSK K1	10	—
	Double seal	8	—
	Protector	8	—
RA20	Standard	5	—
	With NSK K1	10	—
	Double seal	8	—
	Protector	10	—
RA25	Standard	5	5
	With NSK K1	12	12
	Double seal	10	9
	Protector	10	9
RA30	Standard	5	6
	With NSK K1	14	15
	Double seal	12	11
	Protector	12	11
RA35	Standard	5	6
	With NSK K1	14	15
	Double seal	12	11
	Protector	12	11
RA45	Standard	8	17
	With NSK K1	18	21.5
	Double seal	14	17
	Protector	14	17
RA55	Standard	8	17
	With NSK K1	18	21.5
	Double seal	14	17
	Protector	14	17
RA65	Standard	8	17
	With NSK K1	20	20
	Double seal	14	17
	Protector	14	17

2. NSK K1™

Table 12 shows the dimension of linear guides equipped with the NSK K1.

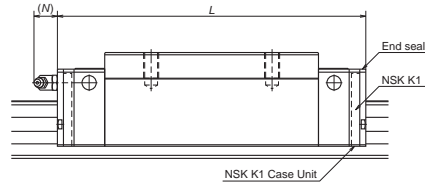

Table 12

Unit: mm

Model No.	Roller slide length	Roller slide model	Standard roller slide length	Roller slide length installed with NSK K1 Case Unit L	Per NSK K1 case unit thickness	Protruding area of the grease fitting N
RA15	Standard	AN, AL, EM	70	79	4.5	(3)
	Long	BN, BL, GM	85.4	94.4		
RA20	Standard	AN, EM	86.5	95.5	4.5	(3)
	Long	BN, GM	106.3	115.3		
RA25	Standard	AN, AL, EM	97.5	107.5	5	(11)
	Long	BN, BL, GM	115.5	125.5		
RA30	Standard	AN, AL, EM	110.8	122.8	6	(11)
	Long	BN, BL, GM	135.4	147.4		
RA35	Standard	AN, AL, EM	123.8	136.8	6.5	(11)
	Long	BN, BL, GM	152	165		
RA45	Standard	AN, AL, EM	154	168	7	(14)
	Long	BN, BL, GM	190	204		
RA55	Standard	AN, AL, EM	184	198	7	(14)
	Long	BN, BL, GM	234	248		
RA65	Standard	AN, EM	228.4	243.4	7.5	(14)
	Long	BN, GM	317.5	317.5		

Roller slide length equipped with NSK K1 case unit = (Standard roller slide length) + (Thickness of NSK K1 case unit × Number of NSK K1 case unit)

3. Double seal and protector

For RA Series, double seal and protector can be installed only before shipping from the factory. Table 13 shows the increased thickness when end seal and protector are installed.

Table 13

Model No.	Thickness of end seal	Thickness of protector
RA15	3	2.7
RA20	3	3.3
RA25	3.2	3.3
RA30	3.4	3.6
RA35	3.4	3.6
RA45	4	4.2
RA55	4	4.2
RA65	5	5.5

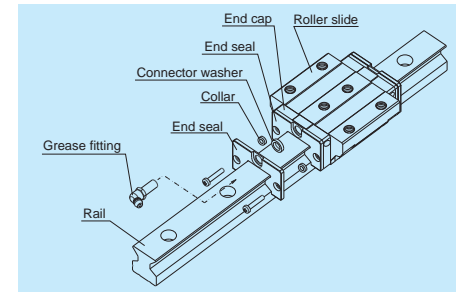

Fig. 17 Double seal

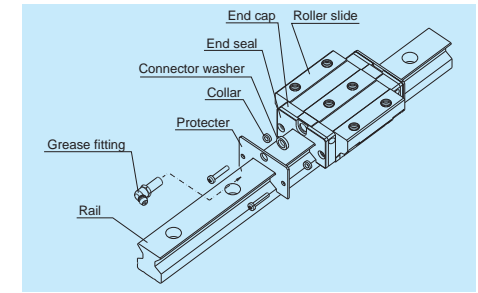

Fig. 18 Protector

4. Rail cover

When the rail cover is used, use the cover bracket to secure the rail cover. Fig.19 shows the dimensions for the cover bracket. The required room at the end of the rail is:

- Inside: 10.5 mm or less
  - Outside: 4 mm or less (Common to the models of RA25 to 65)
- Please confirm the interference with your machine at the stroke end.
- Machine stroke
  - Room for the end of the rail

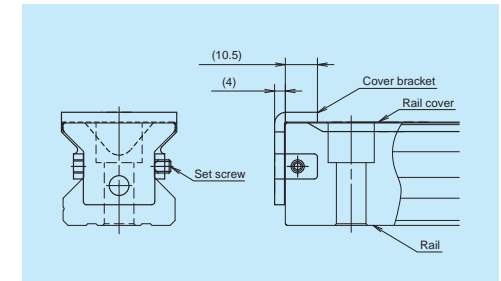

Fig. 19 End configuration of rail equipped with the rail cover

The height of the rail with the rail cover is shown in Table 14.

Table 14 Height of rails equipped with rail cover  
Unit: mm

Model No.	Standard height H <sub>i</sub>	Cover installation
RA25	24	24.25
RA30	28	28.25
RA35	31	31.25
RA45	38	38.3
RA55	43.5	43.8
RA65	55	55.3

5. Cap to cover the bolt hole for rail mounting

Table 15 Caps to cover rail bolt hole

Model No.	Bolt to secure rail	Cap reference No.	Quantity /case
RA15	M4	LG-CAP/M4	20
RA20	M5	LG-CAP/M5	20
RA25	M6	LG-CAP/M6	20
RA30, RA35	M8	LG-CAP/M8	20
RA45	M12	LG-CAP/M12	20
RA55	M14	LG-CAP/M14	20
RA65	M16	LG-CAP/M16	20

**(8) Reference number**

Reference numbers shall be set to individual NSK linear guide when its specifications are finalized, and it is indicated on its specification drawing.

Please specify the reference number, except design serial number, to identify the product when ordering, requiring estimates, or inquiring about specifications from NSK.

**1. Reference number for preloaded assembly**

**RA 35 1000 ANC 2 -\*\* P6 3**

Series name	RA	Size	35	Rail length (mm)	1000	Roller slide shape code (See page A252)	ANC	Accuracy code (See Table 17)	2	Design serial number	-**	Preload code (See page A254)	P6	Number of roller slides per rail	3
-------------	----	------	----	------------------	------	---	-----	------------------------------	---	----------------------	-----	------------------------------	----	----------------------------------	---

Added to the reference number.

**2. Reference number for random-matching type**

**Roller slide**

**RAA 35 ANC -\*\*P6 Z**

Random-matching roller slide series code RAA: RA Series random-matching roller slide	RAA	Size	35	Roller slide shape code (See page A252)	ANC	Accuracy code	-**	Preload code : Z Z: Medium preload is only available	P6	Design serial number	Z
---	-----	------	----	---	-----	---------------	-----	---	----	----------------------	---

Added to the reference number.

**Rail**

**R1A30 1000 LCN -\*\* P6 Z**

Random-matching rail series code R1A : RA Series random-matching rail	R1A	Size	30	Rail length (mm)	1000	Rail shape code: L L : Standard	LCN	Accuracy code	-**	Preload code : Z Z: Medium preload is only available	P6	Design serial number	Z
--	-----	------	----	------------------	------	------------------------------------	-----	---------------	-----	---	----	----------------------	---

Added to the reference number.

\*Butting rail specification  
N: Non-butting. L: Butting specification

\*Please consult with NSK for butting rail specification.

Reference number for assembly of random-matching roller slide and rail is the same as the coding of preloaded assembly. However, preload code is medium preload "Z".

**Table 16 Material/surface treatment code**

Code	Description
C	Special high carbon steel (NSK standard)
D	Special high carbon steel with surface treatment
Z	Other, special

**Table 17 Accuracy code**

Accuracy	Standard (Without NSK K1)	With NSK K1
Ultra precision grade	P3	K3
Super precision grade	P4	K4
High precision grade	P5	K5
Precision grade	P6	K6

Note: Refer to Page A38 for NSK K1 lubrication unit.

(9) Dimensions

RA-AN (High-load type)

RA-BN (Super-high-load type)

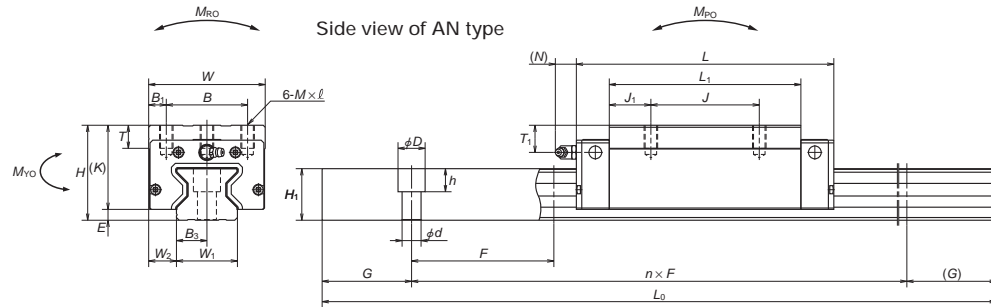
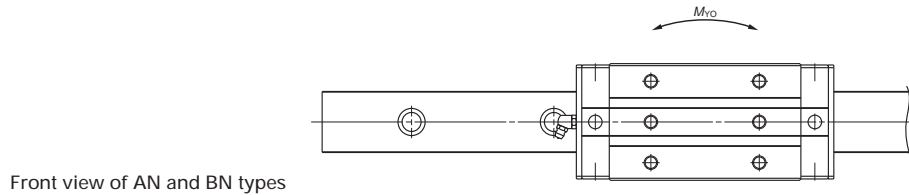
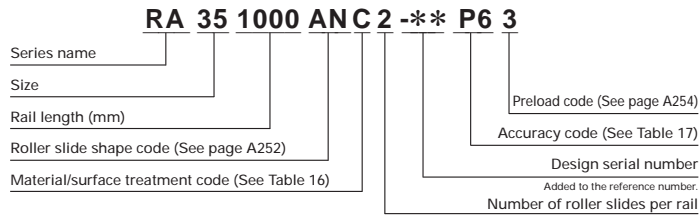

Model No.	Assembly			Roller slide													
	Height		Width	Length	Mounting hole					Grease fitting							
	H	E			W <sub>2</sub>	W	L	B	J	M × pitch × ℓ	B <sub>1</sub>	L <sub>1</sub>	J <sub>1</sub>	K	T	Hole size	T <sub>1</sub>
RA15AN RA15BN	28	4	9.5	34	70 85.4	26	26	M4×0.7×6	4	44.8 60.2	9.4 17.1	24	8	φ3	8	3	
RA20AN RA20BN	30	5	12	44	86.5 106.3	32	36	M5×0.8×6	6	57.5 77.3	10.75 13.65	25	12	φ3	4	3	
RA25AN RA25BN	40	5	12.5	48	97.5 115.5	35	35	M6×1×9	6.5	65.5 83.5	15.25 16.75	35	12	M6×0.75	10	11	
RA30AN RA30BN	45	6.5	16	60	110.8 135.4	40	40	M8×1.25×11	10	74 98.6	17 19.3	38.5	14	M6×0.75	10	11	
RA35AN RA35BN	55	6.5	18	70	123.8 152	50	50	M8×1.25×12	10	83.2 111.4	16.6 19.7	48.5	15	M6×0.75	15	11	
RA45AN RA45BN	70	8	20.5	86	154 190	60	60	M10×1.5×17	13	105.4 141.4	22.7 30.7	62	17	Rc1/8	20	14	
RA55AN RA55BN	80	9	23.5	100	184 234	75	75	M12×1.75×18	12.5	128 178	26.5 41.5	71	18	Rc1/8	21	14	
RA65AN RA65BN	90	13	31.5	126	228.4 302.5	76	76	M16×2×20	25	155.4 229.5	42.7 54.75	77	22	Rc1/8	19	14	

Remarks: 1) Select either one of dimensions for pitch of holes for rail fixing F without parenthesis for standard dimension and with parenthesis for semi-standard dimension.

Reference number for roller slide of random-matching type

Roller slide **RAA 35 AN C -\*\* P6 Z**

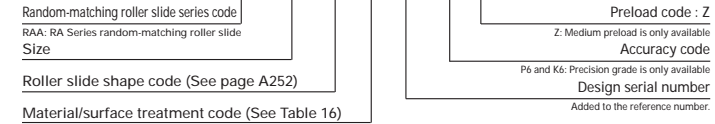

AN and BN types

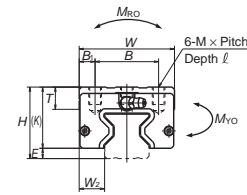

AN type

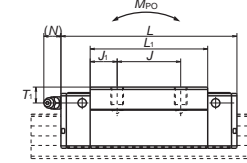

BN type

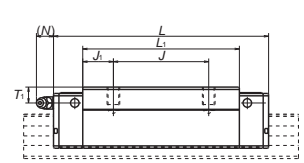

Reference number for rail of random-matching type

Rail **R1A30 1000 LCN -\*\* P6 Z**

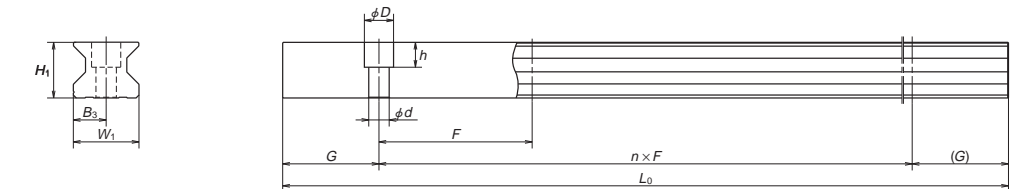
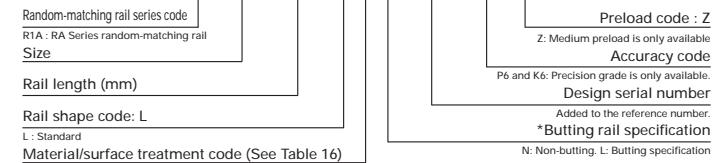

Rail							Basic load rating					Weight	
Width	Height	Pitch	Mounting bolt hole	B <sub>3</sub>	G	Maximum length L <sub>0max</sub>	Dynamic C (N)	Static C <sub>0</sub> (N)	Static moment			Roller slide (kg)	Rail (kg/m)
									M <sub>ro</sub> (N·m)	M <sub>po</sub> (N·m)	M <sub>yo</sub> (N·m)		
15	16.3	60 (30)	4.5×7.5×5.3	7.5	20	2 000	10 300 13 000	27 500 37 000	260 350	210 375	210 375	0.21 0.30	1.6
20	20.8	60 (30)	6×9.5×8.5	10	20	3 000	19 200 24 000	52 500 70 000	665 890	505 900	505 900	0.38 0.50	2.6
23	24	30	7×11×9	11.5	20	3 000	29 200 35 400	72 700 92 900	970 1 240	760 1 240	760 1 240	0.60 0.91	3.4
28	28	40	9×14×12	14	20	3 500	38 900 47 600	93 500 121 000	1 670 2 170	1 140 1 950	1 140 1 950	1.0 1.3	4.9
34	31	40	9×14×12	17	20	3 500	53 300 67 400	129 000 175 000	2 810 3 810	1 800 3 250	1 800 3 250	1.6 2.1	6.8
45	38	52.5	14×20×17	22.5	22.5	3 500	92 800 116 000	229 000 305 000	6 180 8 240	4 080 7 150	4 080 7 150	3.0 4.1	10.9
53	43.5	60	16×23×20	26.5	30	3 500	129 000 168 000	330 000 462 000	10 200 14 300	7 060 13 600	7 060 13 600	4.9 6.7	14.6
63	55	75	18×26×22	31.5	35	3 500	210 000 288 000	504 000 756 000	19 200 28 700	12 700 28 600	12 700 28 600	9.3 12.2	22.0

2) RA25 to RA65 are available in random matching.  
3) The basic load rating complies with ISO standards (ISO14728-1, ISO14728-2).  
If the basic dynamic load rating (100 km rating) is converted into 50 km rating, use the following formula:  
 $C_{50km} = 1.23 \times C_{100km}$

RA-AL (High-load type)  
RA-BL (Super-high-load type)

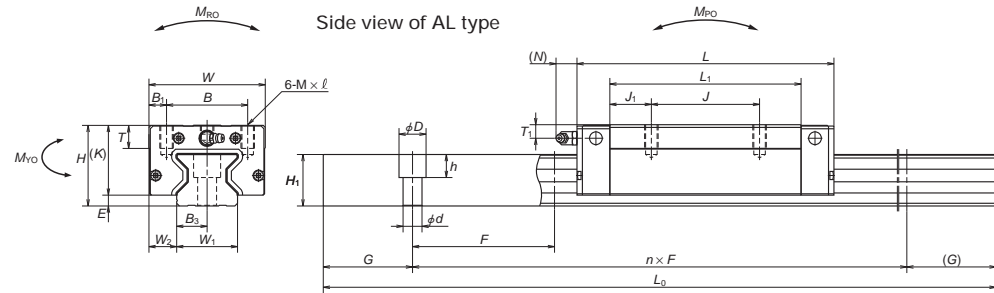
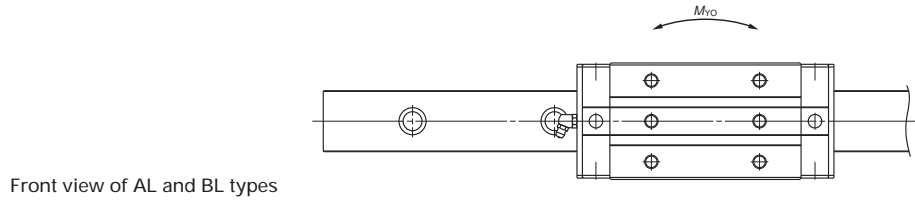
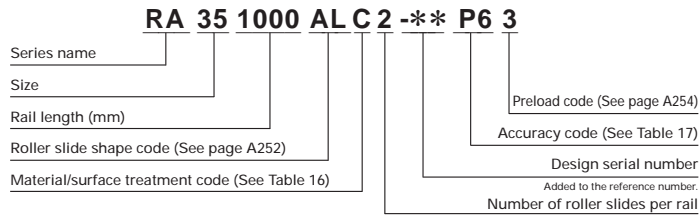

Model No.	Assembly			Roller slide												
	Height H	E	W <sub>2</sub>	Width W	Length L	Mounting hole			B <sub>1</sub>	L <sub>1</sub>	J <sub>1</sub>	K	T	Grease fitting		
						B	J	M × pitch × ℓ						Hole size	T <sub>1</sub>	N
RA15AL RA15BL	24	4	9.5	34	70 85.4	26	26	M4×0.7×5.5	4	44.8 60.2	9.4 17.1	20	8	φ3	4	3
RA25AL RA25BL	36	5	12.5	48	97.5 115.5	35	35	M6×1×8	6.5	65.5 83.5	15.25 16.75	31	12	M6×0.75	6	11
RA30AL RA30BL	42	6.5	16	60	110.8 135.4	40	40	M8×1.25×11	10	74 98.6	17 19.3	35.5	14	M6×0.75	7	11
RA35AL RA35BL	48	6.5	18	70	123.8 152	50	50	M8×1.25×12	10	83.2 111.4	16.6 19.7	41.5	15	M6×0.75	8	11
RA45AL RA45BL	60	8	20.5	86	154 190	60	60	M10×1.5×16	13	105.4 141.4	22.7 30.7	52	17	Rc1/8	10	14
RA55AL RA55BL	70	9	23.5	100	184 234	75	75	M12×1.75×18	12.5	128 178	26.5 41.5	61	18	Rc1/8	11	14

Remarks: 1) Select either one of dimensions for pitch of holes for rail fixing F without parenthesis for standard dimension and with parenthesis for semi-standard dimension.

Reference number for roller slide of random-matching type

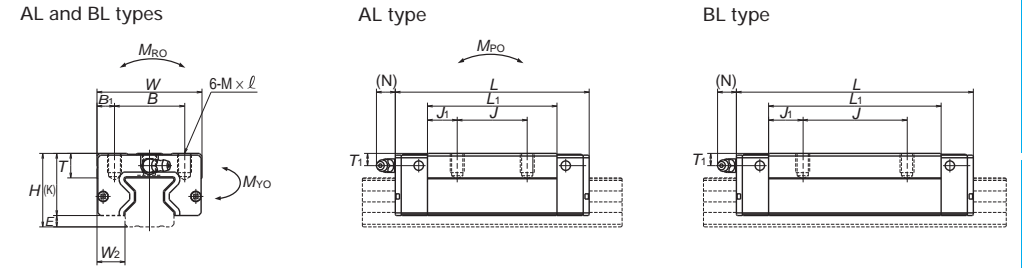
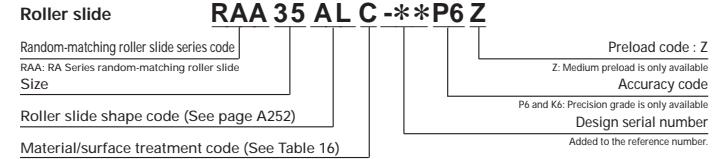

Reference number for rail of random-matching type

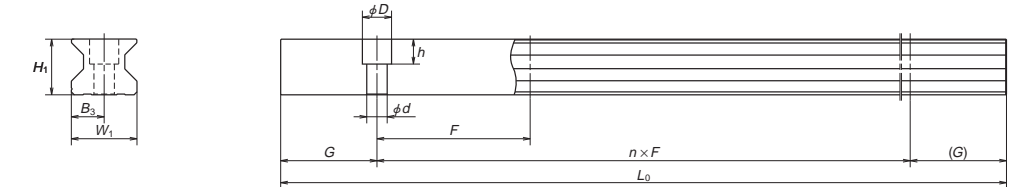
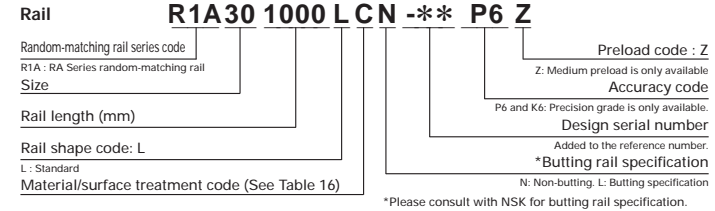

Rail							Basic load rating					Weight	
Width W <sub>1</sub>	Height H <sub>1</sub>	Pitch F	Mounting bolt hole d × D × h	B <sub>3</sub>	G (Reference)	Maximum length L <sub>0max</sub>	Dynamic C (N)	Static C <sub>0</sub> (N)	Static moment			Roller slide (kg)	Rail (kg/m)
									M <sub>RO</sub> (N-m)	M <sub>PO</sub> (N-m)	M <sub>YO</sub> (N-m)		
15	16.3	60 (30)	4.5×7.5×5.3	7.5	20	2 000	10 300 13 000	27 500 37 000	260 350	210 375	210 375	0.17 0.25	1.6
23	24	30	7×11×9	11.5	20	3 000	29 200 35 400	72 700 92 900	970 1 240	760 1 240	760 1 240	0.45 0.80	3.4
28	28	40	9×14×12	14	20	3 500	38 900 47 600	93 500 121 000	1 670 2 170	1 140 1 950	1 140 1 950	0.85 1.1	4.9
34	31	40	9×14×12	17	20	3 500	53 300 67 400	129 000 175 000	2 810 3 810	1 800 3 250	1 800 3 250	1.2 1.7	6.8
45	38	52.5	14×20×17	22.5	22.5	3 500	92 800 116 000	229 000 305 000	6 180 8 240	4 080 7 150	4 080 7 150	2.5 3.4	10.9
53	43.5	60	16×23×20	26.5	30	3 500	129 000 168 000	330 000 462 000	10 200 14 300	7 060 13 600	7 060 13 600	4.1 5.7	14.6

2) RA25 to RA55 are available in random matching.  
3) The basic load rating complies with ISO standards (ISO14728-1, ISO14728-2).  
If the basic dynamic load rating (100 km rating) is converted into 50 km rating, use the following formula:  
C<sub>50 km</sub> = 1.23 × C<sub>100 km</sub>

RA-EM (High-load type)  
RA-GM (Super-high-load type)

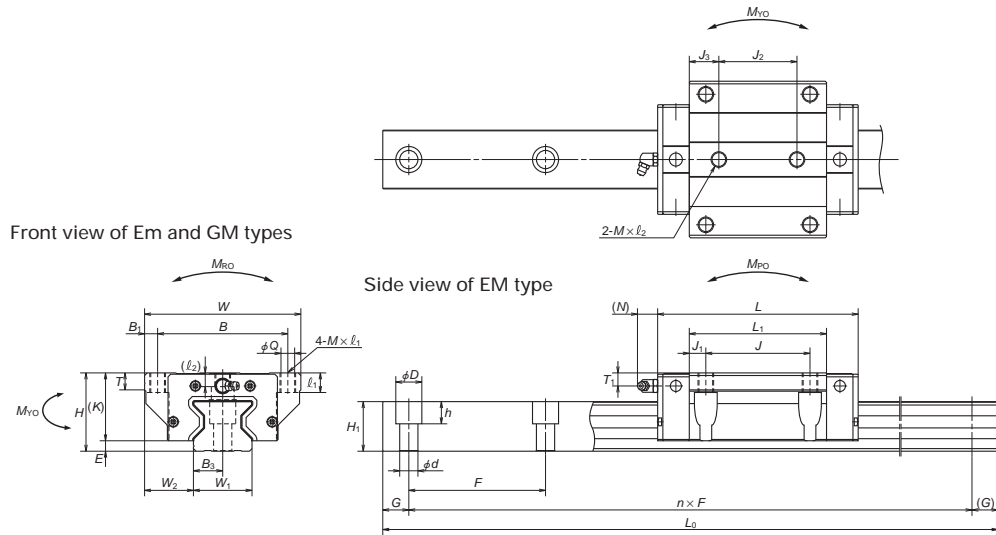
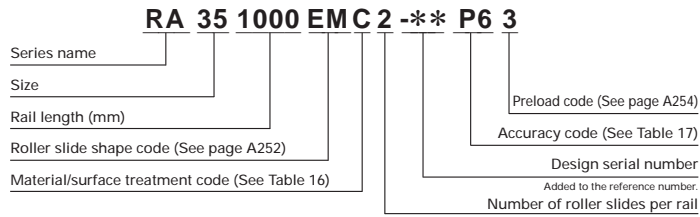

Model No.	Assembly		Roller slide															
	Height H	E	W <sub>2</sub>	Width W	Length L	Mounting hole							B <sub>1</sub>	L <sub>1</sub>	J <sub>1</sub>	J <sub>3</sub>	K	T
						B	J	J <sub>2</sub>	M × pitch × ℓ <sub>1</sub> (ℓ <sub>2</sub> )	Q <sub>2</sub>	B <sub>2</sub>	L <sub>2</sub>						
RA15EM RA15GM	24	4	16	47	70 85.4	38	30	26	M5×0.8×8.5 (6.5)	4.4	4.5	44.8 60.2	7.4 15.1	9.4 17.1	20	8		
RA20EM RA20GM	30	5	21.5	63	86.5 106.3	53	40	35	M6×1×9.5 (8)	5.3	5	57.5 77.3	8.75 18.65	11.25 21.15	25	10		
RA25EM RA25GM	36	5	23.5	70	97.5 115.5	57	45	40	M8×1.25×10 (11)	6.8	6.5	65.5 83.5	10.25 19.25	12.75 21.75	31	11		
RA30EM RA30GM	42	6.5	31	90	110.8 135.4	72	52	44	M10×1.5×12 (12.5)	8.6	9	74 98.6	11 23.3	15 27.3	35.5	11		
RA35EM RA35GM	48	6.5	33	100	123.8 152	82	62	52	M10×1.5×13 (7)	8.6	9	83.2 111.4	10.6 24.7	15.6 29.7	41.5	12		
RA45EM RA45GM	60	8	37.5	120	154 190	100	80	60	M12×1.75×15 (10.5)	10.5	10	105.4 141.4	12.7 30.7	22.7 40.7	52	13		
RA55EM RA55GM	70	9	43.5	140	184 234	116	95	70	M14×2×18 (13)	12.5	12	128 178	16.5 41.5	29 54	61	15		
RA65EM RA65GM	90	13	53.5	170	228.4 302.5	142	110	82	M16×2×24 (18.5)	14.6	14	155.4 229.5	22.7 59.75	36.7 73.75	77	22		

Remarks: 1) Select either one of dimensions for pitch of holes for rail fixing F without parenthesis for standard dimension and with parenthesis for semi-standard dimension.

Reference number for roller slide of random-matching type

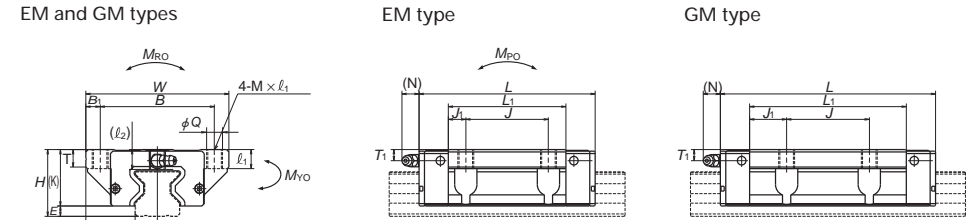
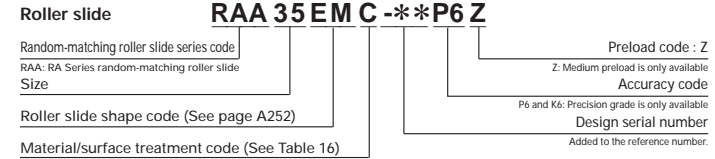

Reference number for rail of random-matching type

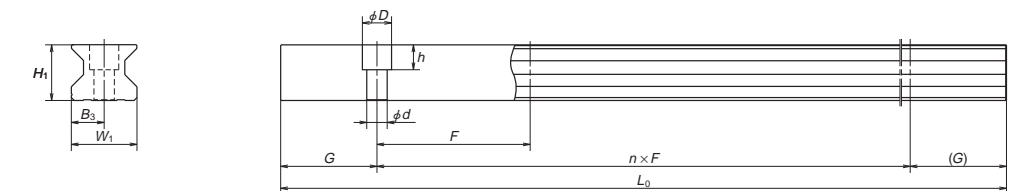
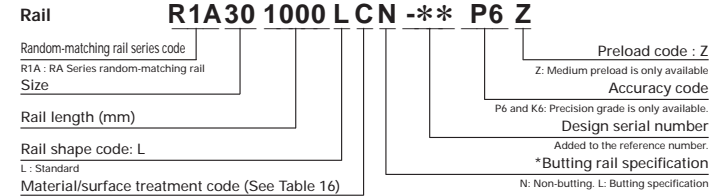

Grease fitting Hole size	T <sub>1</sub>	N	Rail										Basic load rating					Weight	
			Width W <sub>1</sub>	Height H <sub>1</sub>	Pitch F	Mounting bolt hole d × D × h	B <sub>3</sub>	G Reference	Maximum length L <sub>max</sub>	Dynamic C (N)	Static C <sub>0</sub> (N)	Static moment			Roller slide (kg)	Rail (kg/m)			
												M <sub>Ro</sub> (N-m)	M <sub>Vo</sub> (N-m)	M <sub>Vo</sub> (N-m)					
φ3	4	3	15	16.3	60 (30)	4.5×7.5×5.3	7.5	20	2 000	10 300 13 000	27 500 37 000	260 350	210 375	210 375	0.21 0.28	1.6			
φ3	4	3	20	20.8	60 (30)	6×9.5×8.5	10	20	3 000	19 200 24 000	52 500 70 000	665 890	505 900	505 900	0.45 0.65	2.6			
M6×0.75	6	11	23	24	30	7×11×9	11.5	20	3 000	29 200 35 400	72 700 92 900	970 1 240	760 1 240	760 1 240	0.80 1.1	3.4			
M6×0.75	7	11	28	28	40	9×14×12	14	20	3 500	38 900 47 600	93 500 121 000	1 670 2 170	1 140 1 950	1 140 1 950	1.3 1.7	4.9			
M6×0.75	8	11	34	31	40	9×14×12	17	20	3 500	53 300 67 400	129 000 175 000	2 810 3 810	1 800 3 250	1 800 3 250	1.7 2.3	6.8			
Rc1/8	10	14	45	38	52.5	14×20×17	22.5	22.5	3 500	92 800 116 000	229 000 305 000	6 180 8 240	4 080 7 150	4 080 7 150	3.2 4.3	10.9			
Rc1/8	11	14	53	43.5	60	16×23×20	26.5	30	3 500	129 000 168 000	330 000 462 000	10 200 14 300	7 060 13 600	7 060 13 600	5.4 7.5	14.6			
Rc1/8	19	14	63	55	75	18×26×22	31.5	35	3 500	210 000 288 000	504 000 756 000	19 200 28 700	12 700 28 600	12 700 28 600	12.2 16.5	22.0			

2) RA25 to RA65 are available in random matching.  
3) The basic load rating complies with ISO standards (ISO14728-1, ISO14728-2).  
If the basic dynamic load rating (100 km rating) is converted into 50 km rating, use the following formula:  
C<sub>50km</sub> = 1.23 × C<sub>100km</sub>