

C-I-3 Optional components

MCM Series

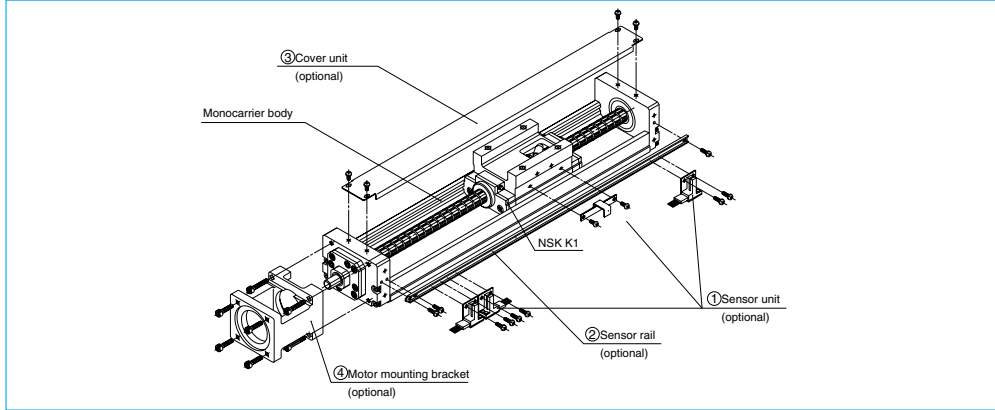

Fig.1-3 Assembly Optional components for MCM10 (example)

- ① Sensor unit : Sensors, sensor mounting parts and a sensor dog are available in a set.
※ When you used a sensor unit, the full cover unit cannot be used.
 - ② Sensor rail : Rail for sensor mounting is available.
 - ③ Cover unit : Top cover or full cover (included top cover and side cover) is available.
 - ④ Motor bracket for motor mounting : Prepared for each motor maker.
- ☆ We assemble optional components upon request.

MCH Series

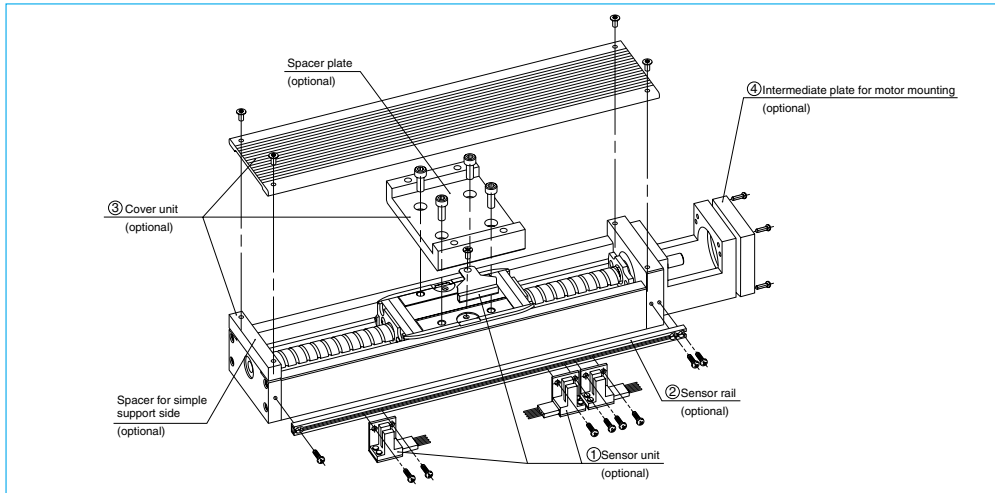

Fig. 1-4 Assembly Optional components for MCH10 (example)

- ① Sensor unit : Sensors, sensor mounting parts and a sensor dog are available in a set.
 - ② Sensor rail : Rail for sensor mounting is available.
 - ③ Cover unit : Top cover (included spacer plate and spacer for simple support side) is available.
 - ④ Intermediate plate for motor mounting : Prepared for each motor maker.
- ☆ We assemble optional components upon request.

C-I-4 Selection of Monocarrier
C-I-4.1 Procedures for selecting Monocarrier

Select a reference type of Monocarrier based on stroke and rigidity (Refer to Fig. 1-6, 1-7).



Select a ball screw lead referring to "1.4.3 Maximum Rotational Speed" so that the rotational speed does not exceed the limit.



Study the loads to be applied to the linear guide and obtain the equivalent load F_e substituting them for equation ① or ② on Page C13. Obtain the mean effective load F_m substituting them for equation ③ on Page C14, then calculate the life.



Study the loads to be applied to the ball screw and support unit. Obtain the mean effective load F_m substituting them for equation ③ on Page C14, then calculate the life.

C-I-4.2 Rigidity

Rigidity of rail

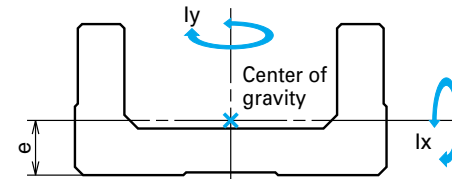

Fig. 1-5

Table 1-2 Rigidity of rail

Nominal size	Geometrical moment of inertia $\times 10^4$ (mm ⁴)		Center of gravity (mm)	Mass (kg/100mm)
	I_x	I_y	e	w
MCM02	0.097	1.32	3.3	0.11
MCM03	0.30	3.3	4.5	0.18
MCM05	0.78	11.4	6.0	0.31
MCM06	2.14	26.1	7.0	0.57
MCM08	5.90	81.0	9.2	0.88
MCM10	15.6	219	12.2	1.52
MCH06	6.5	38.2	10.8	0.67
MCL06	2.58	29.6	7.8	0.56
MCH09	28.7	172	15.5	1.48
MCH10	54.0	307	18	1.93

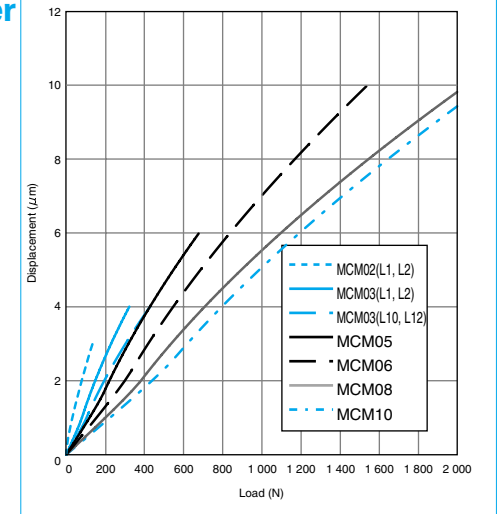

Fig. 1-6 MCM Series Rigidity in radial direction

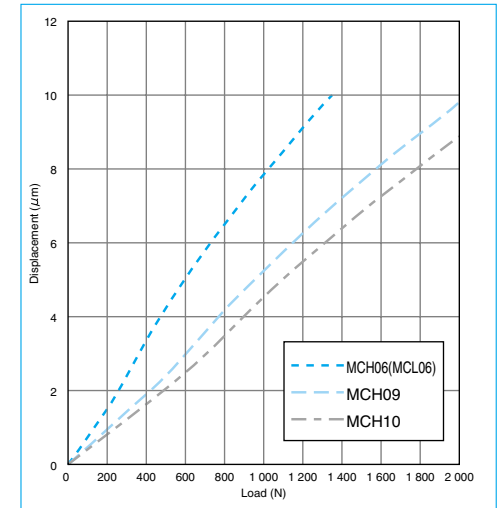

Fig. 1-7 MCH Series Rigidity in radial direction