

B-3-1.8 ND Series for Nut-Rotatable Drive

• This product is patented by NSK.

A nut rotatable ball screw is developed as a unit into which angular contact support ball bearings are integrated. It is best suited for an application that requires rotation of the ball nut while the screw shaft is fixed.

NDT model

1. Structure

Balls are installed between the assembly housing and the ball nut. The outer bearing rings are integrated into the assembly housing and thus, compact design are attained.

A timing pulley (prepared by the user) is directly secured to the end face of the nut.

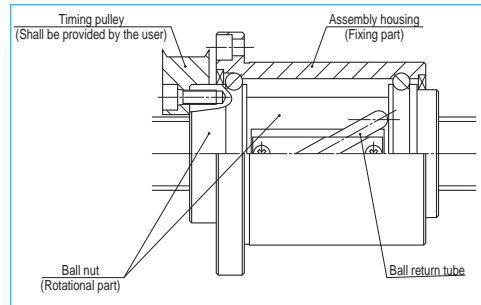

Fig. 1 Ball nut structure

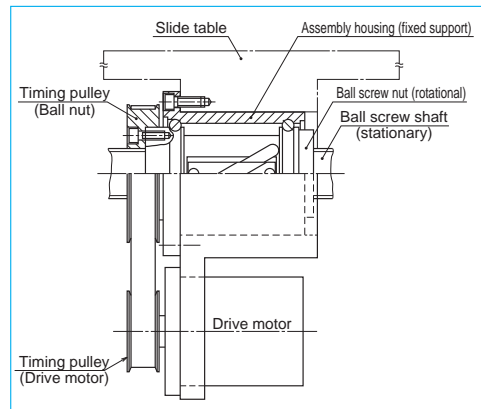

Fig. 2 Example of installation to the table

2. Features

● Multi-nut drive

Two or more nut units can be installed in a single ball screw shaft. They can be operated by respective motors.

● High operation speed

High feeding speed operation, but yet low rotational speed, is feasible by means of medium to high-helix lead ball screws.

● Easy installation

Merely install a mount housing to the table of the machine to take advantage of this multi-nut rotation system.

● Simple shaft end configuration

Shaft end configuration is simple because this unit does not need support bearings.

● Shaft diameter/lead combination

There are 10 types of "shaft diameter/lead" combinations.

Selections are: Shaft diameters -- 32, 40, 50 mm; Leads -- 20, 25, 32, 40, 50 mm.

● Low inertia

Compared to the NSK current product (end cap ball recirculation system), rotational inertia was reduced by 16% at most.

3. Specifications

(1) Recirculation system

The structure of return tube recirculation system is shown below.

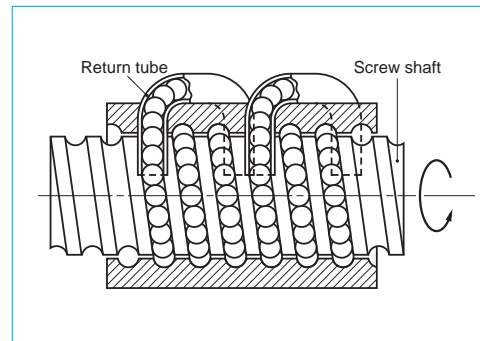

Fig. 3 Structure of ball return tube recirculation system

(2) Accuracy grade and axial play

The available standard accuracy grade and axial play are as follows. Please consult NSK for other grades.

Table 1 Axial play

Axial play code	Z	T	S
Axial play	0	0.005 mm or less	0.020 mm or less

Table 2 Combination of accuracy grades and axial play

Accuracy grade	C3	C5	Ct7
Axial play code	Z, T, S	Z, T, S	S

4. Allowable d·n value and the criterion of maximum rotational speed

Allowable d·n value and the criterion of maximum rotational speed are shown below. Please consult NSK if the rotational speed exceeds the permissible range below.

Note: The basic concept is the same as that of general ball screws. Refer to "Technical Description: Permissible rotational speed" (Page B51).

Table 3 Allowable d·n value and the criterion of maximum rotational speed

Allowable d·n value	Standard specification	70000 or less
	High-speed specification	100000 or less
Criterion of maximum rotational speed	3000 min ⁻¹	

d·n value: shaft dia. d [mm] × Rotational speed n [min⁻¹]

● Critical speed n_c

As shown Fig. 4, calculate unsupported length (mm) of L₁, L₂, and L₃ (Assumed that the nut section is a fixed support.) Table 4 shows the coefficients "f" of each shaft end mounting condition.

$$n_c = f \cdot \frac{d}{L_i^2} \times 10^7 \text{ (min}^{-1}\text{)} \quad \text{(III-1)}$$

d: Screw shaft root diameter [See the dimension table]

L_i: Unsupported length (mm) [See Fig. 4 Unsupported length]

f: Factor determined by the ball screw shaft end mounting condition

Table 4

Shaft end mounting condition	f
Fixed -- Fixed support	21.9
Fixed -- Simple support	15.1
Fixed -- Free support	3.4

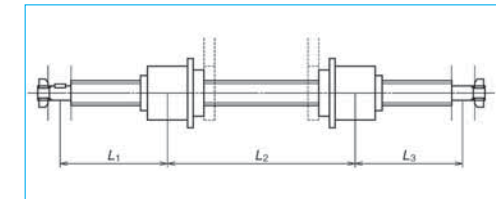

Fig. 4 Installation example

5. Design precautions

One end of the screw thread should be cut-through. Also, if the nut must be removed from the screw shaft, the user should have an arbor to prevent the balls from falling out during this process. (NSK manufactures arbors on request.) For general precautions regarding ball screws, refer to "Design Precautions" (Page B84) and "Handling Precautions" (Page B103).

NDD Type: (Incorporating vibration damper)

An increase in stroke length may restrict required rotational speed of a ball screw due to the issue of critical speed even if there is no problem on d·n limitation.

In such a case, we recommend using NDD Type nut rotatable ball screws equipped with vibration damper.

It will make it possible to operate a ball screw exceeding the critical speed, which is conventionally considered being impossible.

Note: 1) However, NDD Type cannot be used exceeding the d·n limitation. Please consult with NSK in such a case.

2) You cannot rotate the screw shaft of NDD Series.

1. Structure

Hollow ball screw shaft has a mechanism to absorb vibration energy (vibration damper). This increases dynamic rigidity of the screw shaft and lowers vibration when exceeding the critical speed.

Construction of the ball nuts are the same as those of NDT Type.

2. Features

- No need for measures against critical speed. Conventionally, an increase in screw shaft diameter or use of intermediate support is the measure against the issue of critical speed. NDD Type ball screw will make these measures needless.

- Dimensional interchangeability with NDT Type ball screws

The vibration damper is set inside a ball screw shaft, and therefore, there is no difference with existing series in regards to external dimensions. The ball nuts of NDD Type are interchangeable with those of NDT Type.

- Others

Benefits in multiple ball nut on a screw shaft, high feeding speed for long stroke, easy in installation, and low inertia of the ball nuts are the same as NDT Type.

3. Specification

Recirculation system, accuracy grade, axial play and preload system are the same as NDT Type.

4. Design precautions

They are the same as NDT Type.

5. Permissible rotational speed

The d·n value is the same as NDT Type. You don't need to consider the critical speed.

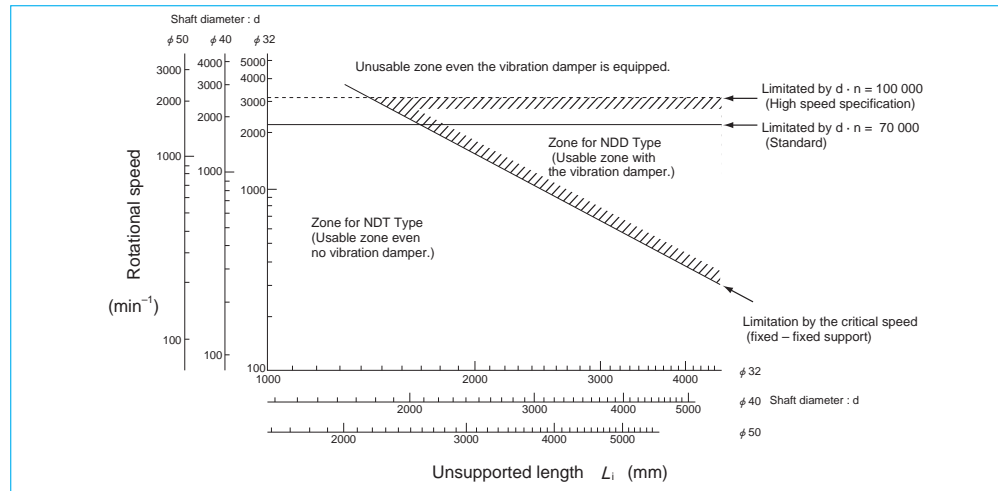

Fig. 5 Type composition to rotational speed and unsupported length

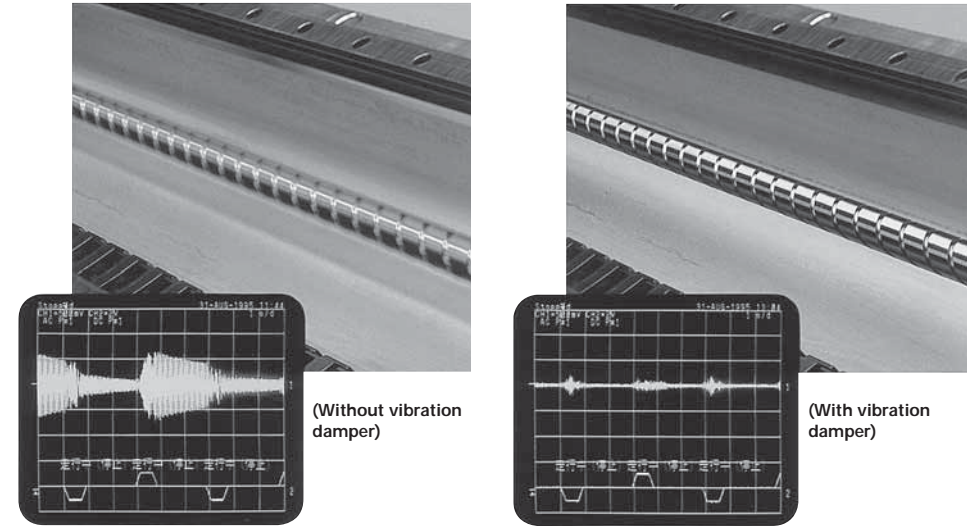

Fig. 6 Vibration of screw shaft when nut is rotating

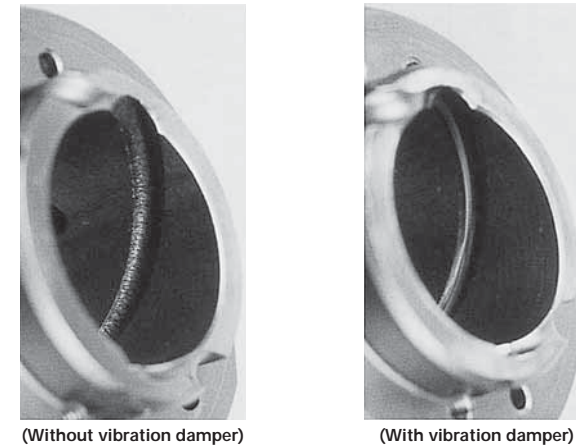

Fig. 7 Effect of vibration damper (results of endurance test)

Calculation example of permissible rotational speed

[Calculation example]

Assume a system which moves two nuts on a shaft as shown at below.

Does this system operate appropriately if: both ends of the ball screw (shaft diameter 40 mm/lead 40 mm) are fixed, and the travel speed is at 60 m/min?

[Answer]

The rotational speed n (min^{-1}) when the lead of the ball screw is 40 mm, and the travel speed is at 60 m/min is:

$$n = \frac{60 \times 10^3}{40} = 1500 \text{ (min}^{-1}\text{)}$$

● Calculate $d \cdot n$ value

As the $d \cdot n$ value of standard specification is 7000, therefore, the permissible rotational speed is;

$$n \leq \frac{70000}{40} = 1750 \text{ (min}^{-1}\text{)}$$

● Calculate critical speed

The maximum unsupported length comes between Nut A and B.

$$L_2 = 3300 \text{ (mm)}$$

$$f = 21.9 \text{ (Fixed-Fixed)}$$

$$\text{Root diameter: } d_r = 35.1 \text{ (mm)}$$

Therefore, the permissible rotational speed is;

$$n \leq \frac{21.9 \times 35.1}{3300^2} \times 10^7 = 706 \text{ (min}^{-1}\text{)}$$

The calculation indicates that the $d \cdot n$ value is at the safe level. But the critical speed exceeds the limitation. However, with a vibration damper, the system can be operated at 1500 min^{-1} .

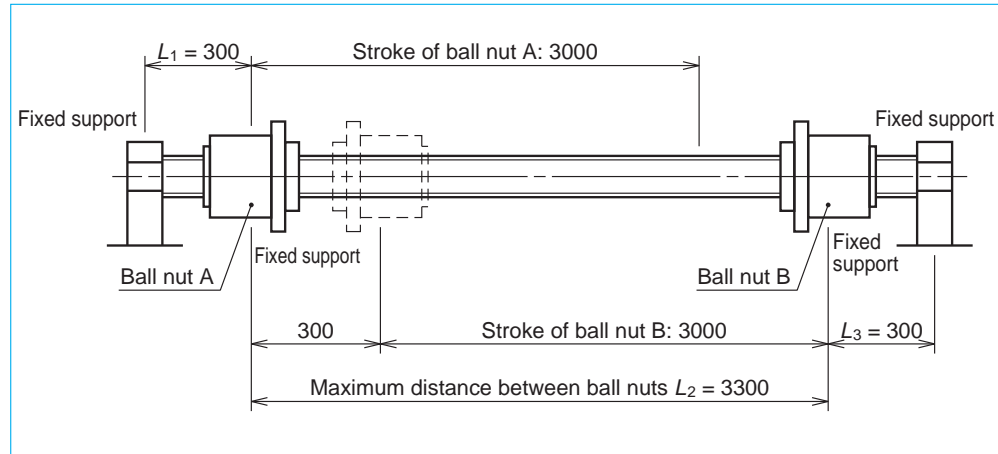

Fig. 8 Calculation example of permissible rotational speed

Example of model number in dimension table

A structure of "Reference number for ball screw" is as follows.

◇Reference number for ball screw

W 40 15 - ** P XU - C5 Z 40	
Product code	Lead (mm)
Screw shaft diameter (mm)	Axial play code: Z, T, S
Effective threaded length (in the unit of 100 mm)	Accuracy grade: C3, C5, C7 (Ct7)
Design serial number	Appearance/specification code ("T" is added for NDD Type)
Preload code: No code, Non-preload; P, P preload	

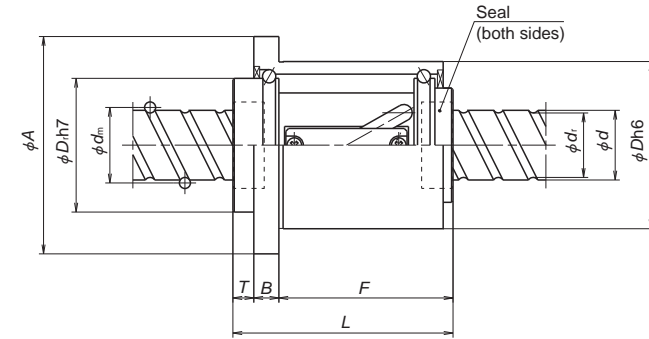
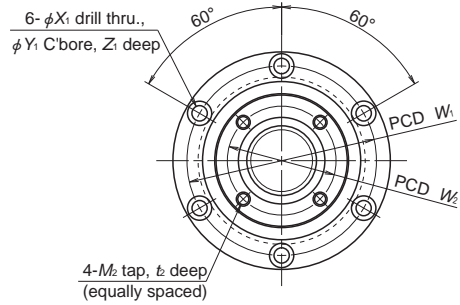

Unit: mm

Model No.	Shaft dia. <i>d</i>	Lead <i>l</i>	Ball dia. <i>D_w</i>	Ball circle dia. <i>d_m</i>	Root dia. <i>d</i>	Effective turns of balls Turns × Circuits	Basic load rating (N)		Moment of inertia, ball nut <i>J</i> (kg·cm ²)	Ball nut mass <i>W</i> (kg)
							Dynamic <i>C_a</i>	Static <i>C_{0a}</i>		
NDT NDD 3220-2.5	32	20	4.762	33.25	28.3	2.5×1	17900	41800	6.2	2.9
NDT NDD 3225-2.5		25	4.762	33.25	28.3	2.5×1	17900	41800	6.7	3.2
NDT NDD 3232-1.5		32	4.762	33.25	28.3	1.5×1	11500	24800	6.2	2.9
NDT NDD 3232-3						1.5×2	18900	44600		
NDT NDD 4025-2.5		40	25	6.35	41.75	35.1	2.5×1	28500	70000	19.3
NDT NDD 4032-1.5	32		6.35	41.75	35.1	1.5×1	18400	41200	18.0	5.5
NDT NDD 4032-3						1.5×2	30100	74100		
NDT NDD 4040-1.5	40		6.35	41.75	35.1	1.5×1	18400	41200	19.2	6.0
NDT NDD 4040-3						1.5×2	30100	74100		
NDT NDD 5025-2.5	50	25	7.938	52.25	44.0	2.5×1	42700	109000	45.7	8.5
NDT NDD 5032-2.5		32	7.938	52.25	40.0	2.5×1	42700	109000	48.9	9.4
NDT NDD 5040-1.5		40	7.938	52.25	44.0	1.5×1	27500	66500	45.5	8.5
NDT NDD 5040-3						1.5×2	44900	120000		
NDT NDD 5050-1.5		50	7.938	52.25	44.0	1.5×1	27500	66500	48.7	9.4
NDT NDD 5050-3	1.5×2					44900	120000			

Remarks 1. The right hand screw is the standard. Consult NSK for the left hand screws.
2. Seal is standard.

Ball nut dimensions													Tap hole PCD <i>W₂</i>
Nut entire length <i>L</i>	Nut outside diameter <i>D</i>	Flange outside diameter <i>A</i>	Flange width <i>B</i>	Nut length <i>F</i>	Projection tube dimensions <i>D_t</i> , <i>T</i>		Bolt hole dimensions <i>X₁</i> , <i>Y₁</i> , <i>Z₁</i>			Bolt hole PCD <i>W₁</i>	Tap hole dimensions <i>M₂</i> , <i>t₂</i>		
107	78	105	12	83	60	12	6.6	11	6.5	91	M6	12	50
120	78	105	12	96	60	12	6.6	11	6.5	91	M6	12	50
107	78	105	12	83	60	12	6.6	11	6.5	91	M6	12	50
136	100	133	15	106	76	15	9	14	8.5	116	M8	16	62
122	100	133	15	92	76	15	9	14	8.5	116	M8	16	62
136	100	133	15	106	76	15	9	14	8.5	116	M8	16	62
140	120	156	18	107	96	15	11	17.5	11	136	M10	18	78
158	120	156	18	125	96	15	11	17.5	11	136	M10	18	78
140	120	156	18	107	96	15	11	17.5	11	136	M10	18	78
158	120	156	18	125	96	15	11	17.5	11	136	M10	18	78