

# A-6 Other Linear Rolling Guide Products

## A-6-1 Linear Rolling Bushing

### (1) Features

#### 1. Low friction

Low friction owes to its design: Balls come into point contacts with raceway surface: the balls smoothly re-circulate. There is very little stick slip.

#### 2. Low noise

Noise level is low due to the ball retainer which is made of a synthetic resin.

#### 3. High precision

Due to NSK's superb quality control, precision is guaranteed.

#### 4. Dust prevention

Series with seal is available. The seal has small friction, and is highly durable. Highly dust-preventive double-lip system has been adopted.

#### 5. Superb durability

The material of outer sleeve is vacuum degassed, highly pure, and is heat-treated with good expertise.

#### 2. Adjustable clearance type LB-T (Fig. 2)

A part of the outer sleeve is cut open toward the axial direction. Used with a housing which can adjust inside diameter, it makes minute adjustment of the clearance between the linear shaft and the inscribed circle (an imaginary circle that connects the summit of the ball) of linear rolling bushing.



Fig. 2 Adjustable Clearance type LB-T

#### 3. Open type LB-K (Fig. 3)

A cut is made in the outer sleeve and retainer, to a width equivalent to one row of the retainer, to the axial direction. The opening is used to hold this linear rolling bushing by a support or base to prevent a long linear shaft from bending.



Fig. 3 Open type LB-K

### (2) Models

There are three models

#### 1. Standard type LB (Fig. 1)

This model is the most commonly used, and is the only model that comes with a seal and in super precision grade.



Fig. 1 Standard type LB

### (3) Accuracy

#### 1. Accuracy grades

- Standard type LB.....High precision grade S, and super precision grade SP are available.
- Space adjustment type LB-T.....
- Open type LB-K..... } High precision grade S is available.

#### 2. Tolerance of rolling linear bushing, linear shaft and housing

Table 1 Tolerance for inscribed circle of the linear rolling bushing and shaft diameter

Unit:  $\mu\text{m}$

Nominal dimension/ inscribed circle diameter /shaft diameter (mm)		Tolerance/inscribed circle diameter <sup>(1)</sup>				Tolerance/width B		Tolerance/slot distance of retaining rings Bn		Recommended tolerance/ shaft diameter			
		High precision grade S		Super high precision grade SP		High precision grade S Super high precision grade SP	High precision grade S Super high precision grade SP	High precision grade S Super high precision grade SP	High precision grade S Super high precision grade SP	High precision grade S Super high precision grade SP	High precision grade S Super high precision grade SP		
over	or less	upper	lower	upper	lower	upper	lower	upper	lower	upper	lower	upper	lower
2.5	6									-6	-14	-4	-9
6	10	0	-8	0	-5					-6	-15	-4	-10
10	18					0	-120	+240	-240	-6	-17	-4	-12
18	30	0	-10	0	-6					-6	-19	-4	-13
30	50	0	-12	0	-8					-7	-23	-5	-16

Table 2 Tolerance of linear rolling bush outside diameter, and housing inside diameter

Unit:  $\mu\text{m}$

Nominal dimension/ outside diameter/housing inside diameter (mm)		Tolerance/outside diameter D <sup>(1)</sup>				ccentricity <sup>(2)</sup>	Tolerance/housing inside diameter			
		High precision grade S		Super high precision grade SP		Super high precision grade SP	High precision grade S	Super high precision grade SP	High precision grade S	Super high precision grade SP
over	or less	upper	lower	upper	lower	Maximum	upper	lower	upper	lower
2.5	6						+12	0	+8	0
6	10	0	-10	0	-7	8	+15	0	+9	0
10	18						+18	0	+11	0
18	30	0	-12	0	-8	9	+21	0	+13	0
30	50	0	-14	0	-9	10	+25	0	+16	0

Note: 1) For adjustable clearance type and open type, figures indicate tolerances before the cut is made.

2) Eccentricity means the run-out of offset between the centers of outer sleeve diameter and inscribed circle diameter.

### (4) Composition of Reference Number

Example **LB 35 N K Y S**

Linear rolling bushing	<b>L</b>	<b>B</b>						No code..... No seal
Nominal inscribed circle diameter (linear shaft nominal diameter)			<b>35</b>					D..... Single-side seal
N..... With retaining ring groove				<b>N</b>				DD..... Double-side seal
No code..... Without retaining ring groove					<b>K</b>			Accuracy grade
No code..... Standard type LB						<b>Y</b>		S..... High precision grade
T..... Adjustable clearance type LB-T							<b>S</b>	SP..... Super precision grade
K..... Open type LB-K								Plastic retainer

(5) Lubrication and Friction

1. Grease lubrication

① Supply at initial stage

At time of delivery, the linear rolling bushing has a coat of rust preventive agent. Wipe it off with clean kerosene or organic solvent. Dry with an air blower, etc., then apply grease. Lithium soap based greases with consistency level of 2 are generally used (e.g. NSK Grease LR3, PS2, and AS2).

② Replenishment

- Sealed linear rolling bushing is designed to be a disposal item. Therefore, a replenishing grease is considered to be not required. However, if replenishment becomes necessary due to dirty environment or wear of the seal, remove the linear bushing from the shaft and replenish lubricant in the same manner as the initial lubricating.
- For items without seal, wipe off old grease from the linear shaft, and apply new grease.
- Intervals of replenishments are every 100 km in a dirty environment, 500 km in a slightly dirty environment, 1000 km or no replenishing for a normal environment.

2. Oil lubrication

It is not necessary to wash off the rust preventive agent applied before delivery. Use an oil of ISO viscosity grade VG15-100. Drip the oil on the linear shaft by an oil supply system.

Temperature to use

- 30°C to 50°C Viscosity VG15 - 46
- 50°C to 80°C Viscosity VG46 - 100

Lubricant is removed by the seal if the linear ball bearing has a seal. Therefore, the drip method cannot be used except for single-seal types.

3. Friction coefficient

The linear rolling bushing has a small dynamic friction coefficient. This contributes to low power loss and temperature rise.

Fig. 4 indicates dynamic friction coefficient is merely 0.001-0.004. Also, at the speed of under 60 m/min, there is no danger of the temperature rising.

Friction force can be obtained by the following formula.

$$F = \mu \cdot P \dots\dots\dots (1)$$

In this formula:

- F : Friction force (N)
- P : Load (vertical load to the shaft center line) (N)
- $\mu$  : Friction coefficient (dynamic or static)

For a seal type, a seal resistance of 0.3 to 2.40 N is added to the above.

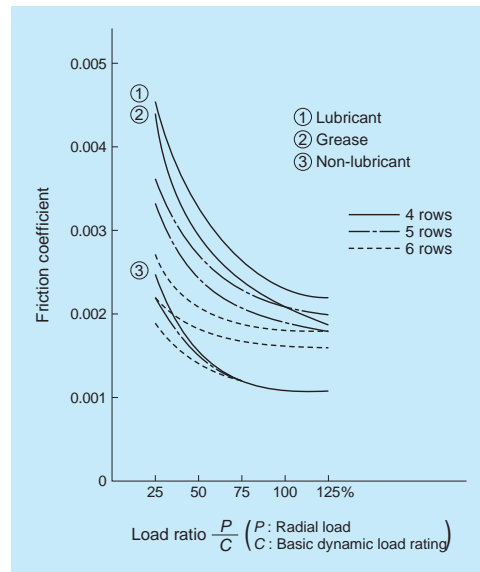

Fig. 4 Dynamic friction coefficient of linear rolling bushing

(6) Range of Conditions to Use

Generally, use under the following conditions.

Please consult NSK when values exceed the ranges given below.

Temperature.....Minus 30°C to plus 80°C

Speed.....Up to 120 m/min

(excluding oscillation and short strokes)

(7) Preload and Rigidity

The linear rolling bushing is normally used without applying preload. If high positioning accuracy is required, set the clearance between the linear rolling bush and the shaft at the range of 0 to 5  $\mu$ m. Slight preload is a general rule (1% of basic dynamic load rating C -- see the dimension table).

The dimension table shows theoretical rigidity  $K$  when clearance with the shaft is zero, and a load of 0.1 C is applied to the summit of the ball.

Rigidity  $K_n$ , when load is not 0.1 C, is obtained by the following formula.

$$K_n = K (P/0.1C)^{1/3} \dots\dots\dots (2)$$

In this formula:

- K : Rigidity value in the dimension table (N/ $\mu$ m)
- P : Radial load (N)

When the load is applied between the ball rows, the load becomes 1.122 times for 4 ball rows; 0.959 times for 5 ball rows; 0.98 times for 6 ball rows.

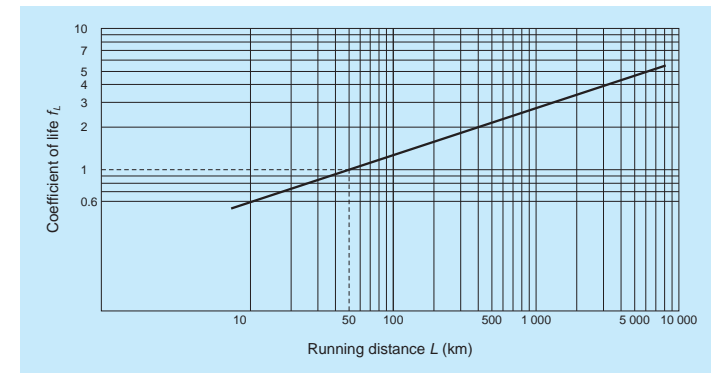

Fig. 5 Relationship between life factor and running distance

(8) Basic Load Rating and Rated Life

1. Basic dynamic load rating

Basic dynamic load rating C is: A radial load which allows 90% of a group of linear rolling bush to run a distance of 50 km without suffering damage when they are moved individually.

There is a relationship as below between C and the life

$$L = 50 f_L^3 \dots\dots\dots (3)$$

$$f_L = C/P \dots\dots\dots (4)$$

In this formula:

- L : Rated life (km)
- P : Radial load (N)
- $f_L$  : Life factor (Refer to Fig. 5)

This formula is used provided that the shaft hardness is HRC58 or higher. Rated life is shorter if the shaft is softer. In this case, find the hardness factor  $f_H$  from Fig. 6, and multiply the value.

$$f_L = C \cdot f_H/P \dots\dots\dots (5)$$

Or

$$C = P \cdot f_L/f_H \dots\dots\dots (6)$$

Life in time can be obtained by the following formula, substituting for given stroke length, cycle numbers, and running distance:

$$L_h = (L/1.2 \cdot S \cdot n) \times 10^4 \dots\dots\dots (7)$$

In this formula:

- $L_h$  : Life hours (h)
- L : Rated life (km)
- S : Stroke (mm)
- n : Cycles per minute (cpm)

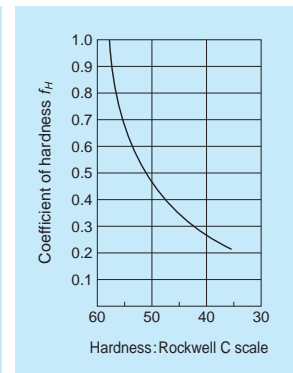

Fig. 6 Hardness factor

## 2. Basic static load rating

It is a load that the total permanent deformation of outer sleeve, ball and shaft, at the contact point, becomes 0.01% of the ball diameter when this load is applied to the rolling bushing. It is understood in general that this is the applicable load limit which causes this much permanent deformation, without hampering operation.

## 3. Calculation example

What is the appropriate rolling bushing size if required life is 5000 hours?

Conditions are:

- Three linear rolling bushings are installed in two parallel shafts, and support a reciprocating table.
- Load 450 N is equally distributed to the three bushings.
- The table is required to reciprocate on the shafts at 200 times per minute, at a stroke of 70 mm.
- Hardness of the shaft: HRC 55

$$450/3 = 150 \text{ (N)}$$

- Load per linear rolling bushing is:

From Formula (7), the required life, when indicated in distance, is:

$$L = 5 \times 10^3 \times 1.2 \times 70 \times 200/10^4 = 8.4 \times 10^3 \text{ (km)}$$

From Fig. 5 and Fig. 6,

Life factor  $f_L = 5.6$

Hardness factor  $f_H = 0.65$

Therefore, from Formula (6),

$$C = P \times f_L / f_H \\ = 150 \times 5.6 / 0.65 = 1292 \text{ (N)}$$

Based on the above, select linear rolling bushing LB30NY with shaft diameter of 30 mm, basic dynamic load rating of 1400 N.

## 4. Compensating load rating by ball row position

Load rating of the linear rolling bushing changes by the position of the ball circuit rows.

Permissible load is larger when it is applied to the middle of the ball circuit rows than when it is applied directly above the ball row (Fig. 7).

(Radial clearance set at zero in this case.)

Load ratings in the dimension table are in case "A" when it is applied directly above the ball circuit row. If used as in case "B," the load rating becomes larger (Refer to Fig. 7).

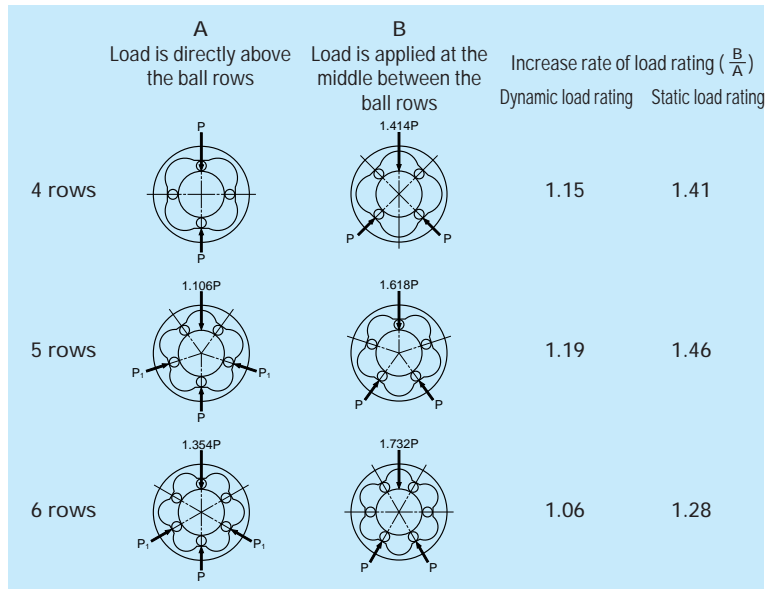

Fig. 7 Increasing rate of load rating by position of ball row (B/A)

## (9) Shaft Specification

Harden the shaft surface, where the balls run, with heat treatment to provide the following values.

- Surface hardness.....HRC58 or over
- Depth of core hardness at HRC50 or higher
  - Depth for LB3 ; 0.3 mm or deeper
  - Depth for LB50 ; 1.2 mm or deeper

Roughness of the surface should be:

- For SP grade, and "the clearance for fit" with the ball bushing less than  $5 \mu\text{m}$  - Less than 0.8 S
- For SP grade with "the clearance" of more than  $5 \mu\text{m}$ , and for S grade - Less than 1.2 S

Bending should be:

- LB3 --  $15 \mu\text{m}/100 \text{ mm}$
- LB50 --  $100 \mu\text{m}/1000 \text{ mm}$

An appropriate clearance for normal use conditions can be obtained when the tolerance in shaft diameter remains within the recommended range (refer to Table 1 in Page A366). For operations which require particular accuracy, select the shaft diameter which creates a clearance in the range of 0 to 0.005 (mm) for example, when assembled with the rolling bushing.

## (10) Dust Proof

Select a linear rolling bushing with seals to prevent moisture or foreign matters, which are floating in the air, from entering.

## (11) Installation

### 1. Combination of shaft and linear rolling bushing

When the linear rolling bushing is installed in a linear motion table for its reciprocating movement, it is necessary to prevent the table from rotating. In general, for this reason, two shafts, installed with two linear rolling bushings on each, are used. Fig. 8 is an installation example.

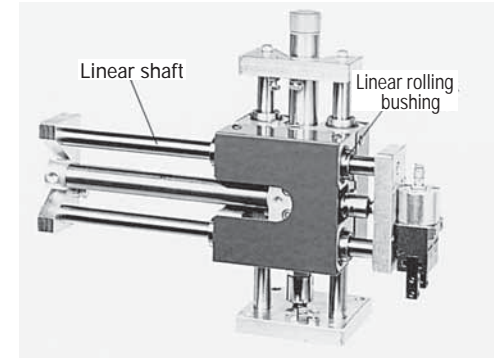

Fig. 8 Installation example

## 2. Installation of linear rolling bushing

### ① Standard type installation

Fig. 9 shows a method using a retaining ring. Linear rolling bushing can also be secured to the housing using a stop plate and/or screw.

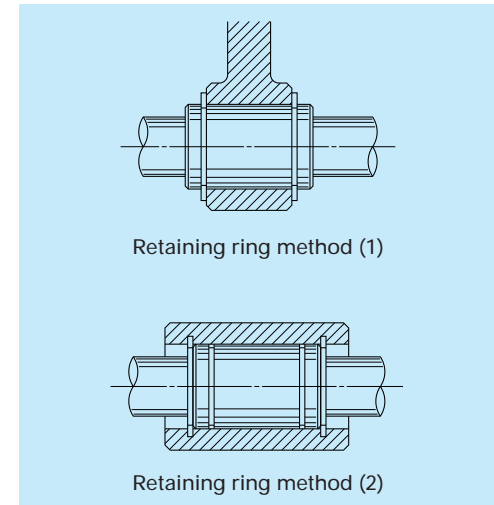

Fig. 9 Installation using retaining rings

- Ⓐ Housing inside diameter should be of a recommended value (Table 2, Page A366). The entire rolling bushing contracts and gives excessive preload if: the inside diameter is small ; the roundness or cylindricity is excessive. This may result in an unexpected failure.
- Ⓑ To install linear rolling bushing, use a tool (Fig. 10) and squeeze it in, or use a holder and lightly pound it.

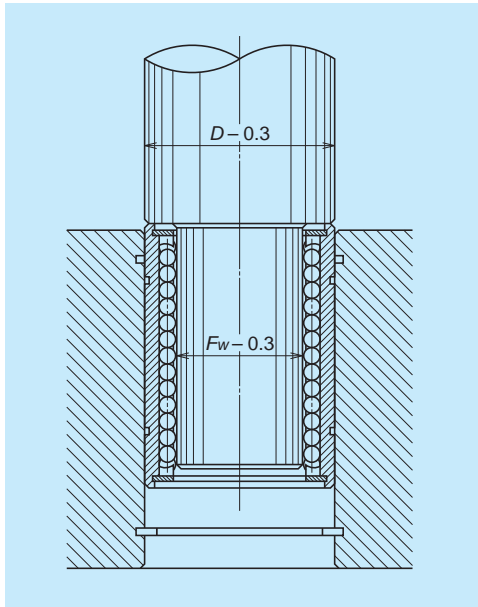

Fig. 10 Tool to install a linear rolling bushing

③ Installation of open type

Use with clearance or with light preload.  
 Keep the tolerance in shaft diameter within the recommended range (Refer to Table 1 in Page A366), so the preload shall not become excessive.  
 (Unlike the adjustable clearance type, clearance cannot be narrowed by rotating the shaft because the state of shaft rotation does not indicate how narrow the space has become. Narrowing clearance requires caution for open type.)

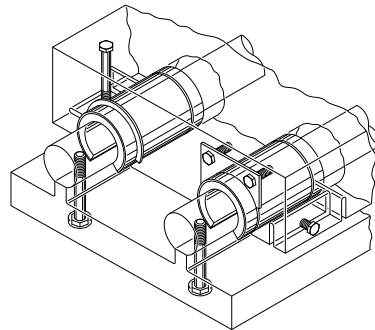

Fig. 11 Installation example of an open type

② Installation of adjustable clearance type

Use a housing which can adjust the inside diameter of the rolling bushing. This way, the clearance between the rolling bushing and the linear shaft can be easily adjusted. Arrange the cut-open section of the rolling bushing at a 90-degree angle to the housing's cut-open section. This is the most effective way to evenly distribute deformation toward circumferential direction.

The tolerance of shaft diameter of the adjustable clearance type should be within the recommended range (Refer to Table 1 in Page A366). As a general rule, set the preload at slight or light volume. (Do not provide excessive preload.) Use a dial gauge to measure and adjust clearance. However, here is an easy method to adjust.

First, loosen the housing until shaft turns freely. Then narrow the clearance gradually. Stop at the point when the shaft rotation becomes heavy. This creates a clearance zero or light preload.

3. Precaution for installing a shaft in the linear rolling bushing

- a) To install two shafts parallel to each other, first install one shaft accurately. Use this as a reference, and install the other parallel to the first shaft. This makes installation easy.
- b) Do not incline the shaft when inserting it into the linear rolling bushing. Do not force it to enter by twisting. This deforms the retainer, and causes the balls to fall out.
- c) Do not use the shaft for rotating movement after the shaft is in the linear rolling bushing. The balls slip and damage the shaft.
- d) Do not twist the shaft after it is in the linear rolling bushing. The pressure scars the shaft.

(12) Dimension tables

Model LB (standard type), no seal

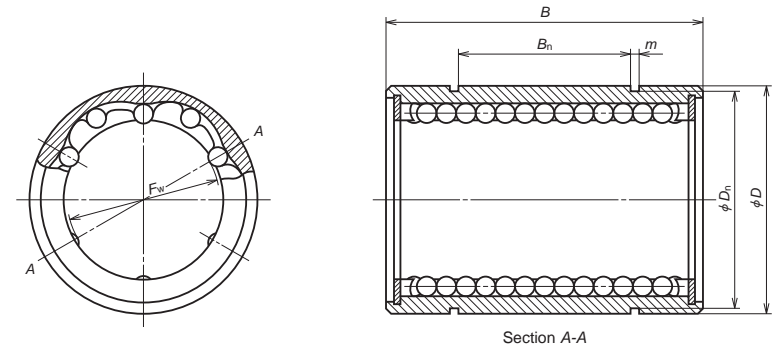

Unit: mm

Model No.	Inscribed circle diameter $F_w$	Outside diameter $D$	Length $B$	Retaining ring groove			Stiffness <sup>(1)</sup> (N/ $\mu$ m)	Number of ball circuit	Weight (kg) (Reference only)	Basic dynamic load rating $C$ (N)	Basic static load rating $C_0$ (N)
				Distance $B_n$	Width $m$	Bottom diameter $D_n$					
LB3Y	3	7	10	—	—	—	3	4	0.0016	20	39
LB4Y	4	8	12	—	—	—	4.5	4	0.0022	29	59
LB6NY	6	12	19	11	1.15	11.5	7	4	0.0074	74	147
<sup>(2)</sup> LB8ANY	8	15	17	9	1.15	14.3	5.5	4	0.0094	78	118
LB8NY	8	15	24	15	1.15	14.3	9.5	4	0.014	118	226
LB10NY	10	19	29	19	1.35	18	12	4	0.025	206	355
LB12NY	12	21	30	20	1.35	20	13	4	0.028	265	500
LB13NY	13	23	32	20	1.35	22	13	4	0.040	294	510
LB16NY	16	28	37	23	1.65	26.6	14	4	0.063	440	635
LB20NY	20	32	42	27	1.65	30.3	19	5	0.088	610	1010
LB25NY	25	40	59	37	1.9	38	35	6	0.267	1000	1960
LB30NY	30	45	64	40	1.9	42.5	41	6	0.305	1400	2500
LB35NY	35	52	70	45	2.2	49	48	6	0.440	1510	2800
LB40NY	40	60	80	56	2.2	57	54	6	0.520	2230	4000
LB50NY	50	80	100	68	2.7	76.5	69	6	1.770	4100	7100

Note (1): Refer to Section (7).

(2): Semi-standard item of which length B is shorter than standard.

Model LB (standard type), with seal

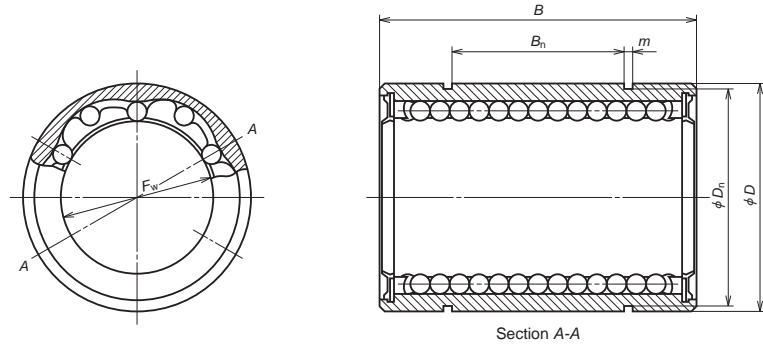

Model LB-T (Adjustable clearance type)

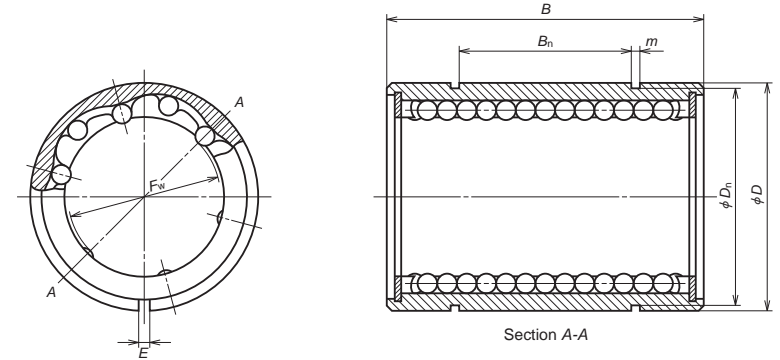

Unit: mm

Model No.	Inscribed circle diameter $F_w$	Outside diameter $D$	Length $B$	Retaining ring groove			Number of ball circuit	Weight (kg) (Reference only)	Basic dynamic load rating $C$ (N)	Basic static load rating $C_0$ (N)
				Distance $B_n$	Width $m$	Bottom diameter $D_n$				
LB6NYDD	6	12	19	11	1.15	11.5	4	0.0074	74	147
LB8ANYDD	8	15	17	9	1.15	14.3	4	0.0094	78	118
LB8NYDD	8	15	24	15	1.15	14.3	4	0.014	118	226
LB10NYDD	10	19	29	19	1.35	18	4	0.025	206	355
LB12NYDD	12	21	30	20	1.35	20	4	0.028	265	500
LB13NYDD	13	23	32	20	1.35	22	4	0.040	294	510
LB16NYDD	16	28	37	23	1.65	26.6	4	0.063	440	635
LB20NYDD	20	32	42	27	1.65	30.3	5	0.088	610	1010
LB25NYDD	25	40	59	37	1.9	38	6	0.267	1000	1960
LB30NYDD	30	45	64	40	1.9	42.5	6	0.305	1400	2500
LB35NYDD	35	52	70	45	2.2	49	6	0.440	1510	2800
LB40NYDD	40	60	80	56	2.2	57	6	0.520	2230	4000
LB50NYDD	50	80	100	68	2.7	76.5	6	1.770	4100	7100

Unit: mm

Model No.	Inscribed circle diameter $F_w$	Outside diameter $D$	Length $B$	Opening width $E$	Retaining ring groove			Number of ball circuit	Weight (kg) (Reference only)	Basic dynamic load rating $C$ (N)	Basic static load rating $C_0$ (N)
					Distance $B_n$	Width $m$	Bottom diameter $D_n$				
LB6NTY	6	12	19	0.8	11	1.15	11.5	4	0.0073	74	147
LB8ANTY	8	15	17	1	9	1.15	14.3	4	0.0093	78	118
LB8NTY	8	15	24	1	15	1.15	14.3	4	0.014	118	226
LB10NTY	10	19	29	1.5	19	1.35	18	4	0.025	206	355
LB12NTY	12	21	30	1.5	20	1.35	20	4	0.028	265	500
LB13NTY	13	23	32	1.5	20	1.35	22	4	0.040	294	510
LB16NTY	16	28	37	1.5	23	1.65	26.6	4	0.062	440	635
LB20NTY	20	32	42	2	27	1.65	30.3	5	0.087	610	1010
LB25NTY	25	40	59	2	37	1.9	38	6	0.265	1000	1960
LB30NTY	30	45	64	2	40	1.9	42.5	6	0.302	1400	2500
LB35NTY	35	52	70	3	45	2.2	49	6	0.44	1510	2800
LB40NTY	40	60	80	3	56	2.2	57	6	0.52	2230	4000
LB50NTY	50	80	100	3	68	2.7	76.5	6	1.75	4100	7100

Note (1) Single-seal type is indicated as LB-D.

Model LB-K (Open type)

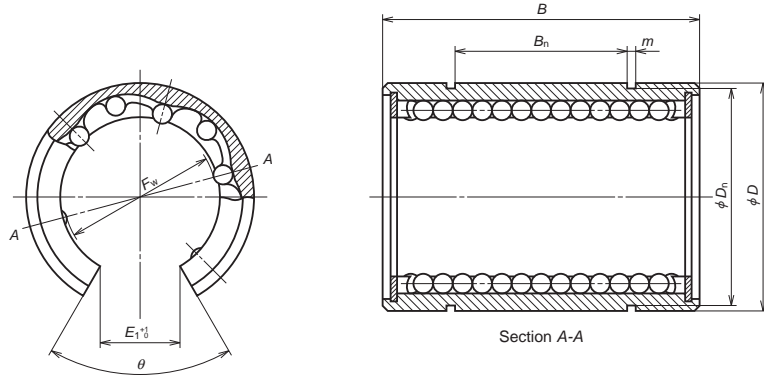

Unit: mm

Model No.	Inscribed circle diameter $F_w$	Outside diameter $D$	Length $B$	Opening width $E_1$	Opening angle $\theta$	Retaining ring groove			Number of ball circuit	Weight (kg) (Reference only)	Basic dynamic load rating $C$ (N)	Basic static load rating $C_0$ (N)
						Distance	Width	Bottom diameter $D_n$				
LB20NKY	20	32	42	11	60°	27	1.65	30.3	4	0.072	610	1010
LB25NKY	25	40	59	13	50°	37	1.9	38	5	0.220	1000	1960
LB30NKY	30	45	64	15	50°	40	1.9	42.5	5	0.260	1400	2500
LB35NKY	35	52	70	17	50°	45	2.2	49	5	0.370	1510	2800
LB40NKY	40	60	80	20	50°	56	2.2	57	5	0.440	2230	4000
LB50NKY	50	80	100	25	50°	68	2.7	76.5	5	1.480	4100	7100

A-6-2 Crossed Roller Guide

(1) Structure

Rollers with a retainer (hereinafter referred to as "retainer") are assembled in a pair of rails which have a V-shape groove. ( the grooves form a 90-degree angle. Refer to Fig. 1, 2). Rollers are placed crisscrossed, and are able to support load in all directions, including moment loads.

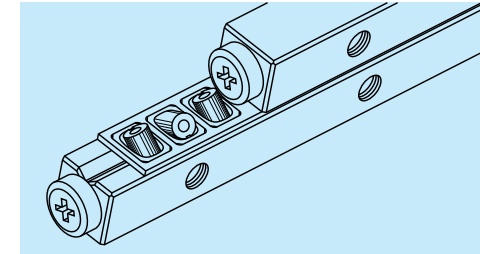

Fig. 1 Structure of crossed roller guide

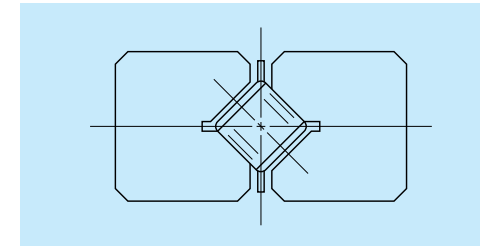

Fig. 2 Cross section of a crossed roller guide

(2) Features

- 1. High rigidity**  
This is attributable to the long contact area between the rollers and their accurately ground rolling surface.
- 2. Superbly smooth movement, low noise**  
The window which directly embraces the roller is made of plastic for smooth and quiet operation, lowering clatter when the retainer and the rollers come into contact.
- 3. Less micro-slip**  
Occasionally, a minute continuous slippage of the retainer to one direction, called "micro-slip," is caused due to installation error of the rail. After years of testing and research, NSK has developed technology to minimize this.
- 4. Easy installation**  
Installation is easy because the rail bending is

minimal, and the bolt hole pitch for installation is precise.

5. Long durability

The material is vacuum-degassed and highly pure, and is hardened by carburized heat treatment for superb resistance to wear and fatigue.

(3) Accuracy

Accuracy grade P5 super precision and high precision grade P6 are available.

Fig. 3 shows parallelism of the roller's rolling surface to the mounting datum face.

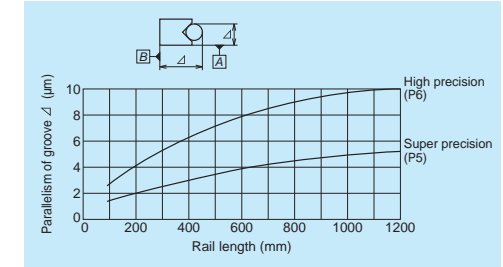

Fig. 3 Parallelism of the roller rolling surface

(4) Rigidity

The number of the load rollers changes by the direction of the load. This is because the rollers are positioned crisscross.

That is, in case of Fig. 4:

$$\text{The number of load rollers} = 1/2 \times \text{total roller number} \dots\dots\dots(1)$$

In case of Fig. 5:

$$\text{The number of load rollers} = \text{Total roller number} \dots\dots\dots(2)$$

Fig. 6 shows changes in elastic deformation when there are 20 load rollers. If the total number of rollers is other than 20, use the graph in Fig. 7. Obtain the compensation factor which converts the elastic deformation value at time of 20 load rollers into the value when a specific number of rollers are loaded. That is, obtain a compensation factor on the ordinate that correspond to the number of load rollers on the abscissa. Then, multiply this factor by the elastic deformation value (on ordinates) which corresponds to the load (on abscissa) shown in Fig. 6.