

A-5-1.6 LW Series

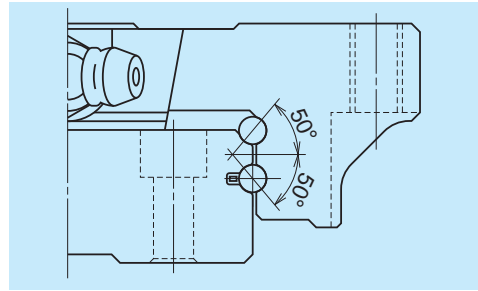
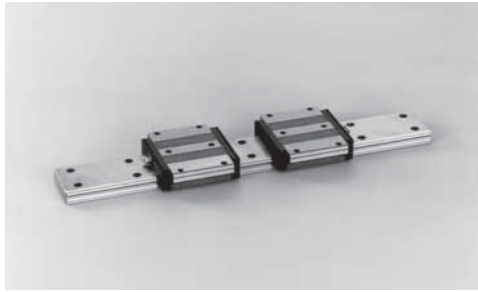

Fig. 1 Balls in contact

(1) Features

1. Ideal for use of single rail

Thanks to the wide rail, rigidity and load carrying capacity are high against moment load from rolling direction. This makes LW Series ideal in use of single rail as the linear guide.

2. High load carrying capacity to vertical direction

The contact angle is set at 50 degrees, increasing load carrying capacity as well as rigidity in vertical direction.

3. High resistance against impact load

Same as the LH and LS series, the offset Gothic arch grooves support a large load, such as an impact, by four rows.

4. High accuracy

Fixing master rollers is easy thanks to the Gothic arch groove. This makes easy and accurate measuring of ball grooves.

5. Easy to handle, and designed with safety in mind.

Balls are retained in the retainer and do not fall out when a ball slide is withdrawn from the rail.

6. Fast delivery

Lineup of random-matching rails and ball slides supports and facilitates fast delivery.

(2) Ball slide shape

Ball slide Model	Shape / installation method	Type
EL		

(3) Accuracy and preload

1. Running parallelism of ball slide

Table 1

Unit: μm

Rail over all length (mm) over or less	Preloaded assembly (not random matching)			Random-matching type
	High precision P5	Precision grade P6	Normal grade PN	Normal grade PC
- 50	2	4.5	6	6
50 - 80	3	5	6	6
80 - 125	3.5	5.5	6.5	6.5
125 - 200	4	6	7	7
200 - 250	5	7	8	8
250 - 315	5	8	9	9
315 - 400	6	9	11	11
400 - 500	6	10	12	12
500 - 630	7	12	14	14
630 - 800	8	14	16	16
800 - 1000	9	16	18	18
1000 - 1250	10	17	20	20
1250 - 1600	11	19	23	23
1600 - 2000	13	21	26	26
2000 - 2500	15	22	29	29
2500 - 3150	17	25	32	32
3150 - 4000	23	30	34	34

2. Accuracy standard

The preloaded assembly has three accuracy grades; High precision P5, Precision P6, and Normal PN grades, while the random-matching type has Normal PC grade.

• Tolerance of preloaded assembly type

Table 2

Unit: μm

Characteristics	High precision P5	Precision grade P6	Normal grade PN
Mounting height H Variation of H (All ball slides on a set of rails)	± 20 7	± 40 15	± 80 25
Mounting width W_2 or W_3 Variation of W_2 or W_3 (All ball slides on reference rail)	± 25 10	± 50 20	± 100 30
Running parallelism of face C to face A Running parallelism of face D to face B	Shown in Table 1 and Fig. 2		

• Tolerance of random-matching type: Normal grade PC

Table 3

Unit: μm

Characteristics	Model No.
	LW17, 21, 27, 35, 50
Mounting height H	± 20
Variation of mounting height H	15 ^① 30 ^②
Mounting width W_2 or W_3	± 30
Variation of mounting width W_2 or W_3	25
Running parallelism of face C to face A Running parallelism of face D to face B	See Table 1 and Fig. 2

Note: ① Variation on the same rail

② Variation on multiple rails

3. Combination of accuracy and preload

Table 4

	Accuracy grade				
	High precision	Precision grade	Normal grade	Random matching	
Without NSK K1 lubrication unit	P5	P6	PN	PC	
With NSK K1 lubrication unit	K5	K6	KN	KC	
With NSK K1 for food and medical equipment	F5	F6	FN	FC	
Preload	Fine clearance Z0	○	○	○	—
	Slight preload Z1	○	○	○	—
	Medium preload Z3	○	○	—	—
	Random-matching type with fine clearance ZT	—	—	—	○
	Random-matching type with slight preload ZZ	—	—	—	○

Note: Z3 medium preload are LW35 and 50 only

4. Assembled accuracy

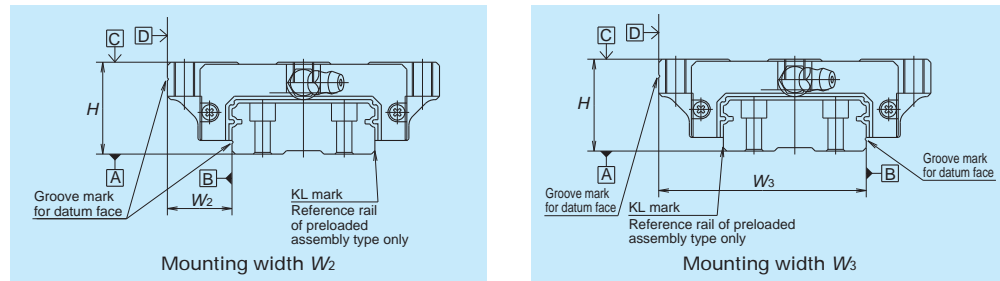

Fig. 2

5. Preload and rigidity

We offer five levels of preload: slight preload Z1, medium preload Z3 and fine clearance Z0, along with random-matching type of fine clearance ZT and slight preload ZZ. Values for preload and rigidity of the preloaded assembly are shown in Table 5. Rigidities are for the median of the preload range.

• Preload and rigidity of preloaded assembly

Table 5

Model No.	Preload (N)		Rigidity (N/μm)			
	Slight preload Z1	Medium preload Z3	Vertical directions		Lateral direction	
			Slight preload Z1	Medium preload Z3	Slight preload Z1	Medium preload Z3
LW17 EL	0 – 245	—	156	—	112	—
LW21 EL	0 – 294	—	181	—	130	—
LW27 EL	0 – 390	—	226	—	167	—
LW35 EL	0 – 490	785	295	440	213	315
LW50 EL	0 – 590	1470	345	600	246	425

Note: Clearance for fine clearance Z0 is 0 to 3μm. Therefore, preload is zero. However, Z0 of PN grade is 0 to 15μm.

• Clearance and preload of random-matching type

Table 6

Unit: μm

Model No.	Fine clearance ZT	Slight preload ZZ
	LW17	-3 – 15
LW21	-3 – 15	-3.5 – 0
LW27	-4 – 15	-4 – 0
LW35	-5 – 15	-5 – 0
LW50	-5 – 15	-7 – 0

Note: Minus sign denotes that a value is an amount of preload (elastic deformation of balls).

(5) Installation

1. Permissible values of mounting error

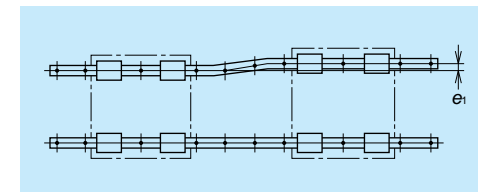

Fig. 3

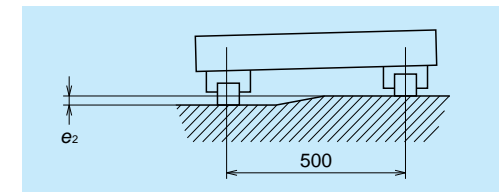

Fig. 4

Table 8

Unit: μm

Value	Preload	Model No.				
		LW17	LW21	LW27	LW35	LW50
Permissible values of parallelism in two rails e_1	Z0, ZT	20	20	25	38	50
	Z1	9	9	13	23	34
Permissible values of parallelism (height) in two rails e_2	Z0, ZT	100 μm/500 mm				
	Z1	45 μm/500 mm				

2. Shoulder height of the mounting face and corner radius r

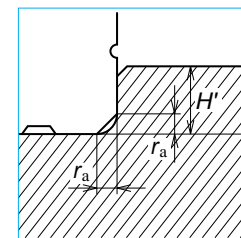

Fig. 5 Shoulder for the rail datum face

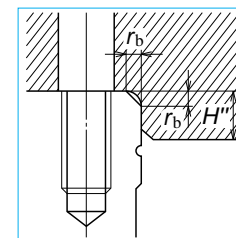

Fig. 6 Shoulder for the ball slide datum face

Table 9

Unit: mm

Model No.	Corner radius (maximum)		Shoulder height	
	r_a	r_b	H'	H''
LW17	0.3	0.3	2.2	4
LW21	0.3	0.3	2.5	5
LW27	0.5	0.5	3.5	5
LW35	0.5	0.8	3.5	5
LW50	0.8	0.8	4	6

(6) Lubrication components

Refer to page A38 and D13 for the lubrication of linear guides.

1. Types of lubrication accessories

Figure 11 and Table 10 show grease fittings and tube fittings.

We provide lubrication accessories with extended thread body length (L) for the addition of dust proof accessories such as NSK K1 lubrication unit, double seal and protector.

We provide a suitable lubrication accessory for the special requirement on dust proof accessories.

Consult NSK for a lubrication accessory with extended length of thread body for your convenience of replenishing lubricant.

Please ask NSK for stainless lubrication accessories.

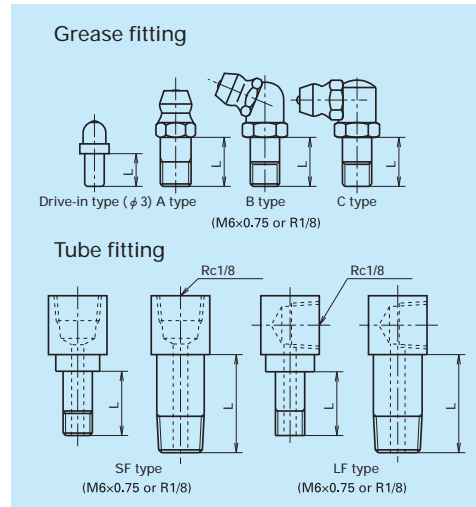

Fig. 7 Grease fitting and tube fitting

2. Mounting position of lubrication accessories

The standard position of grease fittings is the end face of ball slide. We mount them on a side of end cap for LW27, 35, and 50 as an option. (Fig. 8)

Please consult NSK for installation of grease or tube fittings to the ball slide body or side of end cap.

When using a piping unit with thread of M6 × 1, you require a connector to connect to a grease fitting mounting hole with M6 × 0.75. The connector is available from NSK.

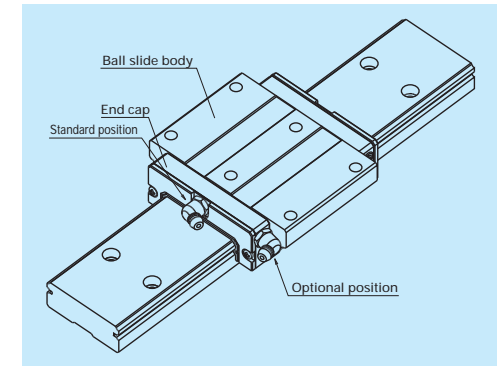

Fig. 8 Mounting position of lubrication accessories

Table 10 Unit: mm

Model No.	Dust proof specification	Grease fitting	Tube fitting
		Thread body length L	Thread body length L
LW17	Standard	5	-
	With NSK K1	10	-
	Double seal	*	-
	Protector	*	-
LW21	Standard	5	-
	With NSK K1	12	-
	Double seal	10	-
	Protector	10	-
LW27	Standard	5	-
	With NSK K1	12	-
	Double seal	10	-
	Protector	10	-
LW35	Standard	5	6
	With NSK K1	14	13
	Double seal	10	9
	Protector	10	9
LW50	Standard	8	17
	With NSK K1	18	19
	Double seal	14	17
	Protector	14	17

*) Please contact NSK as a connector is required.

(7) Dust proof components

1. Standard Specification

To keep foreign matters from entering inside the ball slide, LW Series has an end seal on both ends, and bottom seals at the bottom.

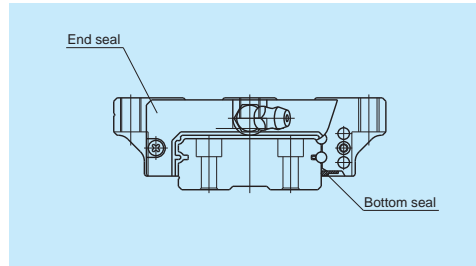

Fig. 9

Table 11 Seal friction per ball slide (maximum value) Unit : N

Series	Size	17	21	27	35	50
LW		6	8	12	16	20

2. NSK K1™

Table 12 shows the dimension of linear guides equipped with the NSK K1.

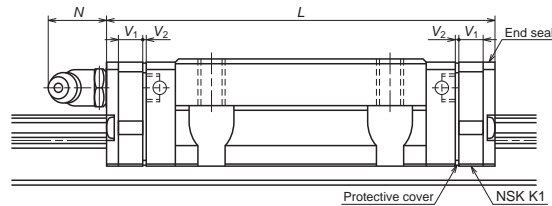

Table 12 (Unit : mm)

Model No.	Ball slide length	Ball slide model	Standard ball slide length	Ball slide length installed with two NSK K1 L	Per NSK K1 thickness V ₁	Protective cover thickness V ₂	Protruding area of the grease fitting N
LW17	Standard	EL	51.4	61.6	4.5	0.6	(5)
LW21	Standard	EL	58.8	71.4	5.5	0.8	(13)
LW27	Standard	EL	74	86.6	5.5	0.8	(13)
LW35	Standard	EL	108	123	6.5	1.0	(13)
LW50	Standard	EL	140.6	155.6	6.5	1.0	(14)

Note: NSK K1 for food and medical equipments are available for LW17 to LW35.

3. Double seal

Use a double seal set as showing in Table 13, when installing an extra seal to completed standard products. (Fig. 10)

When installing a grease fitting after the installation of double seals, a connector is required.

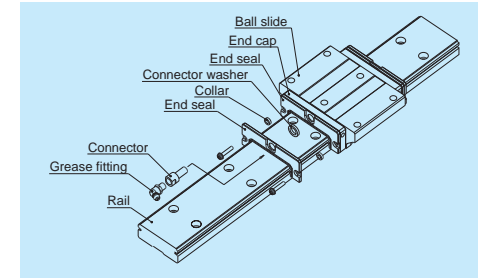

Fig. 10 Double seal

Table 13 Double-seal set

Model No.	Reference No.		Increased thickness V ₁
	Without connector	With connector	
LW17	LW17WS-01	*	2.6
LW21	LW21WS-01	LW21WSC-01	2.8
LW27	LW27WS-01	LW27WSC-01	2.5
LW35	LW35WS-01	LW35WSC-01	3
LW50	LW50WS-01	LW50WSC-01	3.6

*) For installation of a connector to a drive-in type grease fitting, contact NSK.

4. Protector

Use a protector set as showing Table 14, when installing a protector to completed standard products. (Fig.11)

When installing a grease fitting after the installation of protectors, a connector is required.

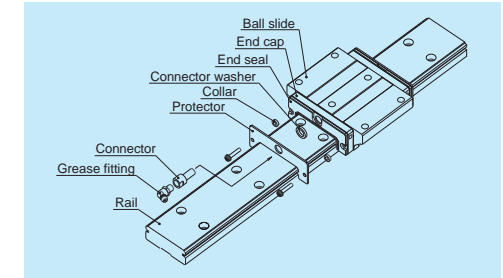

Fig. 11 Protector seal

Table 14 Protector set

Model No.	Reference No.		Increased thickness V ₂
	Without connector	With connector	
LW17	LW17PT-01	*	3.2
LW21	LW21PT-01	LW21PTC-01	3.2
LW27	LW27PT-01	LW27PTC-01	2.9
LW35	LW35PT-01	LW35PTC-01	3.6
LW50	LW50PT-01	LW50PTC-01	4.2

*) For installation of a connector to a drive-in type grease fitting, contact NSK.

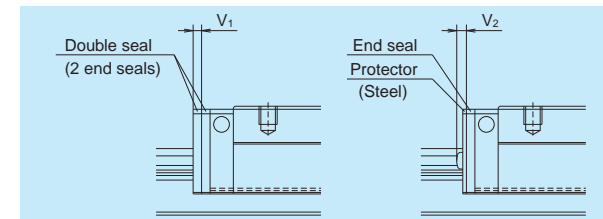

Fig. 12

5. Cap to cover the bolt hole for rail mounting

Table 15 Caps to cover rail bolt hole

Model No.	Bolt to secure rail	Cap reference No.	Quantity /case
LW17, LW21, LW27	M4	LG-CAP/M4	20
LW35	M6	LG-CAP/M6	20
LW50	M8	LG-CAP/M8	20

6. Bellows

- While removing machine screws which secure the end seal to install the bellows to the slide, for LW17 and 21, hold the end cap by hand not to be detached from the slide.
- Make tap holes to the rail end face to fix the bellows mounting plate. NSK processes tap holes to the rail end face when ordered with a linear guide.

Dimension tables of bellows
LW series

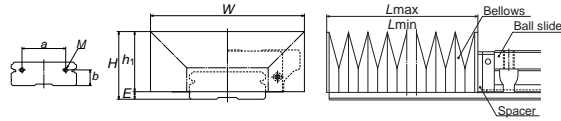

Fig. 13

Bellows reference number

J A W 21 L 08

Bellows

A: Bellows for the ends
B: Middle bellows

Bellows for LW series

Number of BL (fold number)

N : High type L : Low type

Size number of linear guide

Table 16 Dimensions of bellows

Unit: mm

Model No.	H	h ₁	E	W	P	a	b	BL minimum length	Tap (M) x depth
JAW17N	25.5	23	2.5	68	15	22	6	17	M3×6
JAW21N	29	26	3	75	17	26	7	17	M3×6
JAW27N	37	33	4	85	20	28	10	17	M3×6
JAW35L	34	30	4	100	14	48	12	17	M4×8
JAW35N	41	37		115	20				
JAW50L	46.5	42	4.5	135	20	70	14	17	M4×8
JAW50N	56.5	52		160	30				

Table 17 Numbers of folds (BL) and length of bellows

Unit: mm

Model No.	Number of BL	2	4	6	8	10	12	14	16	18	20
		L _{min}	34	68	102	136	170	204	238	272	306
JAW17N	Stroke	176	352	528	704	880	1056	1232	1408	1584	1760
	L _{max}	210	420	630	840	1050	1260	1470	1680	1890	2100
JAW21N	Stroke	204	408	612	816	1020	1224	1428	1632	1836	2040
	L _{max}	238	476	714	952	1190	1428	1666	1904	2142	2380
JAW27N	Stroke	246	492	738	984	1230	1476	1722	1968	2214	2460
	L _{max}	280	560	840	1120	1400	1680	1960	2240	2520	2800
JAW35L	Stroke	162	324	486	648	810	972	1134	1296	1458	1620
	L _{max}	196	392	588	784	980	1176	1372	1568	1764	1960
JAW35N	Stroke	218	436	654	872	1090	1308	1526	1744	1962	2180
	L _{max}	252	504	756	1008	1260	1512	1764	2016	2268	2520
JAW50L	Stroke	246	492	738	984	1230	1476	1722	1968	2214	2460
	L _{max}	280	560	840	1120	1400	1680	1960	2240	2520	2800
JAW50N	Stroke	386	772	1158	1544	1930	2316	2702	3088	3474	3860
	L _{max}	420	840	1260	1680	2100	2520	2940	3360	3780	4200

Remarks: Values of odd numbers BL (3, 5, 7, ...) can be obtained by adding two values of even number BLs on both sides, then dividing the sum by two.

(8) Reference number

Reference numbers shall be set to individual NSK linear guide when its specifications are finalized, and it is indicated on its specification drawing.

Please specify the reference number, except design serial number, to identify the product when ordering, requiring estimates, or inquiring about specifications from NSK.

1. Reference number for preloaded assembly

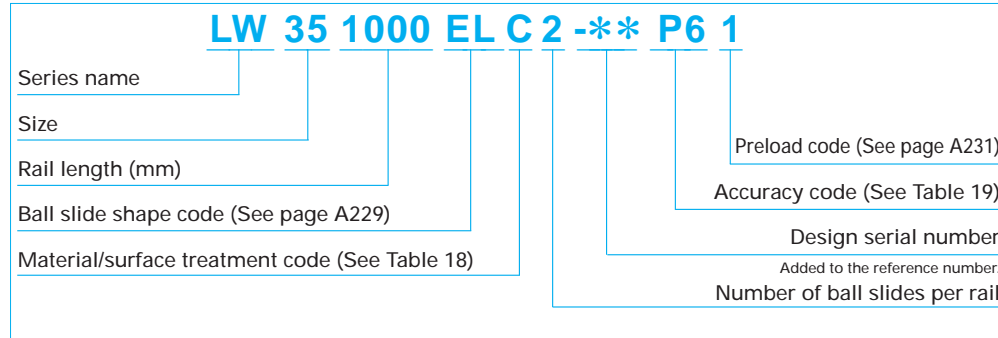

2. Reference number for random-matching type

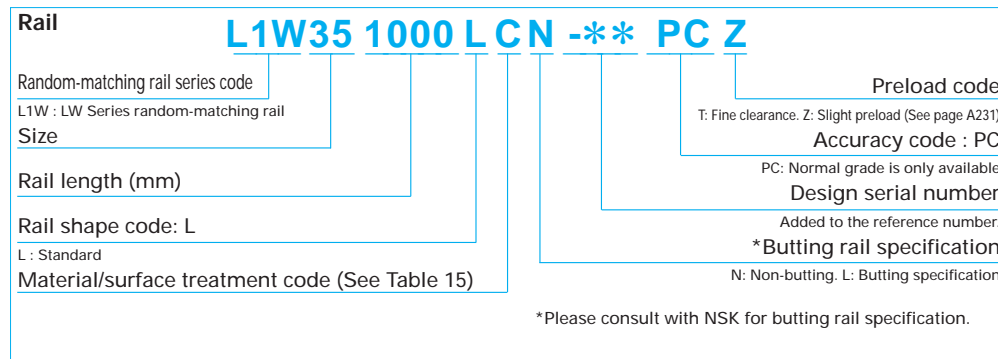
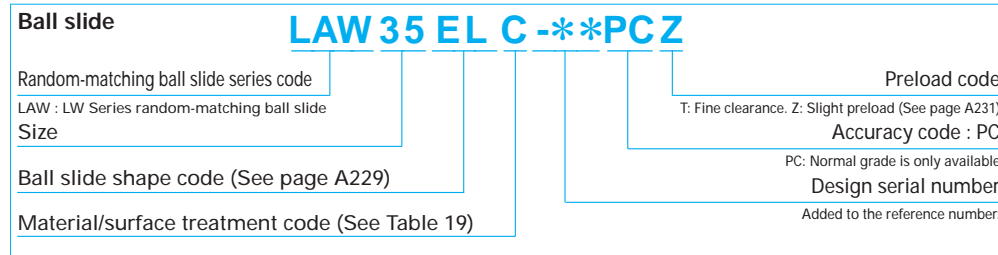

Reference number for assembly of random-matching ball slide and rail is the same as the coding of preloaded assembly. However, preload code is fine clearance "T" or slight preload "Z" (Refer to page A231).

Table 18 Material/surface treatment code

Code	Description
C	Special high carbon steel (NSK standard)
D	Special high carbon steel with surface treatment
Z	Other, special

Table 19 Accuracy code

Accuracy	Standard (Without NSK K1)	With NSK K1	With NSK K1 for food and medical equipment
High precision grade	P5	K5	F5
Precision grade	P6	K6	F6
Normal grade	PN	KN	FN
Normal grade (random-matching type)	PC	KC	FC

Note: Refer to Page A38 and A61 for NSK K1 lubrication unit.

(9) Dimensions

LW-EL

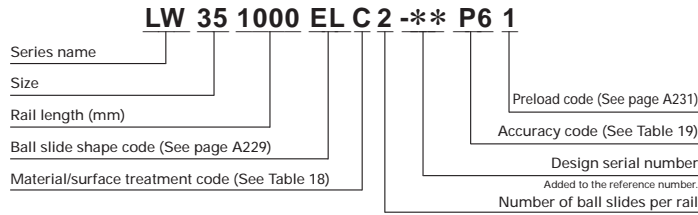

Front view of EL types

Side view of EL type

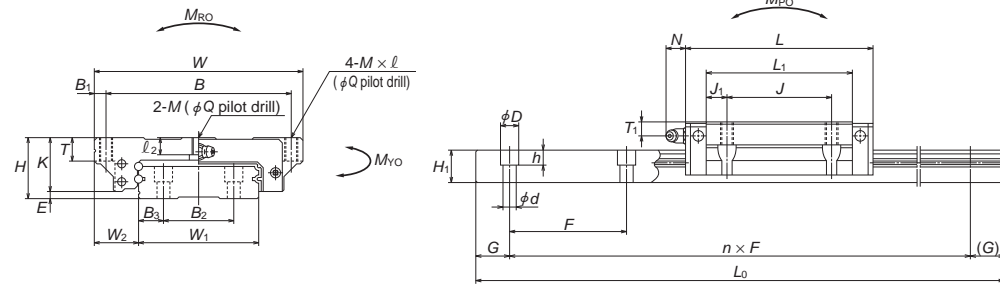

Reference number for ball slide of random-matching type

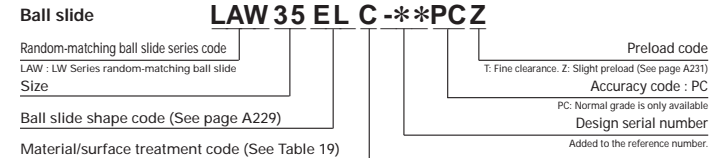

EL type

EL type

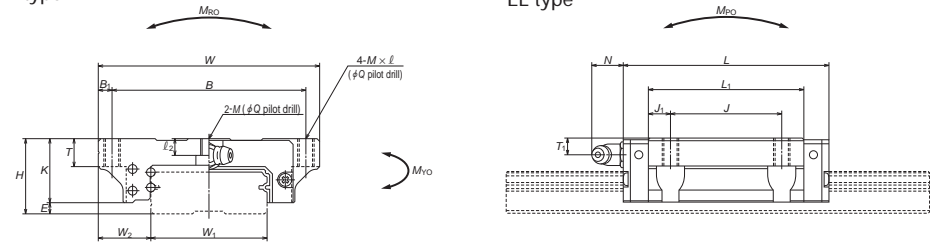

Reference number for rail of random-matching type

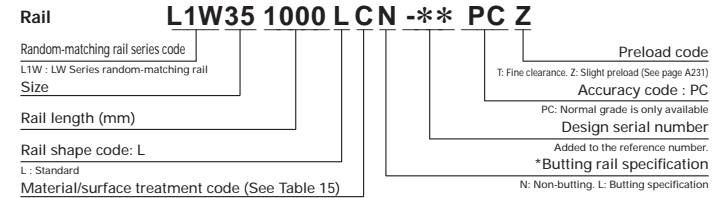

*Please consult with NSK for butting rail specification.

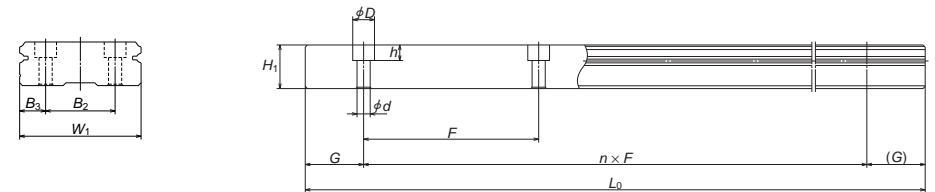

Model No.	Assembly			Ball slide															
	Height H	E	W ₂	Width W	Length L	Mounting hole								Grease fitting					
						B	J	M × pitch × l	l ₂	Q	B ₁	L ₁	J ₁	K	T	Hole size	T ₁	N	
LW17EL	17	2.5	13.5	60	51.4	53	26	M4×0.7×6	3.2	3.3	3.5	35	4.5	14.5	6	φ3	4	3	
LW21EL	21	3	15.5	68	58.8	60	29	M5×0.8×8	3.7	4.4	4	41	6	18	8	M6×0.75	4.5	11	
LW27EL	27	4	19	80	74	70	40	M6×1×10	6	5.3	5	56	8	23	10	M6×0.75	6	11	
LW35EL	35	4	25.5	120	108	107	60	M8×1.25×14	9	6.8	6.5	84	12	31	14	M6×0.75	8	11	
LW50EL	50	4.5	36	162	140.6	144	80	M10×1.5×18	14	8.6	9	108	14	45.5	18	Rc1/8	14	14	

Rail										Basic load rating					Ball dia.	Weight	
Width W ₁	Height H ₁	Pitch B ₂	Mounting bolt hole F	d × D × h	B ₃	G Reference	Maximum length L _{0max}	Dynamic C (N)	Static C ₀ (N)	Static moment			D _w	Ball slide (kg)	Rail (kg/m)		
										M _{RO} (N-m)	M _{PO} (N-m)	M _{VO} (N-m)					
33	8.7	18	40	4.5×7.5×5.3	7.5	15	1000	5600	11300	135	44	37	2.381	0.2	2.1		
37	10.5	22	50	4.5×7.5×5.3	7.5	15	1600	6450	13900	185	65.5	55	2.381	0.3	2.9		
42	15	24	60	4.5×7.5×5.3	9	20	2000	12800	26900	400	171	143	3.175	0.5	4.7		
69	19	40	80	7×11×9	14.5	20	2400	33000	66500	1690	645	545	4.762	1.5	9.6		
90	24	60	80	9×14×12	15	20	3000	61500	117000	3900	1530	1280	6.350	4.0	15.8		

Remarks: 1) The basic dynamic load rating is a load that furnishes 50 km rating fatigue life; it is a vertical and constant load to the ball slide mounting surface.
 When converting the basic dynamic load rating C to the dynamic load rating C₁₀₀ for 100 km rating fatigue life, divide the C by 1.26.