

A-5-1.3 LH Series

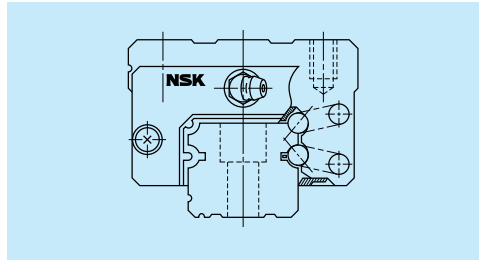
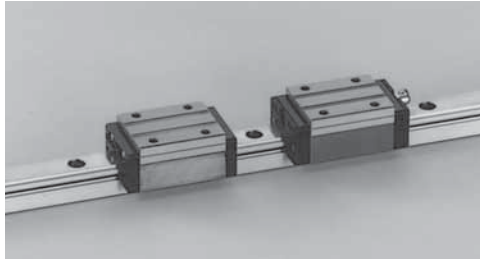

Fig. 1 LH Series

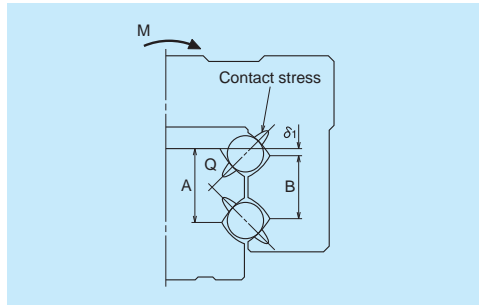

Fig. 2 Enlarged illustration of the offset Gothic arch groove

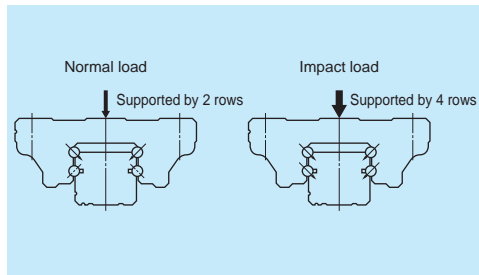

Fig. 3 When load is applied

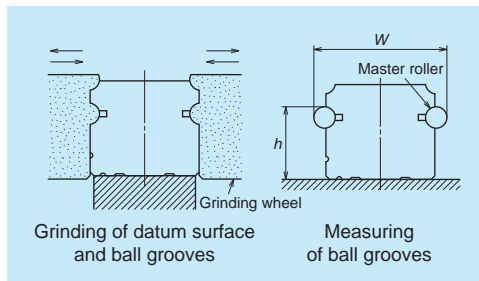

Fig. 4 Rail grinding and measuring

(1) Features

1. High self-aligning capability (rolling direction)

Same as the DF combination in angular contact bearings, self-aligning capability is high because the cross point of the contact lines of balls and grooves comes inside, reducing moment rigidity. This increases the capacity to absorb errors in installation.

2. High load carrying capacity to vertical direction

The contact angle is set at 50 degrees, increasing load carrying capacity as well as rigidity in vertical direction.

3. High resistance against impact load

The bottom ball groove is formed in Gothic arch and the center of the top and bottom grooves are offset as shown in Fig. 2. The vertical load is generally carried by the top rows, where balls are contacting at two points. Because of this design, the bottom rows will carry load when a large impact load is applied vertically as shown in Fig. 3. This assures high resistance to the impact load.

4. High accuracy

As showing in Fig. 4, fixing the master rollers is easy thanks to the Gothic arch groove. This makes easy and accurate measuring of ball grooves.

5. Easy to handle, and designed with safety in mind.

Balls are retained in the retainer, therefore they do not fall out when the ball slide is withdrawn from the rail. (LH10 to LH65)

6. Abundant models and sizes

Each series has various models of ball slides, rendering the linear guide available for numerous uses.

7. Fast delivery

Lineup of random-matching rails and ball slides supports and facilitates fast delivery. (LH15 to LH65)

(2) Ball slide shape

Ball slide Model	Shape/installation method	Type	
		High-load type	Super-high-load type
AN BN		AN 	BN 
AL BL		AL 	BL 
EL GL		EL 	GL 
FL HL		FL 	HL 
EM GM		EM 	GM 

(3) Accuracy and preload

1. Running parallelism of ball slide

Table 1

Unit:  $\mu\text{m}$

Rail over all length (mm) over or less	Preloaded assembly (not random matching)						Random-matching type
	Ultra precision P3	Super precision P4	High precision P5	Precision grade P6	Normal grade PN	Normal grade PC	
- 50	2	2	2	4.5	6	6	
50 - 80	2	2	3	5	6	6	
80 - 125	2	2	3.5	5.5	6.5	6.5	
125 - 200	2	2	4	6	7	7	
200 - 250	2	2.5	5	7	8	8	
250 - 315	2	2.5	5	8	9	9	
315 - 400	2	3	6	9	11	11	
400 - 500	2	3	6	10	12	12	
500 - 630	2	3.5	7	12	14	14	
630 - 800	2	4.5	8	14	16	16	
800 - 1000	2.5	5	9	16	18	18	
1000 - 1250	3	6	10	17	20	20	
1250 - 1600	4	7	11	19	23	23	
1600 - 2000	4.5	8	13	21	26	26	
2000 - 2500	5	10	15	22	29	29	
2500 - 3150	6	11	17	25	32	32	
3150 - 4000	9	16	23	30	34	34	

Note: LH08, 10, and 12 are not available in random matching. For LH08,10, and 12, P4, P5, P6, and PN grades are available.

2. Accuracy standard

The preloaded assembly has five accuracy grades; Ultra precision P3, Super precision P4, High precision P5, Precision P6 and Normal PN grades, while the random-matching type has Normal PC grade.

• Tolerance of preloaded assembly

Table 2

Unit:  $\mu\text{m}$

Characteristics	Accuracy grade	Ultra precision P3	Super precision P4	High precision P5	Precision grade P6	Normal grade PN	
Mounting height $H$ Variation of $H$ (All ball slides on a set of rails)		$\pm 10$ 3	LH08,10,12 LH15 - $\pm 10$ $\pm 10$ 3 5	LH08,10,12 LH15 - $\pm 20$ $\pm 20$ 5 7	LH08,10,12 LH15 - $\pm 40$ $\pm 40$ 7 15	LH08,10,12 LH15 - $\pm 80$ $\pm 80$ 15 25	
Mounting width $W_2$ or $W_3$ Variation of $W_2$ or $W_3$ (All ball slides on reference rail)		$\pm 15$ 3	LH08,10,12 LH15 - $\pm 10$ $\pm 15$ 5 7	LH08,10,12 LH15 - $\pm 15$ $\pm 25$ 7 10	LH08,10,12 LH15 - $\pm 25$ $\pm 50$ 10 20	LH08,10,12 LH15 - $\pm 50$ $\pm 100$ 20 30	
Running parallelism of face C to face A Running parallelism of face D to face B		Shown in Table 1, Fig. 5, and Fig. 6					

Note: For LH08, 10, and 12, accuracy of P4, P5, P6, and PN grades are available.

• Tolerance of random-matching type: Normal grade PC

Table 3

Unit:  $\mu\text{m}$

Characteristics	Model No.	LH15, 20, 25, 30, 35	LH45, 55, 65
Mounting height $H$		$\pm 20$	$\pm 30$
Variation of mounting height $H$		15① 30②	20① 35②
Mounting width $W_2$ or $W_3$		$\pm 30$	$\pm 35$
Variation of mounting width $W_2$ or $W_3$		25	30
Running parallelism of face C to face A Running parallelism of face D to face B		See Table 1, Fig. 5 and Fig. 6	

Note: 1) LH08, 10, 12 are not available in random matching. 2) ① Variation on the same rail ② Variation on multiple rails

3. Combinations of accuracy and preload

Table 4

	Accuracy grade					
	Ultra precision	Super precision	High precision	Precision grade	Normal grade	Normal grade
Without NSK K1 lubrication unit	P3	P4	P5	P6	PN	PC
With NSK K1 lubrication unit	K3	K4	K5	K6	KN	KC
With NSK K1 for food and medical equipment	F3	F4	F5	F6	FN	FC
Preload	Fine clearance Z0	○	○	○	○	—
	Slight preload Z1	○	○	○	○	—
	Medium preload Z3	○	○	○	○	—
	Random-matching type with fine clearance ZT	—	—	—	—	○
	Random-matching type with slight preload ZZ	—	—	—	—	○

4. Assembled accuracy

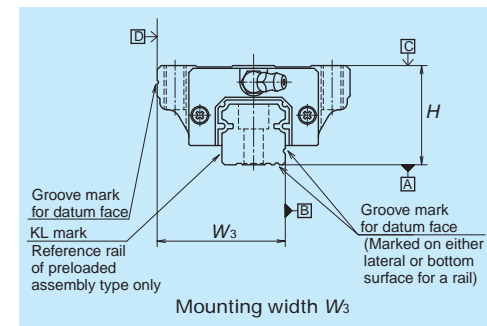
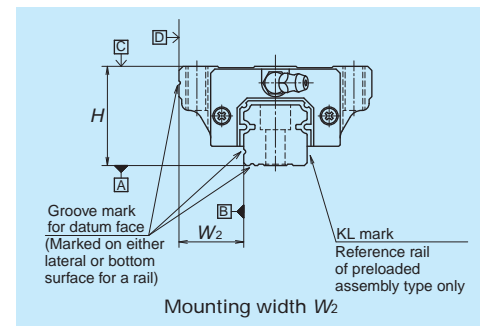

Fig. 5 Special high carbon steel

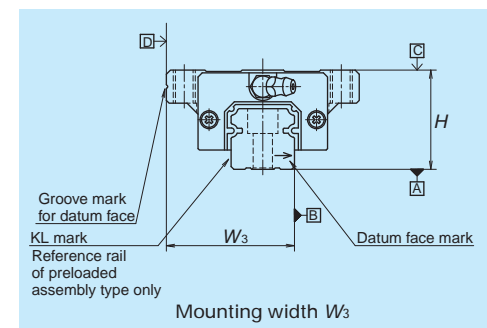
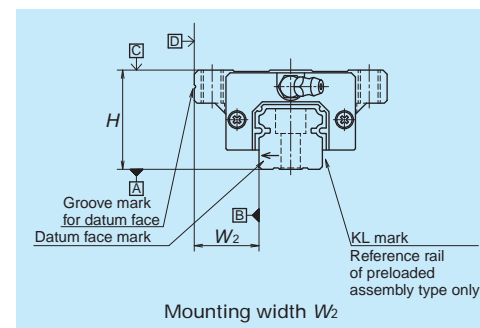

Fig. 6 Stainless steel

### 5. Preload and rigidity

We offer five levels of preload: slight preload Z1, medium preload Z3 and fine clearance Z0, along with random-matching type of fine clearance ZT and slight preload ZZ. Values for preload and rigidity of the preloaded assembly are shown in Table 5. Rigidities are for the median of the preload range.

• Preload and rigidity of preloaded assembly

Table 5

Model No.	Preload (N)		Rigidity (N/μm)			
			Vertical direction		Lateral direction	
	Slight preload Z1	Medium preload Z3	Slight preload Z1	Medium preload Z3	Slight preload Z1	Medium preload Z3
LH08 AN	5	—	33	—	23	—
LH10 AN	9	—	44	—	31	—
LH12 AN	22	—	68	—	47	—
LH15 AN, EL, FL, EM	78	490	137	226	98	186
LH20 AN, EL, FL, EM	147	835	186	335	137	245
LH25 AN, AL, EL, FL, EM	196	1270	206	380	147	284
LH30 AN, AL	245	1570	216	400	157	294
LH30 EL, FL, EM	294	1770	265	480	186	355
LH35 AN, AL, EL, FL, EM	390	2350	305	560	216	390
LH45 AN, AL, BL, EL, FL, EM	635	3900	400	745	284	540
LH55 AN, AL, EL, FL, EM	980	5900	490	910	345	645
LH65 AN, EL, FL, EM	1470	8900	580	1070	400	755
LH15 BN, GL, HL, GM	98	685	196	345	137	284
LH20 BN, GL, HL, GM	196	1080	265	480	196	355
LH25 BN, BL, GL, HL, GM	245	1570	294	560	216	400
LH30 BN, BL, GL, HL, GM	390	2260	360	665	265	480
LH35 BN, BL, GL, HL, GM	490	2940	430	795	305	570
LH45 BN, BL, GL, HL, GM	785	4800	520	960	370	695
LH55 BN, BL, GL, HL, GM	1180	7050	635	1170	440	835
LH65 BN, GL, HL, GM	1860	11300	805	1480	550	1040

Note: Clearance for fine clearance Z0 is 0 to 3μm. Therefore, preload is zero. However, Z0 of PN grade is 0 to 15μm.

• Clearance and preload of random-matching type

Table 6 Unit: μm

Model No.	Fine clearance ZT	Slight preload ZZ
LH15	-4 - 15	-4 - 0
LH20	-5 - 15	-5 - 0
LH25		-5 - 0
LH30		-7 - 0
LH35		-7 - 0
LH45		-7 - 0
LH55		-9 - 0
LH65		-9 - 0

Note: 1) Minus sign denotes that a value is an amount of preload (elastic deformation of balls).  
2) LH08, 10, and 12 are not available in random matching.

### (4) Available length of rail

Table 7 shows the limitations of rail length (maximum length). However, the limitations vary by accuracy grade.

Table 7 Length limitations of rails Unit: mm

Series	Material	Size										
		08	10	12	15	20	25	30	35	45	55	65
LH	Special high carbon steel				2000	3960	3960	4000	4000	3990	3960	3900
	Stainless steel	375	600	800	1800	3500	3500	3500				

Note: Rails can be butted if user requirement exceeds the rail length shown in the Table. Please consult NSK.

### (5) Installation

#### 1. Permissible values of mounting error

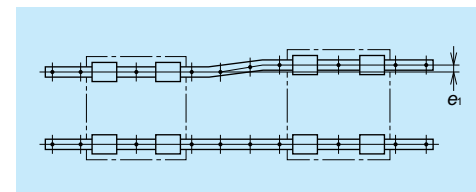

Fig. 7

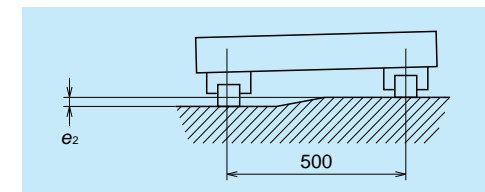

Fig. 8

Table 8 Unit: μm

Value	Preload	Model No.										
		LH08	LH10	LH12	LH15	LH20	LH25	LH30	LH35	LH45	LH55	LH65
Permissible values of parallelism in two rails $e_1$	Z0, ZT	9	12	19	22	30	40	45	55	65	80	110
	Z1, ZZ	8	11	18	18	20	25	30	35	45	55	70
	Z3	-	-	-	13	15	20	25	30	40	45	60
Permissible values of parallelism (height) in two rails $e_2$	Z0, ZT	375 μm/500 mm										
	Z1, ZZ, Z3	330 μm/500 mm										

#### 2. Shoulder height of the mounting face and corner radius r

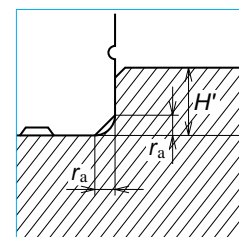

Fig. 9 Shoulder for the rail datum face

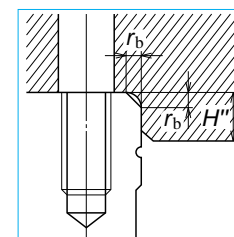

Fig. 10 Shoulder for the ball slide datum face

Table 9 Unit: mm

Model No.	Corner radius (maximum)		Shoulder height	
	$r_a$	$r_b$	$H'$	$H''$
LH08	0.3	0.5	1.8	3
LH10	0.3	0.5	2.1	4
LH12	0.5	0.5	2.7	4
LH15	0.5	0.5	4	4
LH20	0.5	0.5	4.5	5
LH25	0.5	0.5	5	5
LH30	0.5	0.5	6	6
LH35	0.5	0.5	6	6
LH45	0.7	0.7	8	8
LH55	0.7	0.7	10	10
LH65	1	1	11	11

## (6) Lubrication components

Refer to page A38 and D13 for the lubrication of linear guides.

### 1. Types of lubrication accessories

Figure 11 and Table 10 show grease fittings and tube fittings.

We provide lubrication accessories with extended thread body length (L) for the addition of dust proof accessories such as NSK K1 lubrication unit, double seal and protector.

We provide a suitable lubrication accessory for the special requirement on dust proof accessories.

Consult NSK for a lubrication accessory with extended length of thread body for your convenience of replenishing lubricant.

Please ask NSK for stainless lubrication accessories.

### 2. Mounting position of lubrication accessories

The standard position of grease fittings is the end face of ball slide. We mount them on a side of end cap for an option. (Fig. 12)

Please consult NSK for installation of grease or tube fittings to the ball slide body or side of end cap.

When using a piping unit with thread of M6×1, you require a connector to connect to a grease fitting mounting hole with M6 × 0.75. The connector is available from NSK.

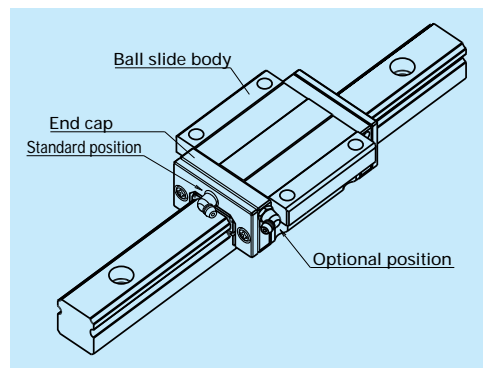

Fig. 12 Mounting position of lubrication accessories

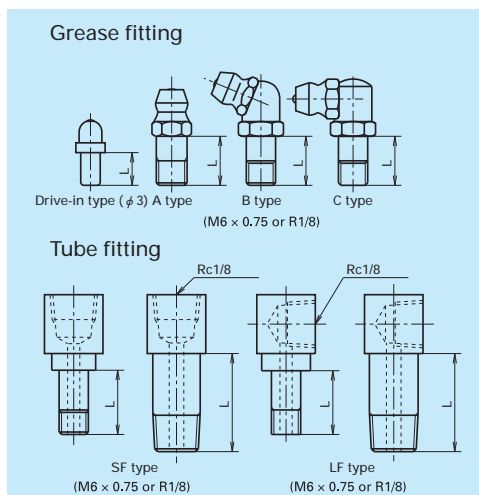

Fig. 11 Grease fitting and tube fitting

Model No.	Dust proof specification	Grease fitting	Tube fitting
		Thread body length L	Thread body length L
LH12	Standard	5	-
	With NSK K1	10	-
	Double seal	*	-
	Protector	*	-
LH15	Standard	5	-
	With NSK K1	10	-
	Double seal	*	-
	Protector	*	-
LH20	Standard	5	-
	With NSK K1	12	-
	Double seal	10	-
	Protector	10	-
LH25	Standard	5	6**
	With NSK K1	12	11**
	Double seal	10	9**
	Protector	10	9**
LH30	Standard	5	6
	With NSK K1	14	13
	Double seal	12	11
	Protector	12	11
LH35	Standard	5	6
	With NSK K1	14	13
	Double seal	12	11
	Protector	12	11
LH45	Standard	8	17
	With NSK K1	18	21.5
	Double seal	14	17
	Protector	14	17
LH55	Standard	8	17
	With NSK K1	18	21.5
	Double seal	14	17
	Protector	14	17
LH65	Standard	8	17
	With NSK K1	20	25.5
	Double seal	16	19
	Protector	16	17

\*) Please contact NSK as a connector is required.  
 \*\*) Only available for AN and BN type ball slides.

## (7) Dust proof components

### 1. Standard specification

To keep foreign matters from entering inside the ball slide, LH Series has an end seal on both ends, and bottom seals at the bottom.

However, the bottom seals are not used to LH08 and 10.

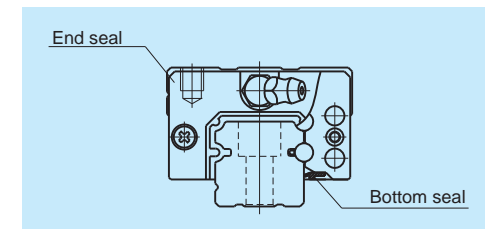

Fig. 13

Table 11 Seal friction per ball slide (maximum value)

Series	Size	Unit : N										
		08	10	12	15	20	25	30	35	45	55	65
LH		0.5	1	1.5	8	9	10	10	12	17	22	29

### 2. NSK K1™

Table 12 shows the dimension of linear guides equipped with the NSK K1.

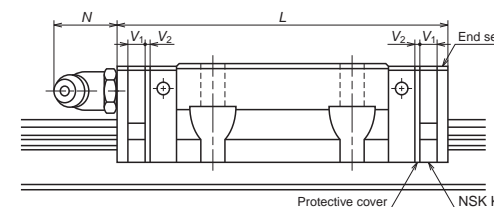

Table 12

Model No.	Ball slide length	Ball slide model	Standard ball slide length	Ball slide length installed with two NSK K1 L	Per NSK K1 thickness V <sub>1</sub>	Protective cover thickness V <sub>2</sub>	Protruding area of the grease fitting N
LH08	Standard	AN	24	31	3	0.5	—
LH10	Standard	AN	31	40	4	0.5	—
LH12	Standard	AN	45	54	4	0.5	(4)
LH15	Standard	AN, EL, FL, EM	55	65.6	4.5	0.8	(5)
	Long	BN, GL, HL, GM	74	84.6			
LH20	Standard	AN, EL, FL, EM	69.8	80.4	4.5	0.8	(14)
	Long	BN, GL, HL, GM	91.8	102.4			
LH25	Standard	AL, AN, EL, FL, EM	79.0	90.6	5.0	0.8	(14)
	Long	BL, BN, GL, HL, GM	107	118.6			
LH30	Standard	AL, AN	85.6	97.6	5.0	1.0	(14)
	Flange type	EL, FL, EM	98.6	110.6			
LH35	Standard	AL, AN, EL, FL, EM	109	122	5.5	1.0	(14)
	Long	BL, BN, GL, HL, GM	143	156			
LH45	Standard	AL, AN, EL, FL, EM	139	154	6.5	1.0	(15)
	Long	BL, BN, GL, HL, GM	171	186			
LH55	Standard	AL, AN, EL, FL, EM	163	178	6.5	1.0	(15)
	Long	BL, BN, GL, HL, GM	201	216			
LH65	Standard	AN, EL, FL, EM	193	211	8.0	1.0	(16)
	Long	BN, GL, HL, GM	253	271			

Note: 1) NSK K1 for food and medical equipments are available for LH12 to LH35.

2) Ball slide length equipped with NSK K1 = (Standard ball slide length) + (Thickness of NSK K1, V<sub>1</sub> × Number of NSK K1) + (Thickness of the protective cover, V<sub>2</sub> × 2)

### 3. Double seal

Use a double seal set as showing in Table 13, when installing an extra seal to completed standard products. (Fig. 14)

When installing a grease fitting after the installation of double seals, a connector is required.

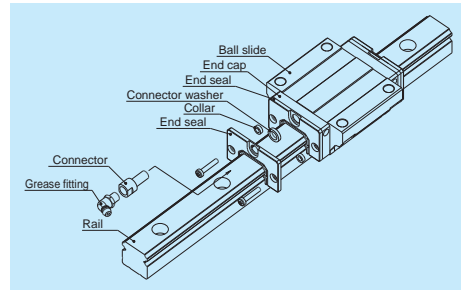

Fig. 14 Double seal

### 4. Protector

Use a protector set as showing Table 14, when installing a protector to completed standard products. (Fig.15)

When installing a grease fitting after the installation of protectors, a connector is required.

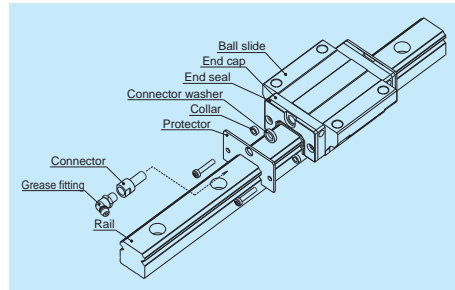

Fig. 15 Protector

Table 13 Double-seal set

Model No.	Reference No.		Increased thickness $V_1$
	Without connector	With connector	
LH15	LH15WS-01	*	2.5
LH20	LH20WS-01	LH20WSC-01	2.5
LH25	LH25WS-01	LH25WSC-01	2.8
LH30	LH30WS-01	LH30WSC-01	3.6
LH35	LH35WS-01	LH35WSC-01	3.6
LH45	LH45WS-01	LH45WSC-01	4.3
LH55	LH55WS-01	LH55WSC-01	4.3
LH65	LH65WS-01	LH65WSC-01	4.9

Table 14 Protector set

Model No.	Reference No.		Increased thickness $V_2$
	Without connector	With connector	
LH15	LH15PT-01	*	2.7
LH20	LH20PT-01	LH20PTC-01	2.9
LH25	LH25PT-01	LH25PTC-01	3.2
LH30	LH30PT-01	LH30PTC-01	4.2
LH35	LH35PT-01	LH35PTC-01	4.2
LH45	LH45PT-01	LH45PTC-01	4.9
LH55	LH55PT-01	LH55PTC-01	4.9
LH65	LH65PT-01	LH65PTC-01	5.5

\*) For installation of a connector to a drive-in type grease fitting, contact NSK.

Note: Double seal and protector for LH08, 10, and 12, please consult NSK.

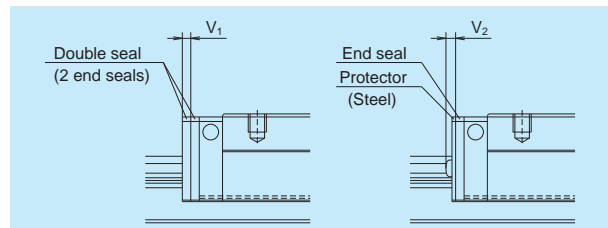

Fig. 16

### 5. Cap to cover the bolt hole for rail mounting

Table 15 Caps to cover rail bolt hole

Model No.	Bolt to secure rail	Cap reference No.	Quantity /case
LH10, LH12	M3	LG-CAP/M3	20
LH15	M4	LG-CAP/M4	20
LH20	M5	LG-CAP/M5	20
LH25	M6	LG-CAP/M6	20
LH30, LH35	M8	LG-CAP/M8	20
LH45	M12	LG-CAP/M12	20
LH55	M14	LG-CAP/M14	20
LH65	M16	LG-CAP/M16	20

### 7. Bellows

Use a bellows fastener kit as showing Table 17, when installing bellows to completed standard products. A bellows fastener kit is supplied with one of bellows fastener, two of M1 set screws, two of M2 set screws, and two collars for M2 set screw.

The bellows for LH08, 10, 12, and 15, please consult NSK.

### 6. Inner seal

Inner seal can be manufactured for models shown below.

Table 16

Series	Model No.
LH	LH20, LH25, LH30, LH35, LH45, LH55, LH65

Table 17 Bellows fastner kit reference No.

Model No.	Kit reference No.
LH20	LH20FS-01
LH25	LH25FS-01
LH30	LH30FS-01
LH35	LH35FS-01
LH45	LH45FS-01
LH55	LH55FS-01
LH65	LH65FS-01

Dimension tables of bellows  
LH Series

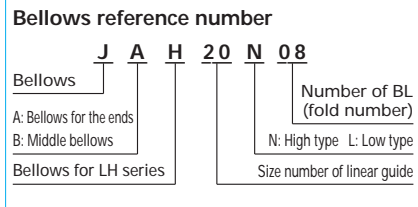
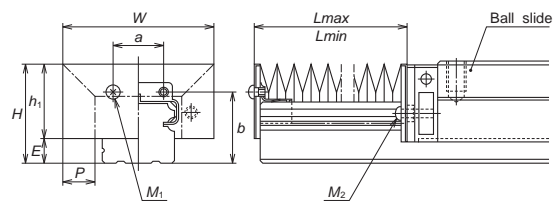

Fig. 17 Dimensions of bellows

Table 18 Dimensions of bellows

Unit: mm

Model No.	H	h <sub>1</sub>	E	W	P	a	b	BL minimum length	M <sub>1</sub> Tap x depth	M <sub>2</sub> Tap x depth
JAH20N	29.5	24.5	5	48	10	13	22	17	M3x5	M2.5x16
JAH25L	35	28	7	51	10	16	26	17	M3x5	M3x18
JAH25N	39	32		61	15					
JAH30L	41	32	9	60	12	18	31	17	M4x6	M4x22
JAH30N	44	35		66	15					
JAH35L	47	37.5	9.5	72	15	24	34	17	M4x6	M4x23
JAH35N	54	44.5		82	20					
JAH45L	59	45	14	83	15	32	44.5	17	M5x8	M5x28
JAH45N	69	55		103	25					
JAH55L	69	54	15	101	20	40	50.5	17	M5x8	M5x30
JAH55N	79	64		121	30					
JAH65N	89	73	16	131	30	48	61	17	M6x8	M6x35

Table 19 Numbers of folds (BL) and lengths of bellows

Unit: mm

Model No.	Number of BL	2	4	6	8	10	12	14	16	18	20
		L <sub>min</sub>	34	68	102	136	170	204	238	272	306
JAH20N	Stroke	106	212	318	424	530	636	742	848	954	1060
	L <sub>max</sub>	140	280	420	560	700	840	980	1120	1260	1400
JAH25L	Stroke	106	212	318	424	530	636	742	848	954	1060
	L <sub>max</sub>	140	280	420	560	700	840	980	1120	1260	1400
JAH25N	Stroke	176	352	528	704	880	1056	1232	1408	1584	1760
	L <sub>max</sub>	210	420	630	840	1050	1260	1470	1680	1890	2100
JAH30L	Stroke	134	268	402	536	670	804	938	1072	1206	1340
	L <sub>max</sub>	168	336	504	672	840	1008	1176	1344	1512	1680
JAH30N	Stroke	176	352	528	704	880	1056	1232	1408	1584	1760
	L <sub>max</sub>	210	420	630	840	1050	1260	1470	1680	1890	2100
JAH35L	Stroke	176	352	528	704	880	1056	1232	1408	1584	1760
	L <sub>max</sub>	210	420	630	840	1050	1260	1470	1680	1890	2100
JAH35N	Stroke	246	492	738	984	1230	1476	1722	1968	2214	2460
	L <sub>max</sub>	280	560	840	1120	1400	1680	1960	2240	2520	2800
JAH45L	Stroke	176	352	528	704	880	1058	1232	1408	1584	1760
	L <sub>max</sub>	210	420	630	840	1050	1260	1470	1680	1890	2100
JAH45N	Stroke	316	632	948	1264	1580	1896	2212	2528	2844	3160
	L <sub>max</sub>	350	700	1050	1400	1750	2100	2450	2800	3150	3500
JAH55L	Stroke	246	492	738	984	1230	1476	1722	1968	2214	2460
	L <sub>max</sub>	280	560	840	1120	1400	1680	1960	2240	2520	2800
JAH55N	Stroke	386	772	1158	1544	1930	2316	2702	3088	3474	3860
	L <sub>max</sub>	420	840	1260	1680	2100	2520	2940	3360	3780	4200
JAH65N	Stroke	386	772	1158	1544	1930	2316	2702	3088	3474	3860
	L <sub>max</sub>	420	840	1260	1680	2100	2520	2940	3360	3780	4200

Remarks: Values of odd numbers BL (3, 5, 7, ...) can be obtained by adding two values of even number BLs on both sides, then dividing the sum by two.

LH Series

(8) Reference number

Reference numbers shall be set to individual NSK linear guide when its specifications are finalized, and it is indicated on its specification drawing.  
Please specify the reference number, except design serial number, to identify the product when ordering, requiring estimates, or inquiring about specifications from NSK.

1. Reference number for preloaded assembly

**LH 30 1000 ANC 2 -\*\* P5 3**

Series name	Preload code (See page A164)
Size	Accuracy code (See Table 21)
Rail length (mm)	Design serial number
Ball slide shape code (See page A162)	Added to the reference number.
Material/surface treatment code (See Table 20)	Number of ball slides per rail

2. Reference number for random-matching type

**Ball slide**

**LAH 30 ANC -\*\*PCZ**

Random-matching ball slide series code LAH : LH Series random-matching ball slide	Preload code T: Fine clearance. Z: Slight preload (See page A164)
Size	Accuracy code : PC PC: Normal grade is only available
Ball slide shape code (See page A162)	Design serial number
Material/surface treatment code (See Table 20)	Added to the reference number.

**Rail**

**L1H30 1200 LCN -\*\* PC Z**

Random-matching rail series code L1H : LH Series random-matching rail	Preload code T: Fine clearance. Z: Slight preload (See page A164)
Size	Accuracy code : PC PC: Normal grade is only available
Rail length (mm)	Design serial number
Rail shape code: L L : Standard	Added to the reference number.
Material/surface treatment code (See Table 20)	*Butting rail specification N: Non-butting. L: Butting specification

\*Please consult with NSK for butting rail specification.

Reference number for assembly of random-matching ball slide and rail is the same as the coding of preloaded assembly. However, preload code is fine clearance "T" or slight preload "Z" (Refer to page A164).

Table 20 Material/surface treatment code

Code	Description
C	Special high carbon steel (NSK standard)
K	Stainless steel (LH08 to LH30 only)
D	Special high carbon steel with surface treatment
H	Stainless steel with surface treatment
Z	Other, special

Table 21 Accuracy code

Accuracy	Standard (Without NSK K1)	With NSK K1	With NSK K1 for food and medical equipment
Ultra precision grade	P3	K3	F3
Super precision grade	P4	K4	F4
High precision grade	P5	K5	F5
Precision grade	P6	K6	F6
Normal grade	PN	KN	FN
Normal grade (random-matching type)	PC	KC	FC

Note: Refer to Page A38 and A61 for NSK K1 lubrication unit.

(9) Dimensions

LH-AN (High-load type)

LH-BN (Super-high-load type)

**LH 30 1000 ANC 2 -\*\* P5 3**

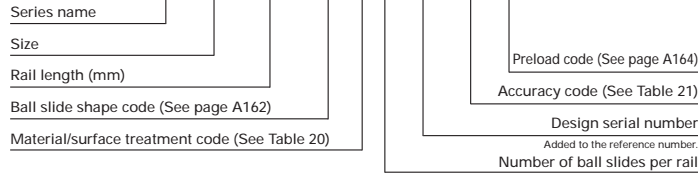

Front view of AN and BN types

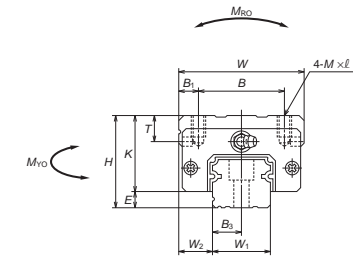

Side view of AN type

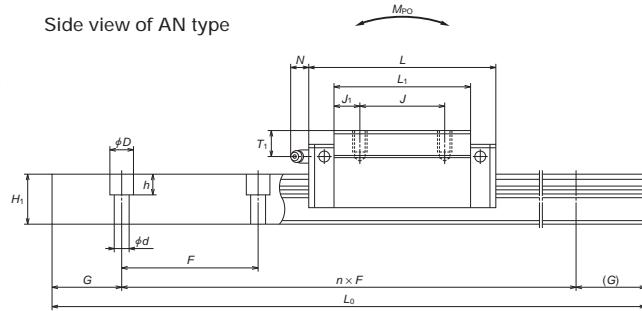

Side view of BN type

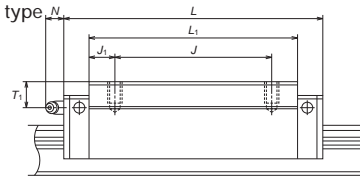

Reference number for ball slide of random-matching type

Ball slide **LAH 30 AN C -\*\* PC Z**

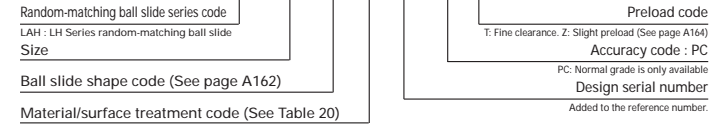

AN and BN types

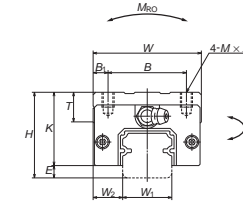

AN type

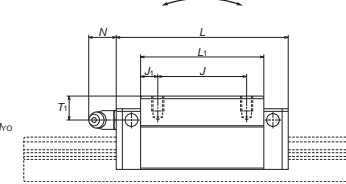

BN type

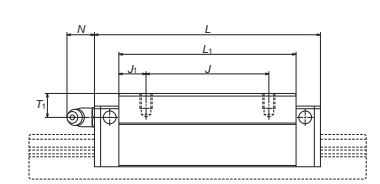

Reference number for rail of random-matching type

Rail **L1H 30 1200 L C N -\*\* PC Z**

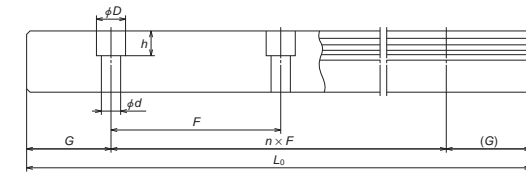
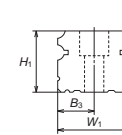
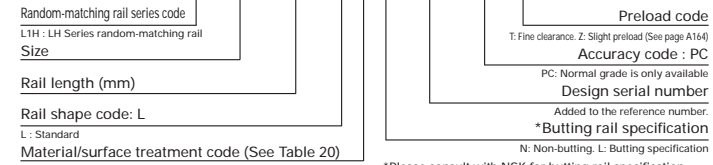

Unit: mm

Model No.	Assembly				Ball slide											Grease fitting		
	Height H	E	Width W <sub>2</sub>	Length W	Mounting hole					Ball slide					Hole size			
					B	J	M × pitch × l	B <sub>1</sub>	L <sub>1</sub>	J <sub>1</sub>	K	T	T <sub>1</sub>	N				
<b>LH08AN</b>	11	2.1	4	16	24	10	10	M2×0.4×2.5	3	15	2.5	8.9	—	—	—	—	—	—
<b>LH10AN</b>	13	2.4	5	20	31	13	12	M2.6×0.45×3	3.5	20.2	4.1	10.6	6	—	—	—	—	—
<b>LH12AN</b>	20	3.2	7.5	27	45	15	15	M4×0.7×5	6	31	8	16.8	6	φ 3	5	4	—	—
<b>LH15AN</b>	28	4.6	9.5	34	55	26	26	M4×0.7×6	4	39	6.5	23.4	8	φ 3	8.5	3.3	—	—
<b>LH15BN</b>					74					16								
<b>LH20AN</b>	30	5	12	44	69.8	32	36	M5×0.8×6	6	50	7	25	12	M6×0.75	5	11	—	—
<b>LH20BN</b>					91.8					11								
<b>LH25AN</b>	40	7	12.5	48	79	35	50	M6×1×9	6.5	58	11.5	33	12	M6×0.75	10	11	—	—
<b>LH25BN</b>					107					18								
<b>LH30AN</b>	45	9	16	60	85.6	40	40	M8×1.25×10	10	59	9.5	36	14	M6×0.75	10	11	—	—
<b>LH30BN</b>					124.6					19								
<b>LH35AN</b>	55	9.5	18	70	109	50	50	M8×1.25×12	10	80	15	45.5	15	M6×0.75	15	11	—	—
<b>LH35BN</b>					143					21								
<b>LH45AN</b>	70	14	20.5	86	139	60	60	M10×1.5×17	13	105	22.5	56	17	Rc1/8	20	13	—	—
<b>LH45BN</b>					171					28.5								
<b>LH55AN</b>	80	15	23.5	100	163	75	75	M12×1.75×18	12.5	126	25.5	65	18	Rc1/8	21	13	—	—
<b>LH55BN</b>					201					34.5								
<b>LH65AN</b>	90	16	31.5	126	193	76	70	M16×2×20	25	147	38.5	74	23	Rc1/8	19	13	—	—
<b>LH65BN</b>					253					43.5								

Remarks : 1) LH08 does not have a ball retainer. Be aware that balls fall out when the ball slide is withdrawn from the rail.  
 2) The external appearance of stainless steel ball slides differs from those of standard material ball slide.  
 3) Only stainless steel models are available for LH08 to LH12.

Rail							Basic load rating					Ball dia.	Weight	
Width W <sub>1</sub>	Height H <sub>1</sub>	Pitch F	Mounting bolt hole d × D × h	B <sub>3</sub>	G	Max. length L <sub>0max</sub> ( ) for stainless	Dynamic C (N)	Static C <sub>0</sub> (N)	Static moment			D <sub>W</sub>	Ball slide	Rail
							M <sub>RO</sub> (N·m)	M <sub>PO</sub> (N·m)	M <sub>VO</sub> (N·m)	(kg)	(kg/m)			
8	5.5	20	2.4×4.2×2.3	4	7.5	(375)	1240	2630	7.25	4.55	3.8	1.2000	0.013	0.31
10	6.5	25	3.5×6×3.5	5	10	(600)	2250	4500	16.2	10.5	8.8	1.5875	0.026	0.44
12	10.5	40	3.5×6×4.5	6	15	(800)	5650	11300	47.5	41.5	35	2.3812	0.082	0.88
15	15	60	4.5×7.5×5.3	7.5	20	2000 (1800)	10800 (14600)	20700 (32000)	108 (166)	94.5 (216)	79.5 (181)	3.175	0.18 (0.26)	1.6
20	18	60	6×9.5×8.5	10	20	3960 (3500)	17400 (23500)	32500 (50500)	219 (340)	185 (420)	155 (355)	3.968	0.33 (0.48)	2.6
23	22	60	7×11×9	11.5	20	3960 (3500)	25600 (34500)	46000 (71000)	360 (555)	320 (725)	267 (610)	4.762	0.55 (0.82)	3.6
28	26	80	9×14×12	14	20	4000 (3500)	31000 (46000)	51500 (91500)	490 (870)	350 (1030)	292 (865)	5.556	0.77 (1.3)	5.2
34	29	80	9×14×12	17	20	4000	47500 (117000)	80500 (138000)	950 (1380)	755 (1530)	630 (1280)	6.350	1.5 (2.1)	7.2
45	38	105	14×20×17	22.5	22.5	3990	81000 (187000)	140000 (286000)	2140 (2860)	1740 (3000)	1460 (2520)	7.937	3.0 (3.9)	12.3
53	44	120	16×23×20	26.5	30	3960	119000 (264000)	198000 (485000)	3600 (4850)	3000 (5150)	2510 (4350)	9.525	4.7 (6.1)	16.9
63	53	150	18×26×22	31.5	35	3900	181000 (235000)	281000 (410000)	6150 (8950)	4950 (10100)	4150 (8450)	11.906	7.7 (10.8)	24.3

4) The basic dynamic load rating is a load that furnishes 50 km rating fatigue life; it is a vertical and constant load to the ball slide mounting surface. When converting the basic dynamic load rating C to the dynamic load rating C<sub>100</sub> for 100 km rating fatigue life, divide the C by 1.26.  
 5) Random matching is available for LH15 to LH65.

LH-AL (High-load type)  
LH-BL (Super-high-load type)

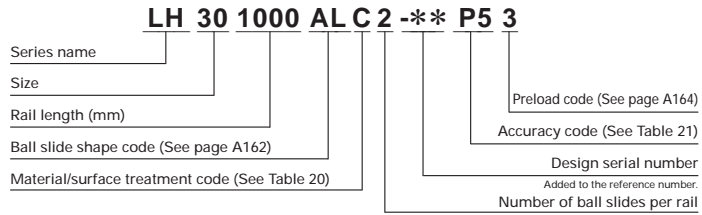

Front view of AL and BL types

Side view of AL type

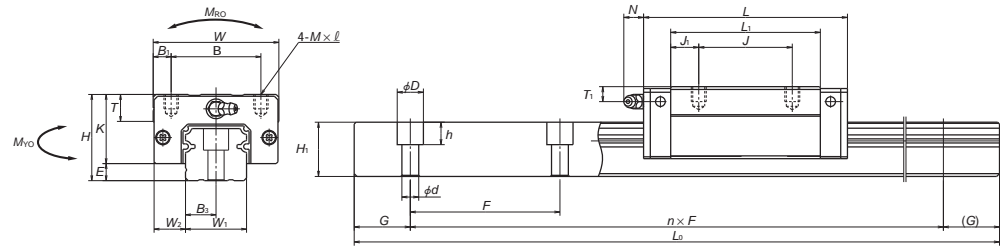

Side view of BL type

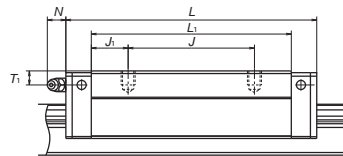

Reference number for ball slide of random-matching type

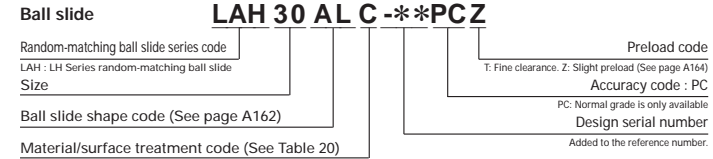

AL and BL types

AL type

BL type

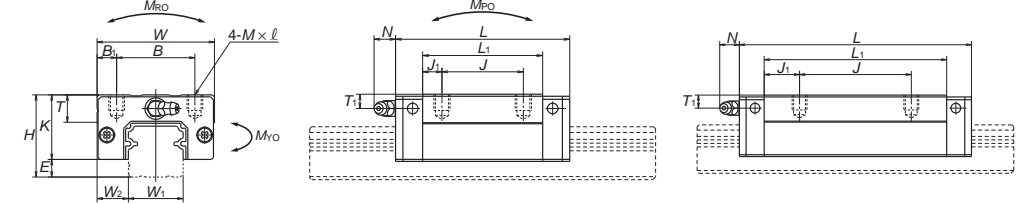

Reference number for rail of random-matching type

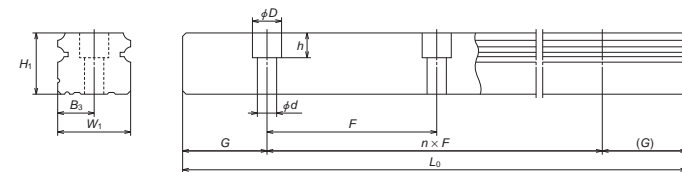
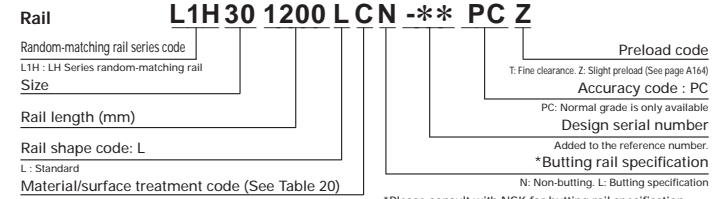

Model No.	Assembly			Ball slide										Grease fitting			
	Height $H$	$E$	$W_2$	Width $W$	Length $L$	Mounting hole					$B_1$	$L_1$	$J_1$	$K$	$T$	Hole size	
						$B$	$J$	$M \times \text{pitch} \times \ell$	$T_1$	$N$							
LH25AL LH25BL	36	7	12.5	48	79 107	35	35 50	M6×1×6	6.5	58 86	11.5 18	29	12	M6×0.75	6	11	
LH30AL LH30BL	42	9	16	60	85.6 124.6	40	40 60	M8×1.25×8	10	59 98	9.5 19	33	14	M6×0.75	7	11	
LH35AL LH35BL	48	9.5	18	70	109 143	50	50 72	M8×1.25×8	10	80 114	15 21	38.5	15	M6×0.75	8	11	
LH45AL LH45BL	60	14	20.5	86	139 171	60	60 80	M10×1.5×10	13	105 137	22.5 28.5	46	17	Rc1/8	10	13	
LH55AL LH55BL	70	15	23.5	100	163 201	75	75 95	M12×1.75×13	12.5	126 164	25.5 34.5	55	15	Rc1/8	11	13	

Remarks : 1) The external appearance of stainless steel ball slides differs from those of standard material ball slide.

Rail										Basic load rating					Ball dia.	Weight	
Width $W_1$	Height $H_1$	Pitch $F$	Mounting bolt hole $d \times D \times h$	$B_3$	$G$	Max. length $L_{0max}$ ( ) for stainless	Dynamic $C$ (N)	Static $C_0$ (N)	Static moment			$D_w$	Ball slide (kg)	Rail (kg/m)			
									$M_{ro}$ (N·m)	$M_{v0}$ (N·m)	$M_{v0}$ (N·m)						
23	22	60	7×11×9	11.5	20	3960 (3500)	25600 34500	46000 71000	360 555	320 725	267 610	4.762	0.46 0.69	3.6			
28	26	80	9×14×12	14	20	4000 (3500)	31000 46000	51500 91500	490 870	350 1030	292 865	5.556	0.69 1.16	5.2			
34	29	80	9×14×12	17	20	4000	47500 61500	80500 117000	950 1380	755 1530	630 1280	6.350	1.2 1.7	7.2			
45	38	105	14×20×17	22.5	22.5	3990	81000 99000	140000 187000	2140 2860	1740 3000	1460 2520	7.937	2.2 2.9	12.3			
53	44	120	16×23×20	26.5	30	3960	119000 146000	198000 264000	3600 4850	3000 5150	2510 4350	9.525	3.7 4.7	16.9			

2) The basic dynamic load rating is a load that furnishes 50 km rating fatigue life; it is a vertical and constant load to the ball slide mounting surface.  
When converting the basic dynamic load rating  $C$  to the dynamic load rating  $C_{100}$  for 100 km rating fatigue life, divide the  $C$  by 1.26.

LH-EL (High-load type)  
LH-GL (Super-high-load type)

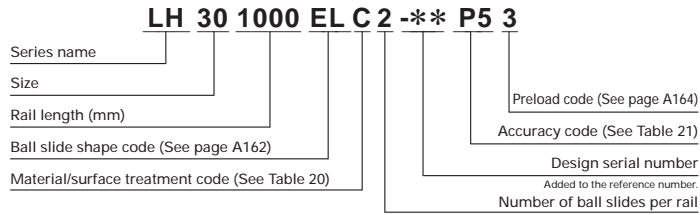

Front view of EL and GL types

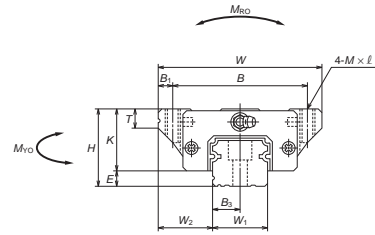

Side view of EL type

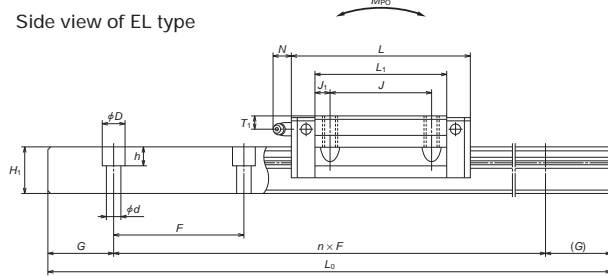

Side view of GL type

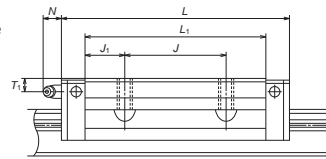

Reference number for ball slide of random-matching type

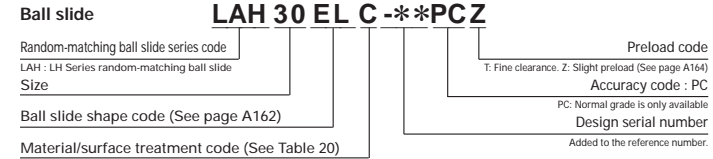

EL and GL types

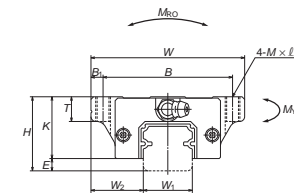

EL type

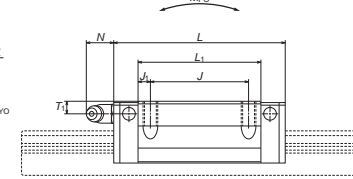

GL type

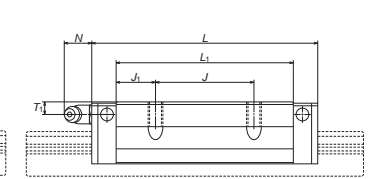

Reference number for rail of random-matching type

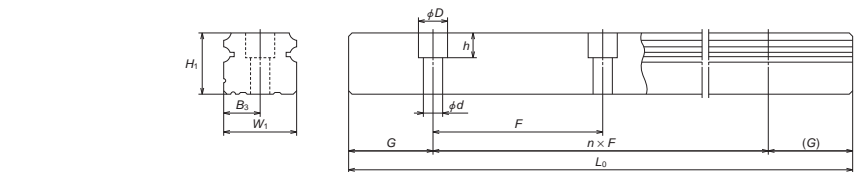
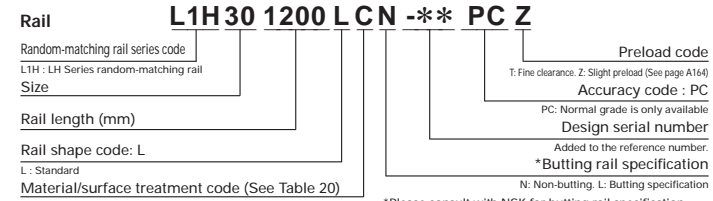

Model No.	Assembly			Ball slide													
	Height H	E	W <sub>2</sub>	Width W	Length L	Mounting hole					Grease fitting						
						B	J	M × pitch × l	B <sub>1</sub>	L <sub>1</sub>	J <sub>1</sub>	K	T	Hole size	T <sub>1</sub>	N	
LH15EL LH15GL	24	4.6	16	47	55 74	38	30	M5×0.8×8	4.5	39 58	4.5 14	19.4	8	φ 3	4.5	3.3	
LH20EL LH20GL	30	5	21.5	63	69.8 91.8	53	40	M6×1×10	5	50 72	5 16	25	10	M6×0.75	5	11	
LH25EL LH25GL	36	7	23.5	70	79 107	57	45	M8×1.25×16 (M8×1.25×12)	6.5	58 86	6.5 20.5	29	11 (12)	M6×0.75	6	11	
LH30EL LH30GL	42	9	31	90	98.6 124.6	72	52	M10×1.5×18 (M10×1.5×15)	9	72 98	10 23	33	11 (15)	M6×0.75	7	11	
LH35EL LH35GL	48	9.5	33	100	109 143	82	62	M10×1.5×20	9	80 114	9 26	38.5	12	M6×0.75	8	11	
LH45EL LH45GL	60	14	37.5	120	139 171	100	80	M12×1.75×24	10	105 137	12.5 28.5	46	13	Rc1/8	10	13	
LH55EL LH55GL	70	15	43.5	140	163 201	116	95	M14×2×28	12	126 164	15.5 34.5	55	15	Rc1/8	11	13	
LH65EL LH65GL	90	16	53.5	170	193 253	142	110	M16×2×24	14	147 207	18.5 48.5	74	23	Rc1/8	19	13	

Remarks: 1) Parenthesized dimensions are for items made of stainless steel.  
 2) The external appearance of stainless steel ball slides differs from those of standard material ball slide.

Unit: mm

Rail										Basic load rating					Ball dia. D <sub>w</sub>	Weight	
Width W <sub>1</sub>	Height H <sub>1</sub>	Pitch F	Mounting bolt hole d × D × h	B <sub>3</sub>	G	Max. length L <sub>0max</sub> ( ) For stainless	Dynamic C (N)	Static C <sub>0</sub> (N)	Static moment			Ball slide (kg)	Rail (kg/m)				
							C	C <sub>0</sub>	M <sub>RO</sub>	M <sub>PO</sub>	M <sub>VO</sub>						
15	15	60	4.5×7.5×5.3	7.5	20	2000 (1800)	10800 14600	20700 32000	108 166	94.5 216	79.5 181	3.175	0.17 0.25	1.6			
20	18	60	6×9.5×8.5	10	20	3960 (3500)	17400 23500	32500 50500	219 340	185 420	155 355	3.968	0.45 0.65	2.6			
23	22	60	7×11×9	11.5	20	3960 (3500)	25600 34500	46000 71000	360 555	320 725	267 610	4.762	0.63 0.93	3.6			
28	26	80	9×14×12	14	20	4000 (3500)	35500 46000	63000 91500	600 870	505 1030	425 865	5.556	1.2 1.6	5.2			
34	29	80	9×14×12	17	20	4000	47500 61500	80500 117000	950 1380	755 1530	630 1280	6.350	1.7 2.4	7.2			
45	38	105	14×20×17	22.5	22.5	3990	81000 99000	140000 187000	2140 2860	1740 3000	1460 2520	7.937	3.0 3.9	12.3			
53	44	120	16×23×20	26.5	30	3960	119000 146000	198000 264000	3600 4850	3000 5150	2510 4350	9.525	5.0 6.5	16.9			
63	53	150	18×26×22	31.5	35	3900	181000 235000	281000 410000	6150 8950	4950 10100	4150 8450	11.906	10.0 14.1	24.3			

3) The basic dynamic load rating is a load that furnishes 50 km rating fatigue life; it is a vertical and constant load to the ball slide mounting surface. When converting the basic dynamic load rating C to the dynamic load rating C<sub>100</sub> for 100 km rating fatigue life, divide the C by 1.26.

LH-FL (High-load type)  
LH-HL (Super-high-load type)

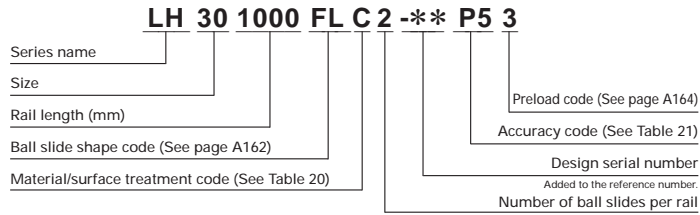

Front view of FL and HL types

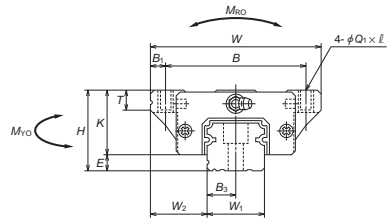

Side view of FL type

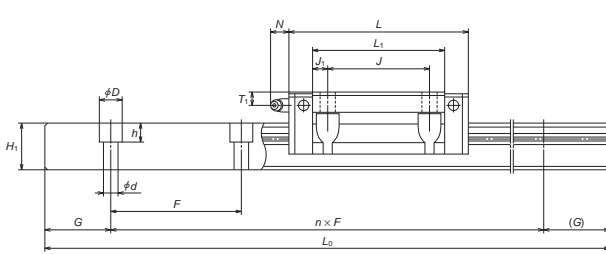

Side view of HL type

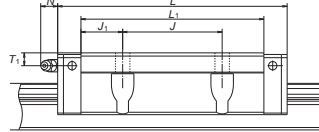

Model No.	Assembly			Ball slide											Grease fitting			
	Height H	E	W <sub>2</sub>	Width W	Length L	Mounting hole					B <sub>1</sub>	L <sub>1</sub>	J <sub>1</sub>	K	T	Hole size	T <sub>1</sub>	N
						B	J	Q <sub>1</sub> × l										
LH15FL LH15HL	24	4.6	16	47	55 74	38	30	4.5×7		4.5	39 58	4.5 14	19.4	8	φ3	4.5	3.3	
LH20FL LH20HL	30	5	21.5	63	69.8 91.8	53	40	6×9.5		5	50 72	5 16	25	10	M6×0.75	5	11	
LH25FL LH25HL	36	7	23.5	70	79 107	57	45	7×10 (7×11.5)		6.5	58 86	6.5 20.5	29	11 (12)	M6×0.75	6	11	
LH30FL LH30HL	42	9	31	90	98.6 124.6	72	52	9×12 (9×14.5)		9	72 98	10 23	33	11 (15)	M6×0.75	7	11	
LH35FL LH35HL	48	9.5	33	100	109 143	82	62	9×13		9	80 114	9 26	38.5	12	M6×0.75	8	11	
LH45FL LH45HL	60	14	37.5	120	139 171	100	80	11×15		10	105 137	12.5 28.5	46	13	Rc1/8	10	13	
LH55FL LH55HL	70	15	43.5	140	163 201	116	95	14×18		12	126 164	15.5 34.5	55	15	Rc1/8	11	13	
LH65FL LH65HL	90	16	53.5	170	193 253	142	110	16×24		14	147 207	18.5 48.5	74	23	Rc1/8	19	13	

Remarks: 1) Parenthesized dimensions are for items made of stainless steel.  
 2) The external appearance of stainless steel ball slides differs from those of standard material ball slide.

Reference number for ball slide of random-matching type

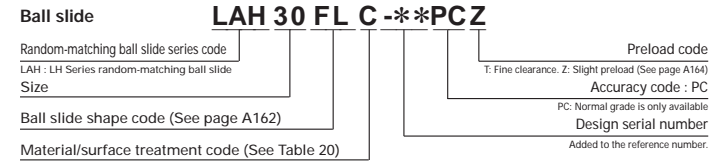

FL and HL types

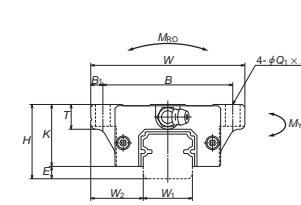

FL type

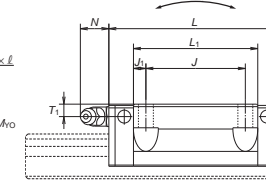

HL type

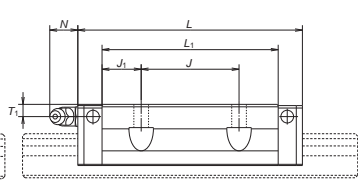

Reference number for rail of random-matching type

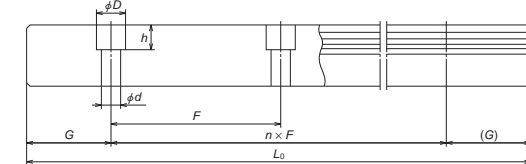
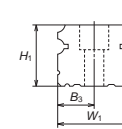
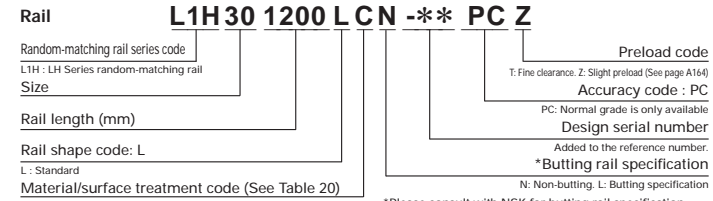

Rail								Basic load rating					Ball dia.		Weight	
Width W <sub>1</sub>	Height H <sub>1</sub>	Pitch F	Mounting bolt hole d × D × h	B <sub>3</sub>	G (reference)	Max. length L <sub>0max</sub> ( ) for stainless	Dynamic C (N)	Static C <sub>0</sub> (N)	Static moment			D <sub>w</sub>	Ball slide (kg)	Rail (kg/m)		
									M <sub>RO</sub> (N·m)	M <sub>PO</sub> (N·m)	M <sub>VO</sub> (N·m)					
15	15	60	4.5×7.5×5.3	7.5	20	2000 (1800)	10800 14600	20700 32000	108 166	94.5 216	79.5 181	3.175	0.17 0.25	1.6		
20	18	60	6×9.5×8.5	10	20	3960 (3500)	17400 23500	32500 50500	219 340	185 420	155 355	3.968	0.45 0.65	2.6		
23	22	60	7×11×9	11.5	20	3960 (3500)	25600 34500	46000 71000	360 555	320 725	267 610	4.762	0.63 0.93	3.6		
28	26	80	9×14×12	14	20	4000 (3500)	35500 46000	63000 91500	600 870	505 1030	425 865	5.556	1.2 1.6	5.2		
34	29	80	9×14×12	17	20	4000	47500 61500	80500 117000	950 1380	755 1530	630 1280	6.35	1.7 2.4	7.2		
45	38	105	14×20×17	22.5	22.5	3990	81000 99000	140000 187000	2140 2860	1740 3000	1460 2520	7.937	3 3.9	12.3		
53	44	120	16×23×20	26.5	30	3990	119000 146000	198000 264000	3600 4850	3000 5150	2510 4350	9.525	5 6.5	16.9		
63	53	150	18×26×22	31.5	35	3900	181000 235000	281000 410000	6150 8950	4950 10100	4150 8450	11.906	10 14.1	24.3		

3) The basic dynamic load rating is a load that furnishes 50 km rating fatigue life; it is a vertical and constant load to the ball slide mounting surface. When converting the basic dynamic load rating C to the dynamic load rating C<sub>100</sub> for 100 km rating fatigue life, divide the C by 1.26.

LH-EM (High-load type)  
LH-GM (Super-high-load type)

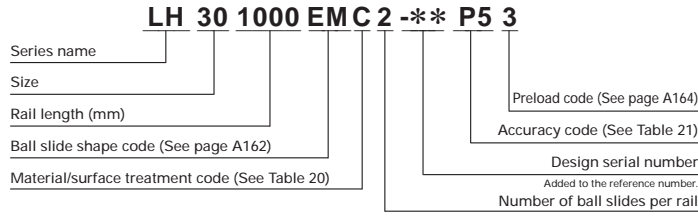

Front view of EM and GM types

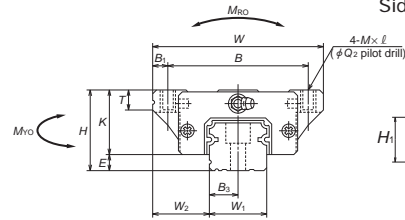

Side view of EM type

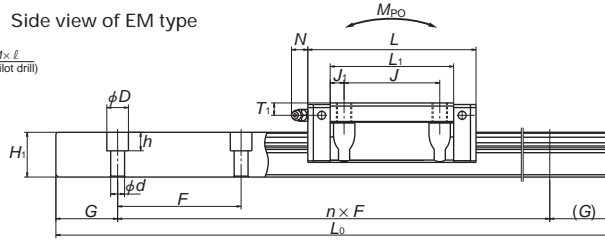

Side view of GM type

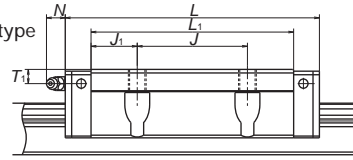

Reference number for ball slide of random-matching type

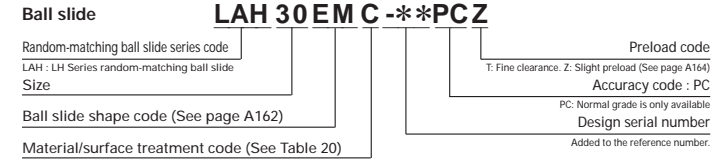

EM and GM types

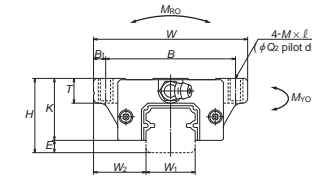

EM type

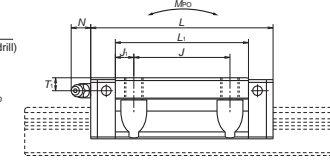

GM type

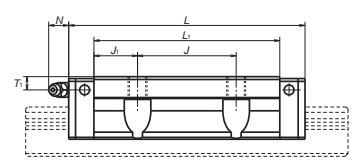

Reference number for rail of random-matching type

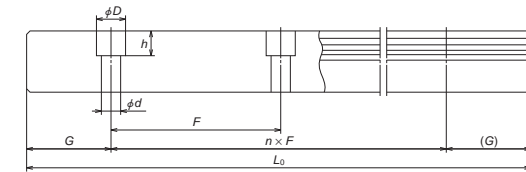
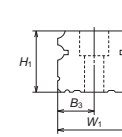
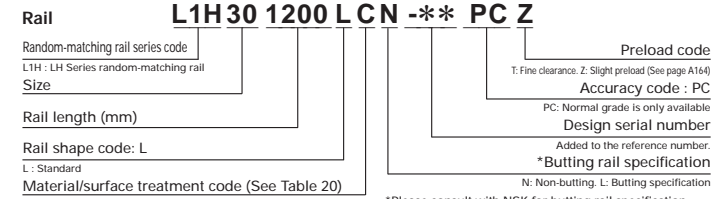

Unit: mm

Model No.	Assembly			Ball slide													
	Height H	E	W <sub>2</sub>	Width W	Length L	Mounting hole						Grease fitting					
						B	J	M × pitch × ℓ	Q <sub>2</sub>	B <sub>1</sub>	L <sub>1</sub>	J <sub>1</sub>	K	T	Hole size	T <sub>1</sub>	N
LH15EM LH15GM	24	4.6	16	47	55 74	38	30	M5×0.8×7	4.4	4.5	39 58	4.5 14	19.4	8	φ3	4.5	3.3
LH20EM LH20GM	30	5	21.5	63	69.8 91.8	53	40	M6×1×9.5	5.3	5	50 72	5 16	25	10	M6×0.75	5	11
LH25EM LH25GM	36	7	23.5	70	79 107	57	45	M8×1.25×10 (M8×1.25×11.5)	6.8	6.5	58 86	6.5 20.5	29	11 (12)	M6×0.75	6	11
LH30EM LH30GM	42	9	31	90	98.6 124.6	72	52	M10×1.5×12 (M10×1.5×14.5)	8.6	9	72 98	10 23	33	11 (15)	M6×0.75	7	11
LH35EM LH35GM	48	9.5	33	100	109 143	82	62	M10×1.5×13	8.6	9	80 114	9 26	38.5	12	M6×0.75	8	11
LH45EM LH45GM	60	14	37.5	120	139 171	100	80	M12×1.75×15	10.5	10	105 137	12.5 28.5	46	13	Rc1/8	10	13
LH55EM LH55GM	70	15	43.5	140	163 201	116	95	M14×2×18	12.5	12	126 164	15.5 34.5	55	15	Rc1/8	11	13
LH65EM LH65GM	90	16	53.5	170	193 253	142	110	M16×2×24	14.6	14	147 207	18.5 48.5	74	23	Rc1/8	19	13

Remarks: 1) Parenthesized dimensions are for items made of stainless steel.  
 2) The external appearance of stainless steel ball slides differs from those of standard material ball slide.

Rail								Basic load rating					Ball dia.		Weight	
Width W <sub>1</sub>	Height H <sub>1</sub>	Pitch F	Mounting bolt hole d × D × h	B <sub>3</sub>	G (reference)	Max. length L <sub>max</sub> ( <sup>○</sup> ) for stainless	Dynamic C (N)	Static C <sub>0</sub> (N)	Static moment			D <sub>w</sub>	Ball slide (kg)	Rail (kg/m)		
									M <sub>RO</sub> (N·m)	M <sub>PO</sub> (N·m)	M <sub>VO</sub> (N·m)					
15	15	60	4.5×7.5×5.3	7.5	20	2000 (1800)	10800 14600	20700 32000	108 166	94.5 216	79.5 181	3.175	0.17 0.25	1.6		
20	18	60	6×9.5×8.5	10	20	3960 (3500)	17400 23500	32500 50500	219 340	185 420	155 355	3.968	0.45 0.65	2.6		
23	22	60	7×11×9	11.5	20	3960 (3500)	25600 34500	46000 71000	360 555	320 725	267 610	4.762	0.63 0.93	3.6		
28	26	80	9×14×12	14	20	4000 (3500)	35500 46000	63000 91500	600 870	505 1030	425 865	5.556	1.2 1.6	5.2		
34	29	80	9×14×12	17	20	4000	47500 61500	80500 117000	950 1380	755 1530	630 1280	6.35	1.7 2.4	7.2		
45	38	105	14×20×17	22.5	22.5	3990	81000 99000	140000 187000	2140 2860	1740 3000	1460 2520	7.937	3 3.9	12.3		
53	44	120	16×23×20	26.5	30	3990	119000 146000	198000 264000	3600 4850	3000 5150	2510 4350	9.525	5 6.5	16.9		
63	53	150	18×26×22	31.5	35	3900	181000 235000	281000 410000	6150 8950	4950 10100	4150 8450	11.906	10 14.1	24.3		

3) The basic dynamic load rating is a load that furnishes 50 km rating fatigue life; it is a vertical and constant load to the ball slide mounting surface. When converting the basic dynamic load rating C to the dynamic load rating C<sub>10</sub> for 100 km rating fatigue life, divide the C by 1.26.