

Model LB-K (Open type)

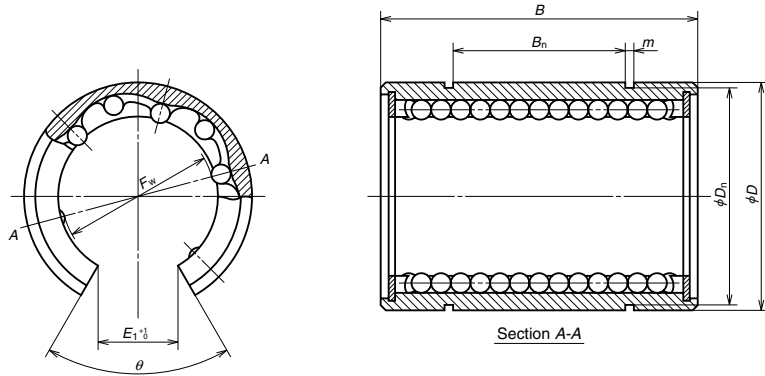

Unit: mm

Model No.	Inscribed circle diameter $F_w$	Outside diameter $D$	Length $B$	Opening width $E_1$	Opening angle $\theta$	Retaining ring groove			Number of ball circuit	Weight (kg) (Reference only)	Basic dynamic load rating $C$ (N)	Basic static load rating $C_0$ (N)
						Distance $B_n$	Width $m$	Bottom diameter $D_n$				
LB20NKY	20	32	42	11	60°	27	1.65	30.3	4	0.072	610	1010
LB25NKY	25	40	59	13	50°	37	1.9	38	5	0.220	1000	1960
LB30NKY	30	45	64	15	50°	40	1.9	42.5	5	0.260	1400	2500
LB35NKY	35	52	70	17	50°	45	2.2	49	5	0.370	1510	2800
LB40NKY	40	60	80	20	50°	56	2.2	57	5	0.440	2230	4000
LB50NKY	50	80	100	25	50°	68	2.7	76.5	5	1.480	4100	7100

A-III-2 Crossed Roller Guide

A-III-2.1 Structure

Rollers with a retainer (hereinafter refer to as "retainer") are assembled in a pair of rails which have a V-shape groove. ( the grooves form a 90-degree angle. Refer to Fig. III-2-1, III-2-2). Rollers are placed crisscrossed, and are able to support load in all directions, including moment loads.

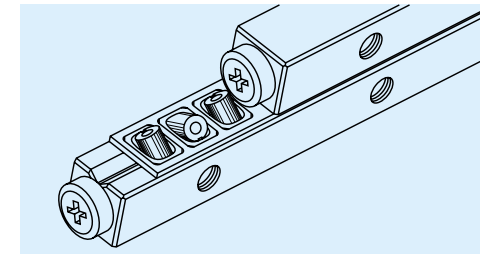

Fig. III-2-1 Structure of crossed roller guide

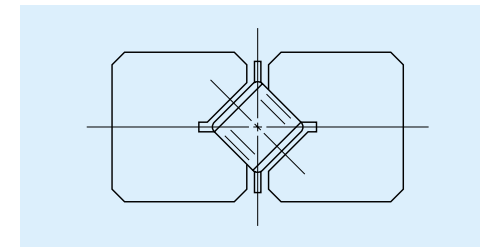

Fig. III-2-2 Cross section of a crossed roller guide

A-III-2.2 Features

- (1) **High rigidity**  
This is attributable to the long contact area between the rollers and their accurately ground rolling surface.
- (2) **Superbly smooth movement, low noise**  
The window which directly embraces the roller is made of plastic for smooth and quiet operation, lowering clatter when the retainer and the rollers come into contact.
- (3) **Less micro-slip**  
Occasionally, a minute continuous slippage of the retainer to one one direction, called "micro-slip," is caused due to installation error of the rail. After years of testing and research, NSK has developed technology to minimize this.
- (4) **Easy installation**  
Installation is easy because the rail bending is

minimal, and the bolt hole pitch for installation is precise.

(5) **Long durability**

The material is vacuum-degassed and highly pure, and is hardened by carburized heat treatment for superb resistance to wear and fatigue.

A-III-2.3 Accuracy

Accuracy grade P5 super precision and high precision grade P6 are available.

Fig. III-2-3 shows parallelism of the roller's rolling surface to the mounting datum face.

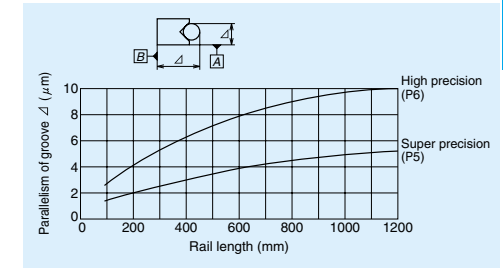

Fig. III-2-3 Parallelism of the roller rolling surface

A-III-2.4 Rigidity

The number of the load rollers changes by the direction of the load. This is because the rollers are positioned crisscross.

That is, in case of Fig. III-2-4:

The number of load rollers =  $1/2 \times$  total roller number .....(1)

In case of Fig. III-2-5:

The number of load rollers = Total roller number .....(2)

Fig. III-2-6 shows changes in elastic deformation when there are 20 load rollers. If the total number of rollers is other than 20, use the graph in Fig. III-2-7. Obtain the compensation factor which converts the elastic deformation value at time of 20 load rollers into the value when a specific number of rollers are loaded. That is, obtain a compensation factor on the ordinate that correspond to the number of load rollers on the abscissa. Then, multiply this factor by the elastic deformation value (on ordinates) which corresponds to the load (on abscissa) shown in Fig. III-2-6.

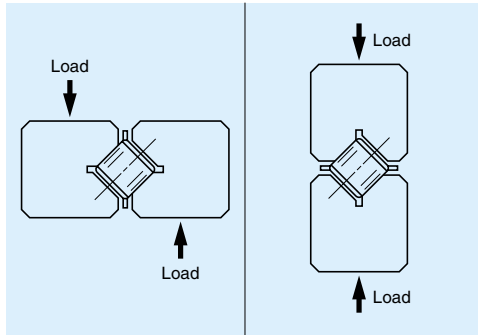

Fig. III-2-4

Fig. III-2-5

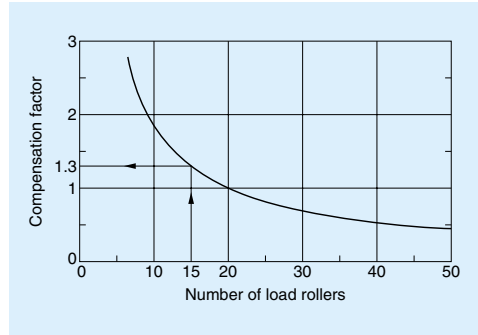

Fig. III-2-7 Compensation factor to obtain elastic deformation

[ Calculation example: Elastic deformation ]

A retainer which contains 30 rollers (roller diameter 6 mm) is installed on both right and left side (Fig. III-2.8). How large is the elastic deformation of the crossed roller guide when a load of 4kN is applied to the table center?

[Answer]

A load of 2kN is applied to each side of the crossed roller guide. The elastic deformation value on the ordinate which corresponds to the load 2kN on the abscissa (in Fig. III-2•6) is:

$$4.5\mu\text{ m}$$

This application of load is the same as in Fig. III-2•4. Therefore, the number of load rollers is one-half of 30, or 15. From Fig. III-2•7, the compensation factor on the ordinate which corresponds to 15 rollers on abscissa is:

$$1.3$$

Multiply 1.3 by 4.5  $\mu\text{ m}$  obtained above. The answer is:

$$4.5 \times 1.3 \doteq 6 \mu\text{ m}$$

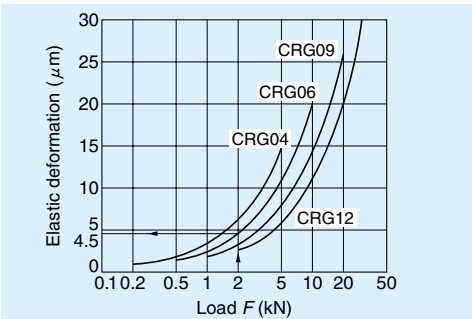

Fig. III-2-6 Elastic deformation with 20 rollers

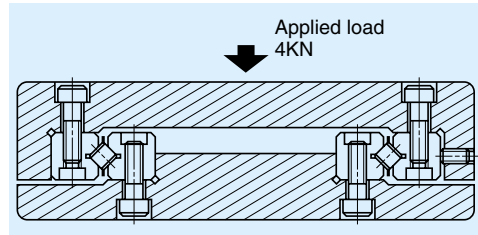

Fig. III-2-8 Example calculation of elastic deformation (illustration)

A-III-2.5 Friction Force

If installation and lubrication are appropriate, the starting friction coefficient is markedly small as shown below:

$$\mu = 0.005$$

A-III-2.6 Lengths of Rail and Retainer

The relationship of rail length L with stroke S is as follows:

$$\text{When } S \leq 400 \text{ mm, } L \geq 1.5S \dots\dots\dots(3)$$

$$\text{When } S > 400 \text{ mm, } L \geq S \dots\dots\dots(4)$$

Since the retainer travels a distance of half of the stroke, the retainer length K is:

$$K < L - \frac{S}{2} \dots\dots\dots(5)$$

The retainer does not detach from the rail when condition in Formula (5) is satisfied (Refer to Fig. III-2.9).

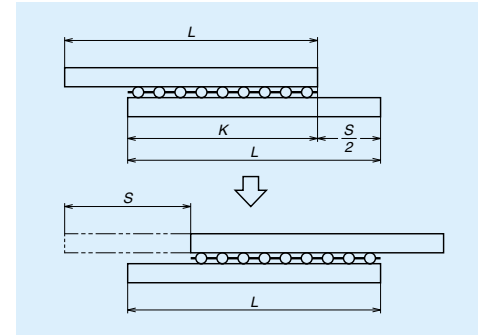

Fig. III-2-9 Relationship of rail and retainer

A-III-2.7 Lubrication and Dust Proof

For grease lubrication, lithium soap based greases of consistency 1 or 2 are used.

- For example; NSK Grease LR 3,
- NSK Grease PS 2,
- NSK Grease AS 2

For oil lubrication, JIS viscosity 32 to 150 is recommended.

When necessary, install a bellows on the rail, or install a seal on the side of the rail to arrest foreign matters and dust as shown in Fig. III-2•10.

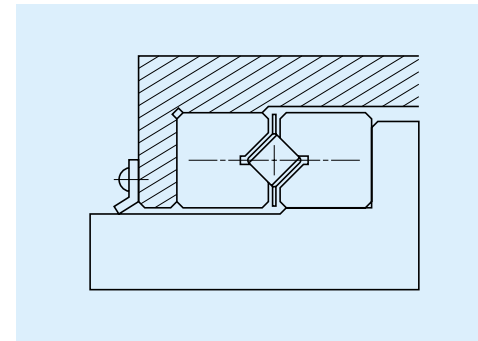

Fig. III-2-10 Dust prevention (example)

A-III-2.8 Installation

Fig. III-2•11 shows the standard installation procedures.

- ① Secure Rail 1 and 2 to the bed using the fixing bolts. Secure Rail 3 to the table with the bolts. Temporarily secure Rail 4 and loosen the side bolt.
- ② Match the bed and the table. Insert the retainer in the roller space. At this time, measure the distance from the rail end to the retainer end with a depth gauge to determine its position. If the roller space is too narrow and the retainer does not go inside, slide Rail 4 toward the side bolt, then insert the retainer.
- ③ Follow the reading of dial gauge which is previously set, and squeeze in all side bolts until they stop rattling. Do not apply excessive force. When the side bolts are tightened, the rollers should be in the vicinity of the bolt position. Then, secure Rail 4 with the fixing bolts. Finally, install a stopper to the rail end.

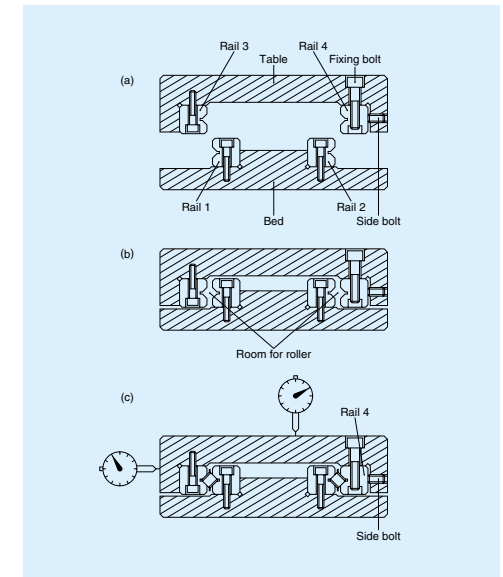
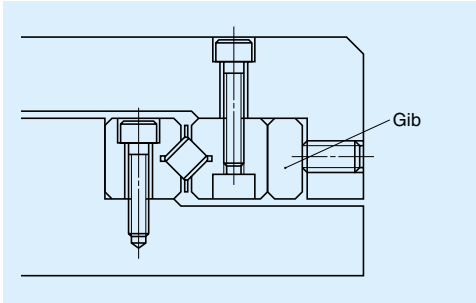

Fig. III-2-11 Standard installation procedures

**[Regarding preload]**

As crossed roller guide has higher rigidity than other linear rolling guides, it does not need preload. It is also difficult to apply preload accurately. Crossed roller guide is usually used without clearance. For highly accurate applications, it is desirable to press the crossed roller guide by means of a bolt over the gib as shown in Fig. III-2-12.



**Fig. III-2-12 Tightening using a gib**

Therefore,  $C_{15}$  is obtained from the following formula. Rated life (km) is shown in the formula below. In this formula:

$$L = 5 \times 10^6 \left( \frac{C_{0n}}{f_w \cdot F_c} \right)^{\frac{10}{3}} \dots \dots \dots (7)$$

$f_w$ : Load factor. 1.0 ~ 1.2 under smooth operation

$F_c$ : Computed load which applies to the guide (kN)

Please refer to NSK Linear Guide Technical Description for details.

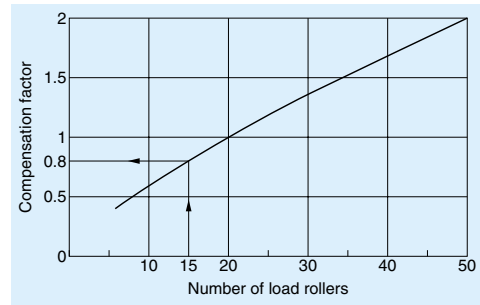

**Fig. III-2-13 Compensation factor for basic dynamic load rating**

**A-III-2.9 Basic Static Load Rating**

Basic static load rating becomes larger in proportion to the number of the load rollers "n." Obtain basic static load rating per roller  $C_{01}$ . Then the basic static load rating  $C_{0n}$  when the numbers of rollers is n can be obtained as follows.

$$C_{0n} = n \times C_{01} \dots \dots \dots (6)$$

Values of  $C_{01}$  are shown in the dimension table.

**A-III-2.10 Basic Dynamic Load Rating and Rated Life**

Basic static load rating is based on a rated traveled distance of 50 km. The dimension table shows the value with 20 load rollers. When the number of load rollers is other than 20, a basic dynamic load rating  $C_r$  can be obtained by multiplying a compensation factor (obtained from Fig. III-2-13.) by C in the dimension table.

(Suffix 'n' is to refer the number of load rollers.)

As an example; Number of load rollers:  $n = 15$ .

The compensation factor from Fig. III-2-13 is 0.8.

$$C_{15} = 0.8 \times C$$

**A-III-2.11 Reference Number and Standard Set for "One-Axis"**

Specifications are indicated as a reference number as shown below.

<b>CRG06-380 A P5 N</b>			
Model number		Holes for mounting	Tap hole: N Drill hole: D
Rail length (mm)		Accuracy grade	P5...Super precision grade P6...High precision grade
Shape of the rail cross section	Standard: A    Semi-standard: T		

**Note (1)** : Semi-standard T, a shape of rail cross section, is available only for CRG04. It is lower in H dimension, and wider in W dimension compared with A.

**Remarks** : Standard set for "one axis" of the guide refers to 4 rails and 2 retainers which usually comprise the guide way for a one axis.

A-III-2.12 Dimension Table

Crossed roller guide: Model CRG

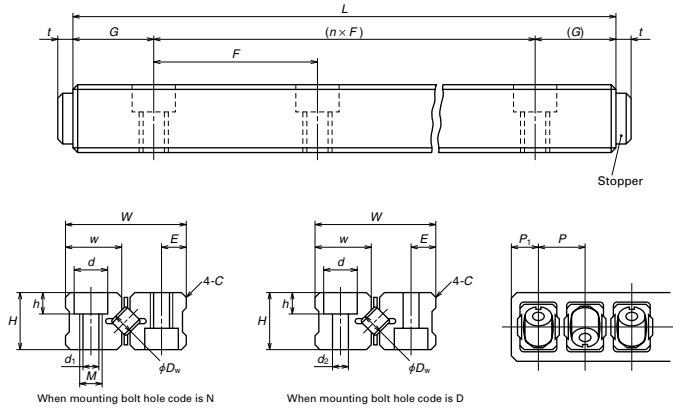

Unit: mm

Model No.	$D_w$	$W$	$H$	$w$	$C$	$E$	$d$	$h$	$d_1$	$d_2$	$M$	$G$	$F$	$t$	$P$	$P_1$	Dynamic load rating $C$ when rollers are 20 (N)	Static load rating $C_0$ when roller is one (N)	$L$ Max length	High precision P5	Super high precision P6
CRG04...A	4	24	12	11.3	0.5	5	8	4.2	4.3	5	M 5x0.8	20	40	2.3	6.5	3.8	9800	665	200	300	
CRG04...T	4	26	10	12.3	0.5	5	8	4.2	4.3	5	M 5x0.8	12/15	38/40	2.3	6.5	3.8	9800	665	200	300	
CRG06...A	6	31	15	14.5	0.8	6	9.5	5.2	5.2	5.5	M 6x1	25	50	3.2	9.5	5.8	26700	1510	400	600	
CRG09...A	9	44	22	20.7	1	9	11	6.2	6.8	7	M 8x1.25	50	100	4	14	8	72500	3400	600	900	
CRG12...A	12	58	28	27.6	1.5	12	14	8.2	8.5	9	M 10x1.5	50	100	5	20	12	130000	6050	900	1200	

Remarks: The area which embraces the roller is plastic for the standard retainer. A solid type made of steel plate is available for high temperature resistance.

A-III-3 Roller Pack

A-III-3.1 Structure

A roller pack comprises a main body which supports load from the guide way block via two rows of rollers; an end cap which change the direction of the recirculation of rollers at the end of the main body; a side plate which guides the rollers. (Fig. III-3-1). Roller pack is one of linear rolling guide of which rollers are allowed to re-circulate infinitely for free from restriction of running range (stroke).

There is a plate spring attached to a side of roller pack to prevent roller pack from falling out when it is turned upside down after assembly.

Other component of the roller pack is spring pin. Spring pin is on the top surface of the roller pack, and makes installation of wedge block and fitting plate easier.

Wedge block is a unit to provide preload (Fig. III-3-3) to roller pack; a fitting plate (Fig. III-3-2), functioning like a pivot, adjusts misalignment of roller pack automatically. Wedge of wedge block moves up and

down, to apply preload, by turning the adjust screw.



Photo 1 Roller pack



Photo 2 Wedge block

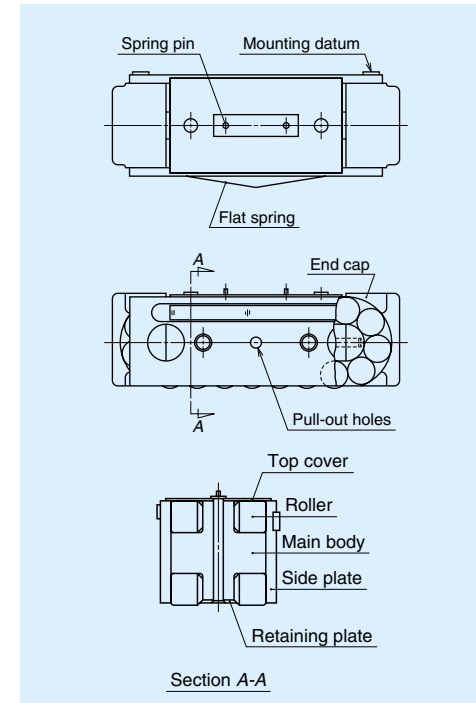

Fig. III-3-1 Roller pack

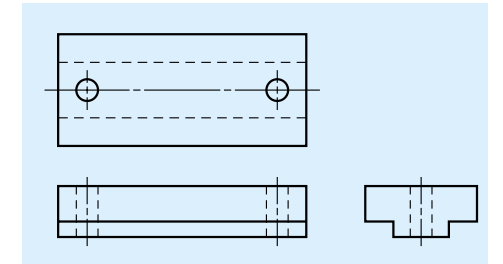

Fig. III-3-2 Fitting plate

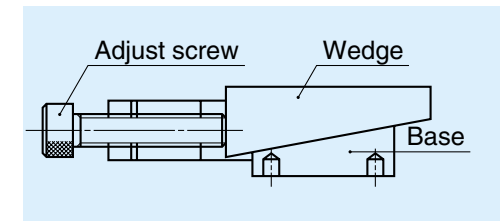

Fig. III-3-3 Wedge block