

B-2-11 Rust Prevention and Surface Treatment of Ball Screws

(1) Stainless steel ball screw

Stainless products KA is standard ball screw and available in stock. Please consult NSK if you require custom made stainless steel ball screw.

(2) Types of surface treatment

The following are common types of treatment.

- Low temperature chrome plating
 - Used to prevent corrosion and light reflection, and for cosmetic purpose.
- Fluoride low temperature chrome plating
 - Fluoroplastic coating is provided following the low temperature chrome plating.
 - Resistance to corrosion is higher than low temperature chrome plating.
- Hard chrome plating
 - Has high hardness. Increases resistance to both wear and corrosion.
- Electroless nickel plating
 - Creates a film of consistent thickness on complex shaped items.
 - For corrosion prevention.

(3) Recommended surface treatment

Among the surface treatments mentioned above, we recommend "Low temperature chrome plating" and "fluoride low temperature chrome plating" for rust prevention because of the result of humidity chamber test for antirust characteristics.

However, never apply any organic solvent for degreasing because it has adverse effect on antirust characteristics.

Table 11.1 Surface treatment length

	Applicable length
Low temperature chrome plating	5 m or less
Fluoride low temperature chrome plating	4 m or less

Refer to 1.3 "Rust Prevention and Surface Treatment" (Page D5) for the results of humidity chamber test.

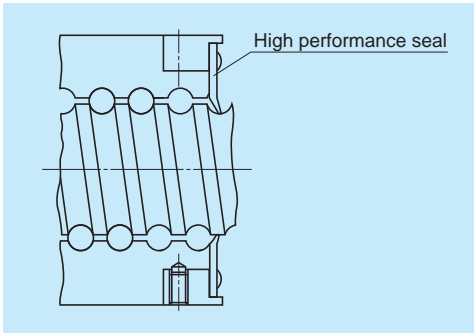

Fig. 10.5 High performance seal

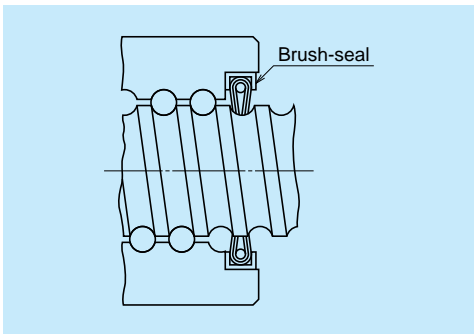

Fig. 10.6 Brush-seal for R Series

B-2-12 Ball Screw Specifications for Special Environment

B-2-12.1 Clean Environment

NSK manufactures NSK Clean Grease "LG2 and LGU" for NSK linear guides, ball screws, and Monocarriers which are used under normal temperature and pressure in a clean room.

LG2 and LGU grease are far more superior in stable torque characteristics than the vacuum grease which has been used as a countermeasure against dust generation. LG2 and LGU also have a sufficient durability and dust prevention capability.

Features of "LG2 and LGU"

- ① Generates less dust than vacuum grease and other general greases. Cleanliness is enhanced by simply switching the grease to LG2 or LGU.
- ② Has extremely low and stable torque characteristics. It is ideal for high speeds.
- ③ Unlike vacuum grease, LG2 and LGU have a nature similar to general grease. Its effect is long-lasting, and sufficiently durable. They greatly contribute to minimize the frequency of maintenance.
- ④ They have an equal capability in rust prevention as general grease, and also is reliable.

When using NSK linear guides, ball screws, or Monocarriers in a clean environment, request LG2 or LGU as a packed lubricant prior to delivery. NSK also makes bellows-tubes which contain 80 grams of LG2 or LGU. The tube is easy to use, and is ideal for maintenance. (Refer to Pages B455 and D20). Wash to remove adipose substances prior to use.

Refer to Page D8 for detailed nature, functions and characteristics of LG2 and LGU.

B-2-12.2 Measures for Use under Vacuum

NSK developed MoS₂ / WS₂ spattering and dry-filmed ball screws for equipment to be used in space. NSK also makes soft-metal film (gold and silver) ball screws to be used in a vacuum environment for semiconductor and liquid crystal display processing equipment.

Lubricants widely used for ball screws in a high vacuum are:

- Vacuum grease which uses base oil of low vapor pressure.
- Solid lubricants such as MoS₂, WS₂ used mainly for equipment in space.
- Solid lubricants by soft-metal such as gold, silver, or lead film.

When used for semiconductor and liquid crystal display making equipment, the oil of the vacuum grease evaporates and causes environmental contamination. Also, it hinders creation of a super high vacuum. MoS₂ in the state of solid lubricant generates a large volume of dust, and Mo is unsuitable for semiconductors and reformed surface. Therefore, it is not suitable for the processing machines for semiconductor and liquid crystal display.

NSK recommends solid lubricant ball screws with a long life. These ball screws are treated with special silver film by NSK's unique processing technology, and can be used in a super-high vacuum. However, because of a solid lubricant, the film may peel off and stick to surface of ball grooves repeatedly, causing the torque to rise momentarily on some occasions. The drive motor should be of large capacity to handle this drastic variation of torque.

Refer to Page D7 for test data of ball screws for vacuum.

For ball screw specifications for special environment, refer to Page D2.