

NSK TF TOUGH STEEL™ FOR HARSH WORKING CONDITIONS

Controlling Bearing Failure in Contaminated Environments

NSK's concept of long life in contaminated environments is unique in the bearing industry. NSK's research has enabled it to be the first to recognize the relationship between the retained austenite and rolling fatigue life in contaminated environments.

Bearings in clean environments operate under very clean grease or highly-filtered oil lubrication and will eventually fail due to subsurface origin-type fatigue if installed properly. Bearings subjected to a contaminated environment fail due to surface origin-type fatigue. Cleaner steel has been proven to be effective in promoting the longer life of bearings operating in clean environments while "sealed and clean" bearings are effective in promoting longer bearing life under contaminated conditions.

Debris in bearings is prevalent in the mining, aggregate, steel, and cement industries. This debris generates surface origin fatigue and causes shorter bearing life. Sealed and clean bearings use a contact seal to exclude harmful debris from entering the bearing. Unfortunately, sealed bearings are not feasible in every application or the seals don't always keep out all the debris. Tough Steel™ bearings are needed in those applications.



The Process of Surface Originating Flaking

Various types of debris can generate indentations in the raceways of rotating bearings. Contact stress is extremely high at the indentation edges and fatigue damage occurs at an accelerated rate (Fig. 1).

FIGURE 1 | Origin of Surface Originated Flaking

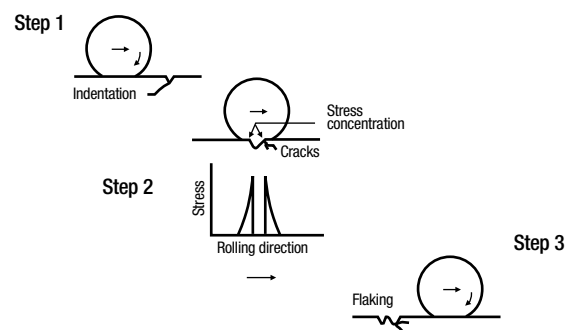

The Process of Surface Originating Flaking

The following equation describes the stress concentration at the shoulder of an indentation². The ratio of maximum shear stress t_c at the indentation to the nominal contact pressure, p_o , in the case of no indentations is as follows:

$$t_c / p_o = a_1 (Co)a^2$$

Where, $a_1 = 0.22$
and $a^2 = -0.24$

Co is called the furrow severity factor and is found by using the following equation.

$$Co = (\pi 2 p_o / E^o) (r/c)$$

r = radius of furrow shoulder, mm
 c = half value of furrow width, mm
 p_o = nominal contact pressure, N/mm²
 E^o = reduced Young's Modulus, N/mm²

In the above equation, the shape of the indentation, in terms of r and c (Fig. 2), applies a strong influence on the fatigue life of the bearing. A higher r/c value promotes longer bearing life because of the lower stress concentration at the edge of the indentation.

FIGURE 2 | Enlarged View of Indentation Caused by Contamination

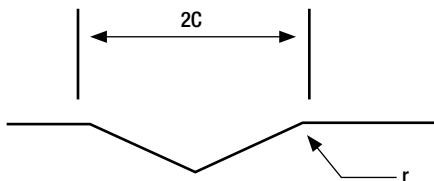

Indentation Contour and Material Factor

The following experiments were performed in order to clarify the relationship between indentation contour (ratio of r/c) and the percentage of retained austenite. This was done in a thrust bearing test machine used for evaluation of rolling-contact fatigue life. The spindle section of the thrust bearing test machine with the test specimen is shown in Fig. 3.

Test Procedure

1. Washer-type test pieces, which had a wide range of hardness and retained austenite, were prepared from an assortment of material and heat treatment processes.
2. A Vickers indentation was made on each test race.
3. r and c values created by the indentation were measured.
4. Each test race was set in the test machine and submerged in a clean oil bath. Stress was applied by rolling steel balls over the indentation with a specified load.
5. The indentation contour was traced after removing the test piece from the test machine.

FIGURE 3 | Spindle Section of the Thrust Bearing Test Machine

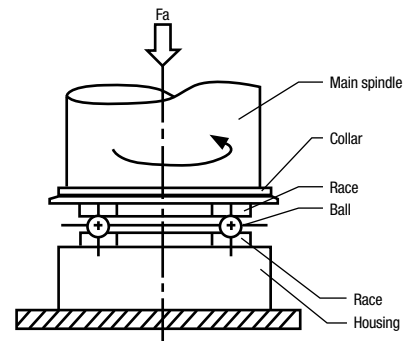

Analysis of r/c versus cycles on the above test showed r/c to stabilize after 3,000 cycles. Results from the above test show that after one minute (3,000 cycles) of testing, the value of r/c goes up with increased volume percentages of the retained austenite. The upper limit of retained austenite is governed by the dimensional stability and is mentioned later in this paper.

The test was next done with three different sets of samples. Set ONE had samples containing 32% retained austenite and a hardness value of Hv802. Set TWO had samples containing 33% retained austenite and a hardness value of Hv716. Set THREE had samples containing 10% retained austenite and a hardness value of Hv739. By comparing set ONE with sets TWO and THREE, it was revealed that repeated stress produced a higher r/c value in harder materials than in softer materials. It was also noted that the stress relaxation for the softer material with a lower austenite level is almost completed within a relatively short time of a few thousand cycles. The harder material and higher austenite level continued in stress relaxation due to the r/c value continuing to increase.

New Material Requirements

Since retained austenite itself is soft, it is difficult to produce a part with both high hardness and high volume of retained austenite. Therefore, new steel specifications were required. Innovative heat treatment processes were created to overcome the special requirements in the steel. This was done by increasing the chromium content of the steel, resulting in a greater number of fine carbides or carbo-nitrides distributed within the material matrix.

Conventional heat treatment processes cannot attain the required material properties. Conventional is identified as being carburized or through hardened bearings, since the life results are similar in a contaminated environment. New heat treatment processes were developed to refine the carbides or carbo-nitrides after carburizing or carbo-nitriding.

Based on the results of this study, new Tough Steel™ specifications were formulated. These specifications include the following elemental content:

C	Si	Mn	Cr
0.42%	0.39%	1.24%	1.23%

Fatigue Life Testing

Another thrust bearing test was performed under conditions of contaminated lubrication. The results indicate a controlled increase in the volume of retained austenite leads to a longer life. Furthermore, if the volume of retained austenite is maintained but the hardness is increased, an even longer life is attainable.

To again prove the required material parameters, actual bearings were made from such materials and tested with contaminated lubrication. The test rig used for this evaluation is shown in Fig. 4.

The bearings in this test were run in contaminated gear oil. The contamination was mixed thoroughly with the oil allowing the mixture to pass through the test bearing. The oil temperature was controlled to maintain the viscosity. Tough Steel™ bearings ran successfully for a life that was 7 to 11 times longer than the conventional carburized or through hardened taper bearings.

The life test results of deep groove ball bearings show Tough Steel™ bearings have 6 times more life than conventional ball bearings.

Fatigue Progression

To analyze the longer life of Tough Steel™ bearings, the following tests were performed using the medium box test machine. During these life tests, the fatigue progress in the raceway surface was measured after a certain interval using “Fatigue Analysis”. This “Fatigue Analysis” is an original method developed by NSK.

Using X-ray diffraction technology, NSK determined fatigue progress in the material in a semi-quantitative manner. As fatigue progresses, a change occurs in the martensite crystal lattice and retained austenite converts into martensite. Measuring both factors by X-ray, it is possible to determine the type of fatigue (surface origin or subsurface origin) and the stage in the fatigue progress. Either destructive or non-destructive inspection can be performed in “Fatigue Analysis”.

After a certain interval in each test, a non-destructive inspection was made. This inspection used X-rays on the rolling contact surface only and evaluated the changes in the material structure.

After the life test, a destructive inspection was made by using X-ray analysis. This requires the removal of very thin layers of the bearing material at the indentation zone and recording the material structure changes within the bearing. This investigation revealed that under the same loading and environmental conditions, Tough Steel™ bearings exhibit a slower progression of fatigue than conventional bearings.

The test started with a model indentation and was run until flaking occurred in the bearing raceway. This was done by pressing a Vickers indenter into the surface. Then the contour of the indentation was measured.

FIGURE 4 | Test Rig for Bearings Using Contaminated Lubrication

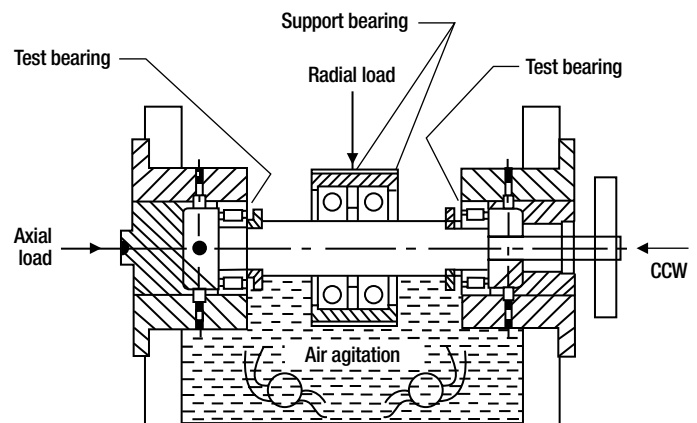

Next, the bearing was loaded and a life test was performed with clean lubrication. At a certain interval, the bearings were removed from the medium box tester. The surface was observed with a microscope and the contour of the indentation was measured. This process was repeated until flaking occurred.

NSK then noted the starting point of the crack and the flaking area in both Tough Steel™ and conventional bearings. The Tough Steel™ bearing's crack was delayed in appearing and the progression to flaking had been slowed.

Test results reveal that Tough Steel™ bearings have a larger shoulder radius at the indentations than that of conventional bearings. The results have shown that Tough Steel™ bearings have longer life under contaminated conditions, since there is a lower stress concentration at the shoulder of the indentation. This difference in radius shape is the reason for the Tough Steel™ bearing having longer life in contaminated environments.

Wear Resistance and Seizure Limit

Tough Steel™ bearings have a large number of fine carbides and carbo-nitrides that give a higher resistance to wear and greater seizure resistance. The test results of the wear-amount rate and seizure limit were determined by a Sawin-type test machine which is specifically used to evaluate wear resistance. The results show that the bearings with Tough Steel™ material had less wear and a higher seizure limit than conventional, through hardened and case hardened materials. Even though the load used seems small, the maximum surface contact pressure is 98 N/mm². The Sawin-type test machine was used because it can also simulate a “no lubrication” condition. This is valuable in helping to identify the change point from mild wear to severe wear which is recognized as the seizure limit.

Dimensional Stability

Another important characteristic of a bearing material is dimensional stability. Several tapered roller bearings were tested using Tough Steel™, through hardened, and case-hardened materials. The outside diameter of the L44610 bearing used for this test is 50.292 mm.

Samples of five types of materials were kept in an oven at 130°C for 4,000 hours and then the outside diameters of the bearings were measured. Another set of samples of five types of materials were kept in an oven at 170°C for 1,000 hours. The outside diameters of the bearings were then measured. The Tough Steel™ dimensional stability is between that of through hardened and case-hardened bearings.

The results of case-hardened bearings, carburized and carbo-nitriding, were also plotted in comparison to the Tough Steel™ bearing. The carburized bearing showed similar results with the Tough Steel™ bearing but the carbo-nitriding bearing showed very large expansion of the outer ring in both temperature ranges.

Conclusion

1. For bearings in applications with contaminated lubrication, such as seen in mining, aggregate, cement and steel mills, a material with a high volume of retained austenite and a high hardness provides longer life.
2. To attain such properties new steel specifications and tightly controlled heat treatments were developed and implemented to produce Tough Steel™ material.
3. Tough Steel™ bearings have more than 6 times longer life over conventional bearings under similar contamination and loading conditions.
4. Tough Steel™ bearings have a slower rate of fatigue progress. Crack initiation is delayed, and crack propagation is slower at the shoulder of the indentation.
5. Tough Steel™ bearings have 8 times more life than that of conventional bearings when compared in an actual life test.
6. Tough Steel™ bearings provide advantages in both wear resistance and seizure limit.
7. Dimensional stability is between that of through hardened and case-hardened materials.

1. Murakami, Y. and Matsumoto, Y. “Study of Long Life Bearing Materials” Preprints of JAST Tribology Conference, Okayama, (1988) 297 - 300. [in Japanese]
2. Chiu, Y.P. and Liu, J.Y. “An Analytical Study of the Stress Concentration Around a Furrow Shaped Surface Perfect in Rolling Contact,” Trans. ASME, JOLT, (1970) 258-263.
3. Tanaka, E., Furumura, K, and Ohkuma, T. “Highly Extended Life of Transmission Bearings of Sealed-Clean Concept,” SAE Paper 830570 (1983).
4. Yasuo Murakami and Takaaki Shiratani “Fighting Debris: Increasing Life with HTF Bearings for Transmissions,” SAE Paper No. 940728 (1984)

➔ For more information, please contact NSK at 1.88ThinkNSK (1.888.446.5675) or visit www.nskamericas.com