

## TL SERIES SPHERICAL ROLLER BEARINGS

### TOUGH AND LONG-LIFE PERFORMANCE IN PAPERMAKING MACHINES

High speeds. Moisture. Intense heat. The forces at work on the bearings used throughout papermaking machines are extreme. And the stakes are high.

With throughput as great as thousands of feet per minute, a single bearing failure can bring the paper that flies across a machine's network of rolls to an abrupt halt. At a significant cost.

TL - Tough & Long-Life - spherical roller bearings are engineered to outlast and outperform conventional bearings in the high heat of dryer and calender applications of papermaking machines, where inner ring fracture and bearing failures due to hoop stress can impede productivity.



#### PROVEN OPERATING ADVANTAGES

- ➔ More than twice the service life of conventional bearings when operating under contaminated conditions
- ➔ High-strength resistance to hoop stress and inner ring cracking
- ➔ High raceway surface hardness for a long wear-resistant service life
- ➔ Dramatically reduced bearing failures for optimized machine uptime with reduced maintenance costs

## FAILURE MECHANISM IN PAPER MACHINE DRYER ROLLS

On a paper or board machine, the drying process occurs when heat is transferred from the dryer roll to the sheet contacting the roll. The source of this heat is steam, passing through the hollow axis of the roll. Increasingly higher steam temperatures can contribute to higher drying speed and improved machine efficiency, but not without presenting a significant challenge to the bearings that are essential to smooth and trouble-free operation.

On machine start-up in particular, high steam temperature causes the journal to expand more rapidly than the bearing. This increases the tightness of fit between the mating surfaces and causes hoop stress (circumferential force) in the bearing inner ring. As this thermal stress increases, so too does the risk of crack formation and the inevitability of inner ring fracture.

Conventional measures such as adopting a slow start-up procedure can prevent such problems – by introducing temperature gradually - but can consume several hours and compromise production. And other approaches to product solutions exist, but with compromised success.

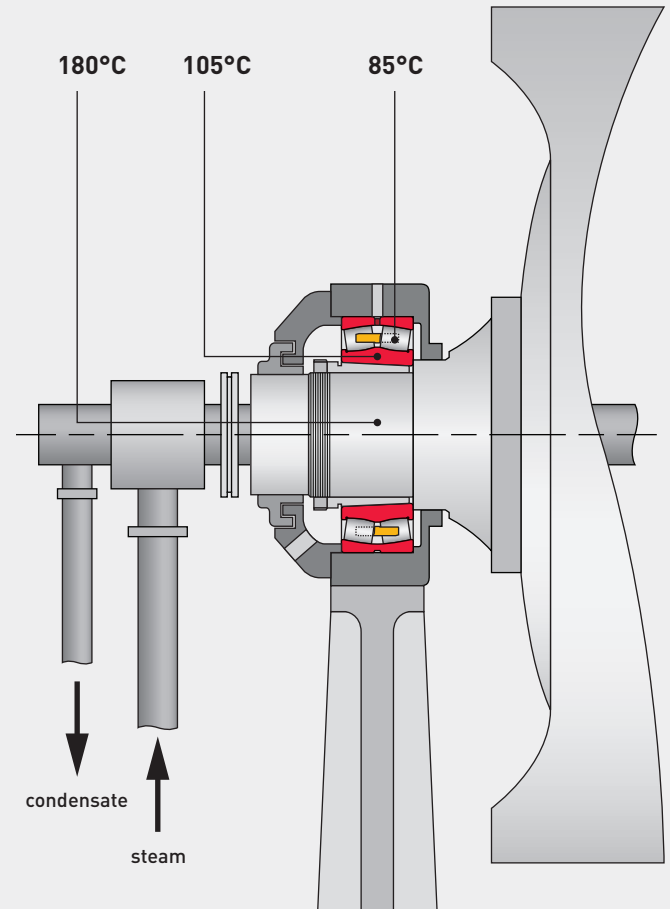

### Illustrated at top:

Example of a dryer cylinder roll structure showing the typical temperatures present

### At bottom right:

The journal expands faster than the bearing inner ring, creating an extremely tight shaft fit and causing severe hoop stress

### At bottom left:

The inner ring of a damaged spherical roller bearing with axial cracks on the raceway surface

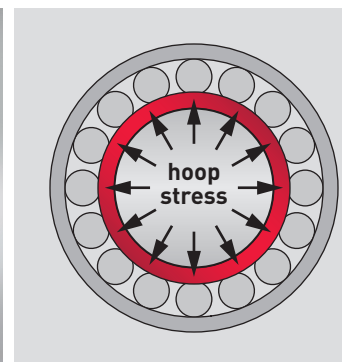

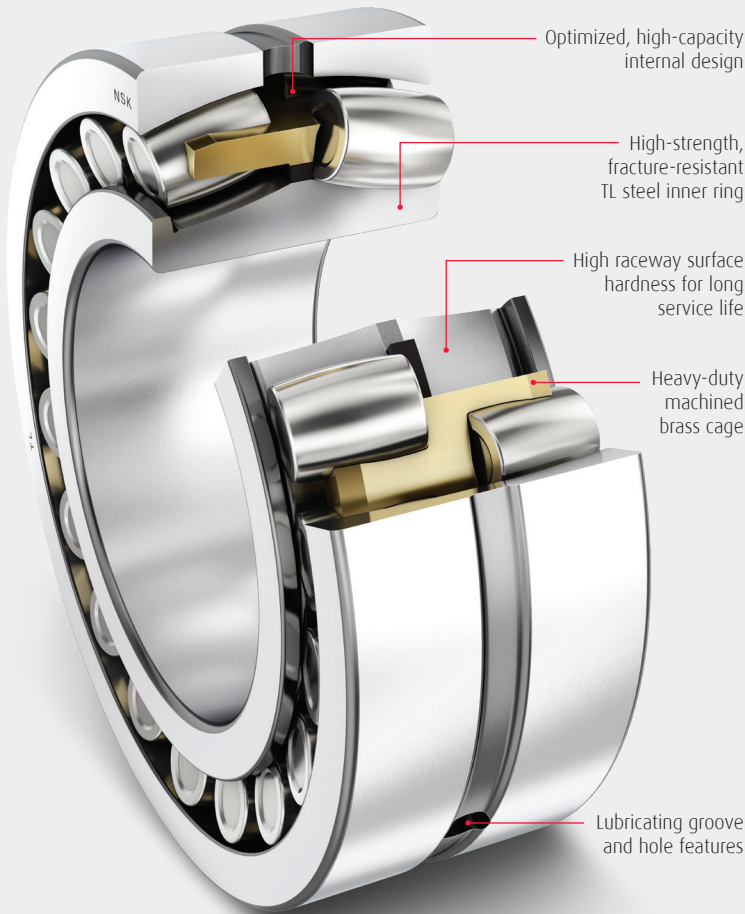

## TL SERIES ROLLER BEARINGS EXTEND BEARING LIFE

THROUGH THE UTILIZATION OF LEADING-EDGE MATERIAL AND HEAT TREATMENT TECHNOLOGIES

NSK has developed a proprietary material composition containing appropriate levels of chrome to promote increased hardness. Coupled with an advanced carbonitriding heat treatment process, the result is a case-hardened inner ring that delivers considerable performance advantages:

- ➔ Exceptional ring fracture resistance derived from high compressive residual stress after heat treatment
- ➔ Long-life wear resistance due to superior surface hardness values, exceeding conventional through-hardened and carburized materials
- ➔ High dimensional stability at operating temperatures up to 200° C

<b>Problem:</b> premature bearing failure	➔	<b>Countermeasure:</b> advanced material composition	➔	<b>Countermeasure:</b> heat treatment technology	➔	<b>Solution:</b> tough and long-life TL steel
› inner ring fracture occurring due to repetitive hoop stress		› optimized material composition for increased hardness		› carbonitriding for high compressive strength		› fracture and wear resistant with high dimensional stability



## CASE STUDY

### APPLICATION

## PAPER MACHINE DRYER CYLINDER

### COST SAVINGS

**\$226,330 / YR FOR 10+ YEARS**

A paper mill requested that NSK review the relentlessly poor performance of the drive side bearings on dryer cylinders, requiring replacement as frequently as 3 to 4 times annually.

Proven success was replicated for, and by, this customer: NSK's TL bearing solution has been in operation for more than 10 years and has been adopted by the mill plantwide to perpetuate additional savings with:

- ➔ **Reduced bearing consumption** and associated replacement costs
- ➔ **Reduced maintenance intervals and costs** incurred with bearing replacement
- ➔ **Reduced production losses** incurred as a result of machine maintenance downtime



[DOWNLOAD THE COMPLETE CASE STUDY ▶](#)

## YOUR PARTNER FOR MACHINE OPTIMIZATION

Our AIP Added Value Program is based around a simple proposition: 'improvement pays'. By working with you throughout the AIP Value Cycle, we will help you achieve improvements in machine reliability, productivity and performance, all of which carry a tangible and measurable cost benefit – and we have the tools to prove it! That's what we mean by **improvement pays**.



NSK's TL series spherical roller bearings are ideally designed to deliver Tough and Long-Life performance wherever elevated temperatures prevail in the papermaking process - in dryer rolls, canvas rolls, PV rolls and calender rolls.

When total machine efficiency and output hangs in the balance, NSK TL spherical roller bearings provide an advanced solution with a predictably reliable outcome.

- ➔ **Higher fracture resistance** with inner ring strength to increasing hoop stress caused by shaft temperature rise
- ➔ **Longer fatigue life** achieved with increased raceway surface hardness, even when foreign debris is present
- ➔ **Dimensional stability** at high temperatures - up to 200°C - equivalent to, or greater than, traditional stabilizing approaches
- ➔ **An extensive range** of dimension series and sizes - for bore diameters up to 1,000 millimeters

Learn more about NSK bearing products and services for optimizing machine performance in the papermaking industry. Follow us at:

[www.nskamericas.com](http://www.nskamericas.com)



CONTACT NSK ▶

